

HiTECH

Technologies, Inc.

NIVOCONT Bulk Solids Point Level

Vibrating Rod Sensing Technology

Model RKN-302

**“SELF-CLEANING” probe
delivers unprecedented performance**

IDEAL for

- ◆ Plastics - *powders, pellets*
- ◆ Pulp & Paper - *cellulose, wood chips*
- ◆ Power - *fly ash, lime, carbon black*
- ◆ Foods - *cereals, grains, flour*
- ◆ Mining - *coal, sand, clay, cement*
- ◆ Chemicals - *crystals, pills, powders*



ADVANTAGES

Economical - Low Cost

“Self-Cleaning” Sensor

Easy to Install & Set-up

Rugged - Maintenance-free

Fine Polished Stainless Steel Probe

Dust “Ex” approved

The **NIVOCONT RKN-302** is the IDEAL level switch for use in silos or bins containing free-flowing powders or granular materials such as carbon black, sugar, grain, flour, cement, lime, sand, etc. (minimum material bulk density of 3 lbs./ft³ .

The unit is extremely easy to install, requiring only a 1½” NPT female socket in either the top or side of the vessel. The NIVOCONT is approved for use in dust hazardous areas (Zone 10).

The vibrating rod is a mechanical resonant system piezo-electrically energized, maintained in resonance by the electronic circuitry.

When the material contacts the rod, the vibration is dampened, this is detected by the electronics which, after a brief time delay, switches the output relay.



HiTECH Technologies, Inc.

301 Oxford Valley Road, Yardley, PA 19067-7706

Technical support: 800. 755. 4507

Tel: 215. 321. 6012 ~ Fax: 215. 321. 6067 ~ www.hitechtech.com

HiTECH

Technologies, Inc.

NIVOCONT **Bulk Solids Point Level**

Model RKN-302

SPECIFICATIONS

Type Vibrating Rod Technology with "SELF-CLEANING" sensor	Output Relay SPDT - 8 amp, 250 VAC	Sensor 316 Stainless Steel Ti Fine Polished
Material Density > 0.3lb/cu-ft	Output Time Delay 6 seconds (fast response available)	Probe Length 9-1/4 " standard
Temperature Medium -40 to +320 °F	Supply 230, 110, 24 VAC 50/60 HZ 24 VDC (reverse polarity protected)	Housing Cast Aluminum Stove Enameled
Pressure Up to 368 psi	Ex Certificate Dust Ex Zone 10	Mounting 1½" NPT

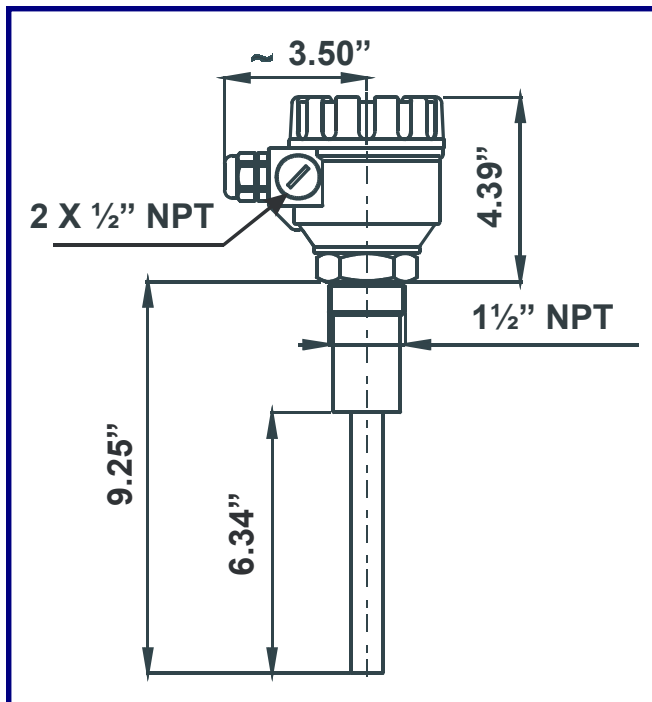

PERFORMANCE GUARANTEE

Since 1986, every instrument sold by **HiTECH** has been guaranteed to perform in the application it originally was engineered and recommended for. Our company policy remains the same, every product sold comes with a **written performance guarantee**.

Should the equipment be unable to perform satisfactorily in your application and we are not able to correct the problem, we will accept the instrument in return and issue full credit.

This performance guarantee is valid for 60 days. Thereafter, our standard limited two years factory warranty goes into effect.

Copyright HiTECH Technologies, Inc. 2002

HiTECH Technologies, Inc.

301 Oxford Valley Road, Yardley, PA 19067-7706

Technical support: 800. 755. 4507

Tel: 215. 321. 6012 Fax: 215. 321. 6067 www.hitechtech.com