

**NIVOCAP Cxx-200 SERIES  
CAPACITANCE TWO-WIRE  
LEVEL TRANSMITTER**



***HiTECH* Technologies, Inc.**

---

301 Oxford Valley Road - Building 505A - Yardley, PA 19067-7706

Tel: 215. 321. 6012; Fax: 215. 321. 6067

Tech Support (Toll Free) 866-DrLevel or 888-NIVELCO

Email: [info@DrLevel.com](mailto:info@DrLevel.com) or [info@hitechtech.com](mailto:info@hitechtech.com)

Web Site: [www.DrLevel.com](http://www.DrLevel.com) or [www.hitechtech.com](http://www.hitechtech.com)

# 1. APPLICATION

NIVOCAP □□□-□□□□-□ series level transmitter operating on the capacitance principle can be used for level measurement of conductive or nonconductive liquids or free flowing solids both in ordinary and hazardous environments. The active probe of the unit and the conductive wall of the vessel make up the plates of a capacitor. If the tank is nonconductive a reference probe should be applied. The change in the current flowing through this capacitor, generated by the measuring voltage is proportional to the change of the material's level between the electrodes.

# 2. TECHNICAL DATA

| Type   |                    | Rod probe  | Cable probes  | Heavy duty cable probes               |
|--|--------------------|--|---|---------------------------------------|
| Range  |                    | 0.2 ... 3 m  | 1 ... 20 m  |                                       |
| Material of wetted parts                               | Process connection | Stainless steel (DIN 1.4571)   |   |                                       |
|  | Probe              | Partly or fully PFA coated steel<br>St. St. DIN 1.4301   | Partly or fully FEP coated steel cable  | Partly or fully PE coated steel cable |
| Housing material                                       |                    | Aluminum casting or plastic (VALOX412)   |   |                                       |
| Medium temperature*                                    |                    | -30 °C... +200 °C  |   | -25 °C ... +80 °C                     |
| Medium pressure  |                    | Max. 6 MPa (60 bar) +20°C (See pressure diagram)   |   | Max 1.6 Mpa (16 bar)                  |
| Ambient temperature*                                   |                    | -25 °C ... +70 °C  |   |                                       |
| Mechanical strength                                    |                    | -  | 7.7 kN  | 45 kN                                 |
| Saturation capacitance of the coated probe             |                    | -600 pF/m  | ~200 pF/m   | ~600 pF/m                             |
| Output   |                    | 4 ... 20 mA, two wire (3,9 ... 20,5)   |   |                                       |
| Voltage output for checking output current             |                    | Voltage measurement on a serial resistor: 1 mV / 1 mA  |   |                                       |
| Digital communication                                  |                    | HART**   |   |                                       |
| Display  |                    | SAP-202**  |   |                                       |
| Measurement range                                      |                    | 0 pF ... 5 nF  |   |                                       |
| Minimum transmittance range of capacitance (min. SPAN) |                    | 10 pF, or 10%  |   |                                       |
| Damping  |                    | 3, 10 or 60s   |   |                                       |
| Fault indication                                       |                    | By blinking of the COM and the VALID LEDs and by change of the output current to 3.8 or to 22 mA (selectable)  |   |                                       |
| Transmitter voltage/power supply                       |                    | 12 ... 36 V DC max. 22 mA / 48 ... 800 mW  |   |                                       |
| Load resistance (max.)                                 |                    | $R_{lmax} = \frac{U_l - 12V}{0.02A}$   | Where $U_l$ is the supply voltage.<br>(For HART interface $R_{lmin}$ , 250 ohm) |                                       |
| Accuracy   |                    | ± 0.3 %  |   |                                       |
| Temperature coefficient                                |                    | ± 0.02% / °C   |   |                                       |
| Electrical connection                                  |                    | Pg 16 or M20 x 1,5 for cables Ø 8...Ø 15 mm, or Ø 6 ... 12 mm, in Ex version for cables Ø 9,5...Ø 10 mm wire cross section 0.5 ... 1.5 mm <sup>2</sup>         |   |                                       |
| Process connection                                     |                    | 1", 1 1/2 NPT or BSP   |   | 1 1/2 NPT or BSP                      |
| Ingress Protection                                     |                    | IP 67  |   |                                       |
| Electrical protection                                  | Normal version:    | Class III  |   |                                       |
|  | Ex version:        | Limited overload power circuit<br>Ex protection mark: $\text{Ex II 1G EEx ia IIB T6}$<br>Ex power supply: $U_{max} = 30 V$ $I_{max} = 80 mA$ $P_{max} = 0.8 W$ |   |                                       |
| Mass   |                    | 2.3 kg with 0.5 m probe  | 1.9 kg with 3 m probe   | 4.5 kg with 3 m probe                 |

\* See also diagram in 3.2 and table under 5.2 \*\* Under development

## 2.2 TEMPERATURE DIAGRAM

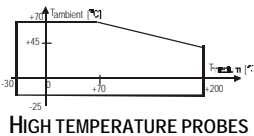
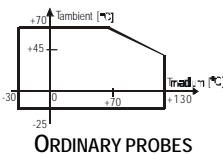

## 2.3 PRESSURE DIAGRAM

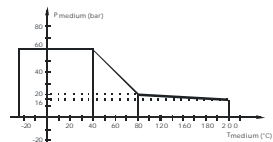

## 2.4 ORDER CODE

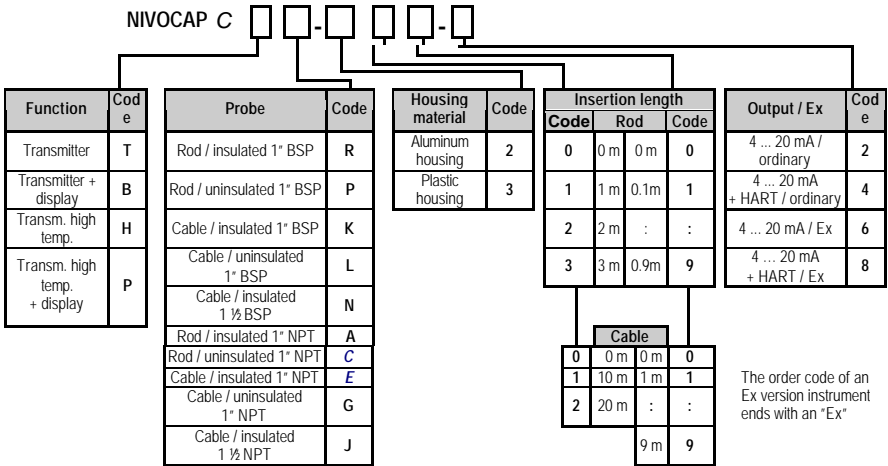

## 2.5 DIMENSION

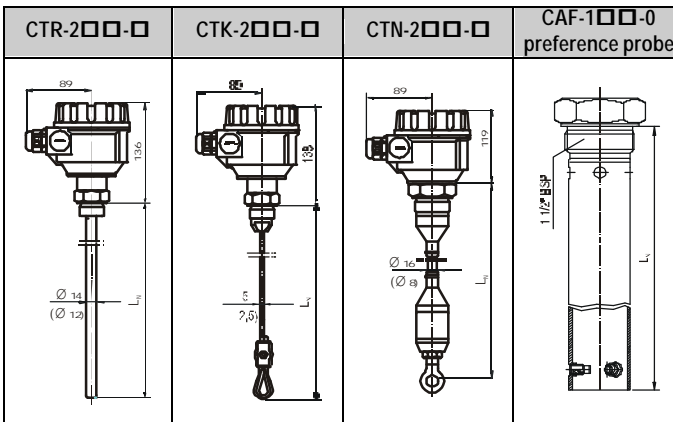

## 3. INSTALLATION

The NIVOCAP probes are mounted by 1" or 1 1/2" mounting connections (use S = 41 and S = 55 open end wrench, respectively). The active probe should be mounted vertically. Reference probe for tanks with nonconductive material should be parallel to the active probe. It is recommended to fix the bottom end of the cable probes. This can be accomplished by fixing the cable loop or bore hole to the tank bottom or by the use of weight.

## 4. WIRING

After removing the cover of the housing and removing display the wiring terminal becomes accessible. Wires of 0,5 ... 1,5 mm<sup>2</sup> cross section should be applied. The use of shielded cable is recommended.

Depending on the wiring arrangement the instrument is to be grounded either through the outer or the inner screw. Instruments in plastic housing should be grounded with the outer screw.

Electrostatic discharge through the inner terminal may cause damage; therefore the generally accepted procedures to avoid ESD should be applied. (E.g. to lead off the static charges, touch with hand a properly grounded part before opening the instrument).

After wiring and adjustment is accomplished check the gaskets and close the cover carefully.

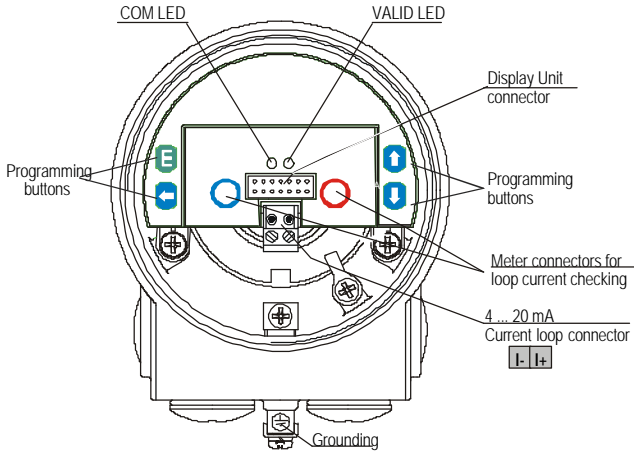

## 5. PUTTING INTO OPERATION, ADJUSTMENTS, PROGRAMMING

When connected to the power supply the instrument is immediately operational with the factory default settings. The VALID LED is lighting on the instrument operating within the specified measurement range. When the HART communication is going the COM LED is also on.

### FACTORY DEFAULT SETTINGS:

- 4 mA corresponds to 50 pF.
- 20 mA corresponds to 5 nF.
- Fault indication on current output: 22 mA
- Damping time is 10 s.

Fault will also be indicated by the blinking of the COM and VALID LEDs as below:

- Electronic failure – blinking steadily
- Level outside the measuring range set – double blinking
- Programming error – triple blinking

### 5.1 PROGRAMMING (ADJUSTMENT TO THE TANK)



Depending on the application the NIVOCAP C 200 will be programmed either with or without the SAP-202.

#### PROGRAMMING WITHOUT DISPLAY

Press the buttons in the appropriate sequence and watch the status of the LED's as described in the following tables. The left side LED in the table is the COM LED.



○ = LED off, ● = LED on, ◐ = LED blinking

#### Assignment of 4 and 20 mA to minimum and maximum levels

| Action  | LED state after action | Effect  |
|---|------------------------|---|
| 1) Push button  and retain press   | ○○                     | Programming mode entered                                  |
| 2) Push one of the buttons additionally and retain press for assignment<br><br> | ●●                     | 4 mA assigned to min level<br>20 mA assigned to max level |
| 3) Release buttons  | ○○                     | Programming completed                                     |

#### Setting fault indication by the current output

Output signal will be 3,8 mA or 22 mA, as long as fault prevails

| Action   | LED state after action | Effect                   |
|--|------------------------|--------------------------|
| 1) Push button  and retain press  | ○○                     | Programming mode entered |
| 2) Push one of the buttons additionally and retain press<br><br> | ●●                     | 3,8 mA<br>22,0 mA        |
| 3) Release buttons   | ○○                     | Programming completed    |

## Setting damping

| Action   | LED state after action | Effect                   |
|--|------------------------|--------------------------|
| 1) Push button (E) and retain press                      | ○○                     | Programming mode entered |
| 2) Push one of the buttons additionally and retain press | ●●                     | 3 s<br>10 s<br>60 s      |
| 3) Release buttons                                       | ○○                     | Programming completed    |

## Reset (return to FACTORY DEFAULT)

| Action   | LED state after action | Effect                   |
|--|------------------------|--------------------------|
| 1) Push button (E) and retain press                  | ○○                     | Programming mode entered |
| 2) Push the button (E) additionally and retain press | ●●                     | Return to DEFAULT        |
| 3) Release buttons                                   | ○○                     | Programming completed    |

## Assignment of intermediary current value to a given level

*Solution not requiring complete filling and emptying. Measure level by stick-yard and calculate relevant value of current*

| Action   | LED state after action | Effect  |
|--|------------------------|---|
| 1) Push button (E) and retain press  | ○○                     | Programming mode entered  |
| 2) Push one of the buttons additionally and retain press                             | ●●                     | Assignment of current nearer to 4 mA<br>Assignment of current nearer to 20 mA |
| 3) Release buttons Adjust value of calculated current by pushing buttons.            | ●●                     | Current value adjusted  |
| 4) Push button (E) for storing or push button (E) for 2 s to return to 4 mA (20 mA). | ●●                     | Current value stored  |
| 5) Release buttons   | ○○                     | Programming completed   |

Having finished programming, the LED's come to their operational status.

## 5.2 CONDITIONS OF EX APPLICATION

Temperature classification table

|                           |    |
|---------------------------|----|
| Temperature class         | T6 |
| T <sub>ambient max.</sub> | 70 |
| T <sub>medium max.</sub>  | 80 |

- The product should be powered by an intrinsically safe signal processor with EEx ia IIB or EEx ia IIC certification.
- The tank and the level measuring instrument shall be connected to an EP network with copper wiring  $q \geq 4 \text{ mm}^2$ .
- The Teflon coating of the rod and cable probes may be charged electrostatically, therefore:
  - The unit should only be used for level measurement of conductive medium and its specific resistance must not exceed  $10^4 \Omega\text{m}$ , even under the most unfavourable conditions and at the most unfavourable place.
  - The method and the speed of filling or emptying of the tank should be selected in accordance with the medium properties.
  - The electronic circuitry of the probe is grounded. An equipotential network should be formed along the intrinsically safe circuit. Distance between the transmitter and the intrinsically safe power supply (accommodated in the non-hazardous area) must not exceed 100 m.

## 6. MAINTENANCE, REPAIR

The device does not require routine maintenance. In some instances, however, the sensor may need occasional cleaning to remove surface deposits.

## 7. STORAGE CONDITIONS

Environment temperature: -13 °F to + 140 °F (-25 °C to +60 °C)

Relative humidity: up to 98 %

## 8. PERFORMANCE GUARANTEE

Since 1986, every instrument sold by *HITECH* has been guaranteed to perform in the application it originally was engineered and recommended for. Our company policy remains the same; every product sold comes with a written performance guarantee.

Should the equipment be unable to perform satisfactorily in your application and we are not able to correct the problem, we will accept the instrument in return and issue full credit.

This performance guarantee is valid for 60 days. Thereafter, our standard limited two years factory warranty goes into effect.

## *Hitech* Technologies, Inc.

---

301 Oxford Valley Road - Building 505A - Yardley, PA 19067-7706

Tel: 215. 321. 6012; Fax: 215. 321. 6067

Tech Support (Toll Free) 866-DrLevel or 888-NIVELCO

Email: [info@DrLevel.com](mailto:info@DrLevel.com) or [info@hitechtech.com](mailto:info@hitechtech.com)

Web Site: [www.DrLevel.com](http://www.DrLevel.com) or [www.hitechtech.com](http://www.hitechtech.com)