

Operating Instructions VEGAPULS 66 standpipe version 4 ... 20 mA/HART - four-wire

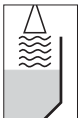

Contents

1 About this document

1.1	Function	4
1.2	Target group	4
1.3	Symbolism used	4

2 For your safety

2.1	Authorised personnel	6
2.2	Appropriate use	6
2.3	Warning about misuse	6
2.4	General safety instructions	6
2.5	CE conformity	7
2.6	Safety information for Ex areas	7
2.7	Environmental instructions	7

3 Product description

3.1	Configuration	8
3.2	Principle of operation	9
3.3	Adjustment	10
3.4	Storage and transport	10

4 Mounting

4.1	Mounting instructions	12
4.2	Mounting procedure	12
4.3	Mounting examples	13

5 Connecting to power supply

5.1	Preparing the connection	16
5.2	Connection procedure	17
5.3	Wiring plans, double chamber housing with cable entry	19

6 Set-up with the indicating and adjustment module PLICSCOM

6.1	Short description	21
6.2	Installing the indicating and adjustment module PLICSCOM	21
6.3	Adjustment system	23

6.4	Set-up procedure	24
6.5	Menu schematic	27
7	Set-up with PACTware™	
7.1	Connecting the PC	30
8	Maintenance and fault rectification	
8.1	Maintenance	32
8.2	Fault rectification	32
8.3	Repairing the instrument	33
9	Dismounting	
9.1	Dismounting procedure	34
9.2	Disposal	34
10	Supplement	
10.1	Technical data.	35
10.2	Dimensions.	43

1 About this document

1.1 Function

This operating instructions manual has all the information you need for quick set-up and safe operation of VEGAPULS 66. Please read this manual before you start set-up.

1.2 Target group

This operating instructions manual is directed to trained personnel. The contents of this manual should be made available to these personnel and put into practice by them.

1.3 Symbolism used



Information, tip, note

This symbol indicates helpful additional information.



Caution, warning, danger

This symbol informs you of a dangerous situation that could occur. Ignoring this cautionary note can impair the person and/or the instrument.



Ex applications

This symbol indicates special instructions for Ex applications.



List

The dot set in front indicates a list with no implied sequence.



Action

This arrow indicates a single action.

1 **Sequence**

Numbers set in front indicate successive steps in a procedure.

2 For your safety

2.1 Authorised personnel

All operations described in this operating instructions manual must be carried out only by trained and authorised specialist personnel. For safety and warranty reasons, any internal work on the instruments must be carried out only by VEGA personnel.

2.2 Appropriate use

VEGAPULS 66 is a sensor for continuous level measurement.

2.3 Warning about misuse

Inappropriate or incorrect use of the instrument can give rise to application-specific hazards, e.g. vessel overfill or damage of system components through incorrect mounting or setting.

2.4 General safety instructions

VEGAPULS 66 is a high-tech instrument requiring the strict observance of standard regulations and guidelines. Depending on the instrument version, the emitting frequencies of all VEGAPULS sensors are in the C or K band range. The exact emitting frequency is stated in the Technical data in the Supplement. Due to the low emitted power, which is far below the internationally approved limit values, there are no hazards to health if the instrument is used correctly. The instrument may also be used without restriction on the outside of closed metal vessels. The user must take note of the safety instructions in this operating instructions manual, the country-specific installation standards (e.g. the VDE regulations in Germany) as well as all prevailing safety regulations and accident prevention rules.

2.5 CE conformity

VEGAPULS 66 is in CE conformity with EMC (89/336/EWG), R & TTE (1999/5/EC), fulfils the Namur recommendation NE 21 and is in CE conformity with NSR (73/23/EWG).

Conformity has been judged acc. to the following standards:

- EMC:
 - Emission EN 61326: 1997 (class B)
 - Susceptibility EN 61326: 1997/A1: 1998
- R & TTE: I-ETS 300-440 Expert opinion No. 0043052-01/SEE, Notified Body No. 0499
- NSR: EN 61010-1: 2001.

2.6 Safety information for Ex areas

Please note the Ex-specific safety information for installation and operation in Ex areas. These safety instructions are part of the operating instructions manual and come with the Ex-approved instruments.

2.7 Environmental instructions

Protection of the environment is one of our most important duties. That is why we have introduced an environment management system with the goal of continuously improving company environmental protection. The environment management system is certified acc. to DIN EN ISO 14001.

Please help us fulfil this obligation by observing the environmental instructions in this manual:

- Chapter "Storage and transport"
- Chapter "Disposal"

3 Product description

3.1 Configuration

Scope of delivery

The scope of delivery encompasses:

- VEGAPULS 66 radar sensor
- documentation
 - this operating instructions manual
 - Ex-specific safety instructions (with Ex versions) and, if necessary, further certificates.

Components

VEGAPULS 66 consists of the following components:

- process fitting with standpipe antenna
- housing with electronics
- housing cover, optionally available with indicating/adjustment module PLICSCOM

The components are available in different versions.

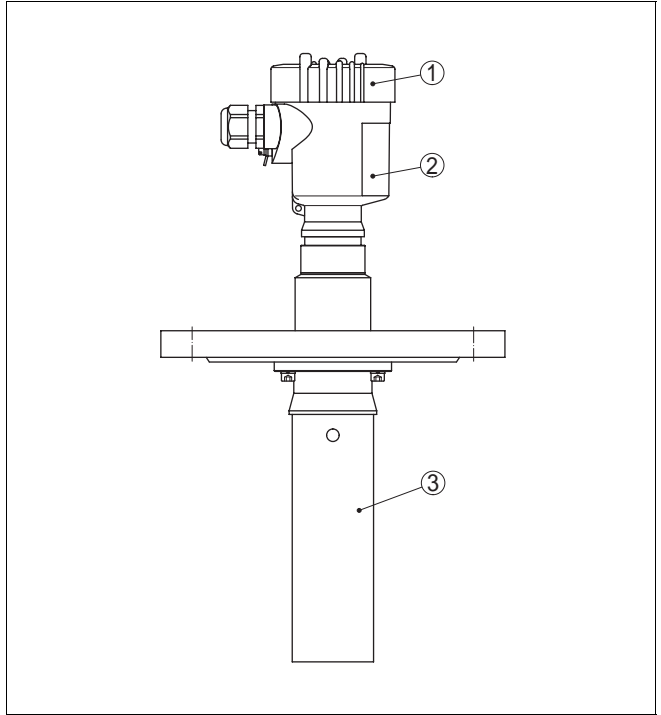

Fig. 1: VEGAPULS 66 in flange version up to 150°C with plastic housing

- 1 Housing cover with integrated PLICSCOM (optional)
- 2 Housing with electronics
- 3 Process fitting with standpipe antenna

3.2 Principle of operation

Area of application

VEGAPULS 66 is a radar sensor in C-band technology (emitting frequency approx. 6 GHz) for continuous level measurement.

A special version of VEGAPULS 66 is available for each area of application. The version with flange and standpipe antenna is particularly suitable for measurement of solvents and liquid gases. For very extreme process conditions such as 160 bar process pressure and 400°C process temperature, a graphite seal and a ceramic antenna cone are available.

Physical principle

The antenna of the radar sensor emits short radar pulses with a duration of approx. 1 ns. These radar pulses are reflected by the product and received by the antenna as echoes. The running time of the radar pulses from emission to reception is proportional to the distance and hence to the level. The determined level is converted into an appropriate output signal and outputted as measured value.

Power supply

Four-wire electronics with separate power supply.

The power supply range can differ depending on the instrument version. The exact range is stated in the Technical data in the Supplement.

The measured value transmission is carried out via the 4 ... 20 mA/HART output separated from the power supply.

3.3 Adjustment

VEGAPULS 66 can be adjusted with three different adjustment media:

- with the indicating and adjustment module PLICSCOM
- with an adjustment software acc. to FDT/DTM standard, e.g. PACTware™ and PC
- with a HART handheld

The entered parameters are generally saved in VEGAPULS 66, optionally also in PLICSCOM or in PACTware™.

3.4 Storage and transport**Packaging**

Your instrument was protected by packaging during transport. Its capacity to handle normal loads during transport is assured by a test acc. to DIN 55439.

The packaging consists of environment-friendly, recyclable cardboard. Dispose of the packing material via specialised recycling companies.

Material:

- Packaging of cardboard
- Padding of cardboard or PE foam

Storage and transport temperature

- Storage and transport temperature, see Supplement, Technical data, Ambient conditions
- Relative humidity 20 ... 85 %

4 Mounting

4.1 Mounting instructions

Select installation position

Select an installation position you can easily reach for mounting and connecting as well as later retrofitting of an indicating and adjustment module PLICSCOM. The housing can be rotated 330° without the use of any tools. You can also mount the adjustment and indicating module PLICSCOM in four different positions (each displaced by 90°).

4.2 Mounting procedure

Protection against moisture

Protect your VEGAPULS 66 against moisture penetration.

- Lead the connection cable downward in front of the cable entry

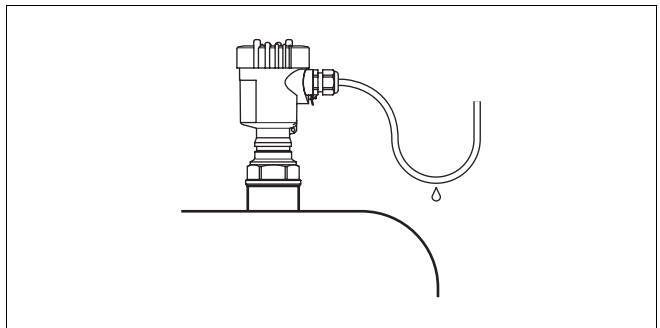

Fig. 2: Measures against moisture penetration

Rain and condensation water can thus drain off. This applies mainly to mounting outdoors, in areas where moisture is expected (e.g. by cleaning processes) or on cooled or heated vessels.

Use cable with round wire cross section and tighten the cable entry.

4.3 Mounting examples

Measuring range

The reference plane for the measuring range is the lower edge of the flange.

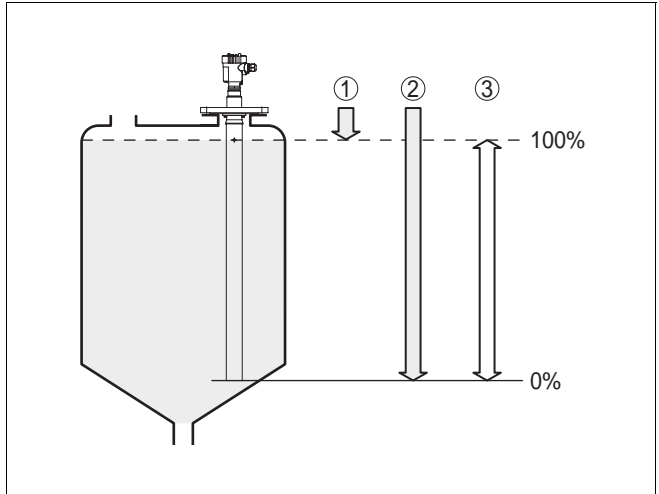

Fig. 3: Measuring range (operating range) and max. measuring distance

- 1 full
- 2 empty (max. measuring distance)
- 3 Measuring range

Standpipe antenna

Pipe antennas are preferred in vessels with installations and turbulence such as e.g. heating spirals or stirrers.

The standpipe antenna is also suitable for vessels with foam generation or the measurement of products with low dielectric constants (dielectric value > 1.6)

Standpipe antennas must reach up to the requested min. level as a measurement is only possible in the tube. If a good mixing of the product is important, a radar sensor with perforated surge pipe is recommended.

Turbulences

In case of turbulence or heavy product movements in the vessel, long standpipe antennas should be fixed on the vessel wall.

Dismounting

If the flange of VEGAPULS 66 was separated from the tube, e.g. for transport, make sure when mounting that

the polarisation marking is displaced by 90° to the ventilation hole. Take care during transport that the plastic tip of the radar sensor will not be damaged.

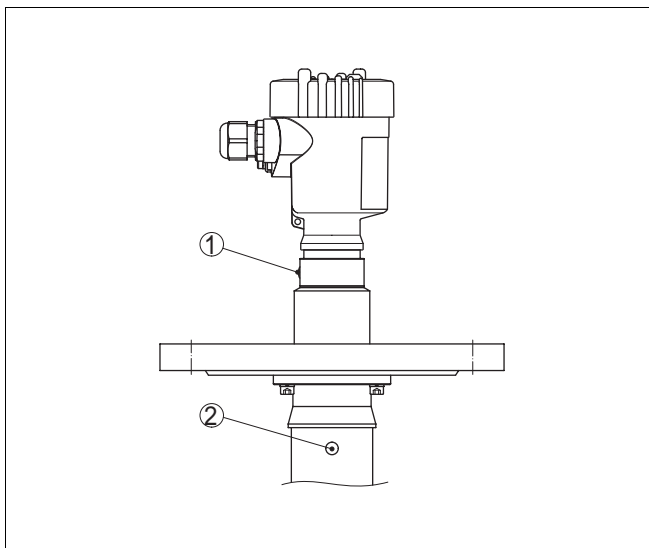

Fig. 4: Polarisation marking

- 1 Marking of the polarisation direction
- 2 Vent hole \varnothing 8 mm

Inflowing material

Do not mount the instruments in or above the filling stream.

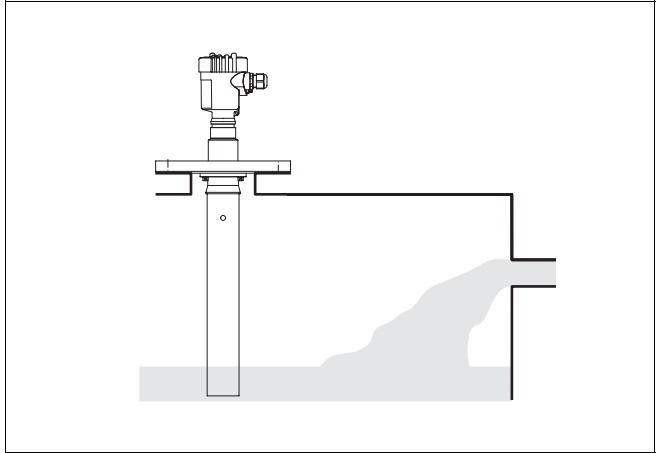

Fig. 5: Inflowing liquid

Adhesive products

The measurement in a standpipe is not recommended for very adhesive products.

Pressure

In case of gauge or low pressure in the vessel you should seal the process fitting. Check in advance, if the seal material is resistant against the measured product. The max. permissible pressure is stated in the Technical data in the Supplement or on the type label of the sensor.

5 Connecting to power supply

5.1 Preparing the connection

Note safety instructions

Always observe the following safety instructions:

- Connect only in the complete absence of line voltage
- If overvoltages are expected, overvoltage arresters should be installed.



Tip:

We recommend VEGA overvoltage arresters ÜS-F-LB-I and ÜSB 62-36G.X.

Take note of safety instructions for Ex applications



In hazardous areas you should take note of the appropriate regulations, conformity and type approval certificates of the sensors and power supply units.

Select voltage supply

Voltage supply and current output are carried on separate two-wire connection cables. The power supply range can differ depending on the instrument version. The exact range is stated in the Technical data in the Supplement.

With the standard version the current output can be operated ground-based, with the Exd version it must be operated floating.

This instrument is designed in protection class I. To maintain this protection class, it is absolutely necessary that the ground conductor is connected to the inner ground conductor terminal. Take note of the general installation regulations.

Connect VEGAPULS 66 generally to vessel ground (potential equalisation) or in case of plastic vessels to the next ground potential. A ground terminal is provided laterally on the instrument housing.

Select connection cable

An approved installation cable with PE conductor is necessary for power supply.

The 4 ... 20 mA current output is connected with standard two-wire cable. A cable outer diameter of 5 ... 9 mm ensures the seal effect of the cable entry. If electromagnetic interference is expected, we recommend the use of screened cable.

Screening and grounding

Connect the cable screen on both ends to ground potential. In the sensor, the screen must be connected directly to the inner ground terminal. The ground terminal outside on the housing must be connected to potential equalisation.

If potential equalisation currents are expected, the connection must be provided on the processing side via a ceramic capacitor (e.g. 1 nF, 1500 V). The low frequency potential equalisation currents are thus suppressed, the protective effect of the high frequency interference signals, however, remains.

Select connection cable for Ex applications



Take note of the corresponding installation regulations for Ex applications.

5.2 Connection procedure

Proceed as follows:

- 1 Unscrew the housing cover
- 2 Loosen compression nut of the cable entry
- 3 Remove approx. 10 cm of the cable mantle of the current output, strip approx. 1 cm insulation from the ends of the individual wires
- 4 Insert cable into the sensor through the cable entry
- 5 Lift the opening levers of the terminals with a screwdriver
- 6 Insert the wire ends into the open terminals according to the wiring plan
- 7 Press down the opening levers of the terminals, you will hear the terminal spring closing

- 8 Check the hold of the wires in the terminals by lightly pulling on them
 - 9 Connect screen to the inner ground terminal, connect the outer ground terminal to potential equalisation
 - 10 Tighten the compression nut of the cable entry, the seal ring must completely encircle the cable
 - 11 Connect the connection cable for power supply in the same way acc. to the wiring plan, in addition, connect ground conductor to the inner ground terminal
 - 12 Screw the housing cover back on
- The electrical connection is finished.



Fig. 6: Connection steps 5 and 6

5.3 Wiring plans, double chamber housing with cable entry

Overview

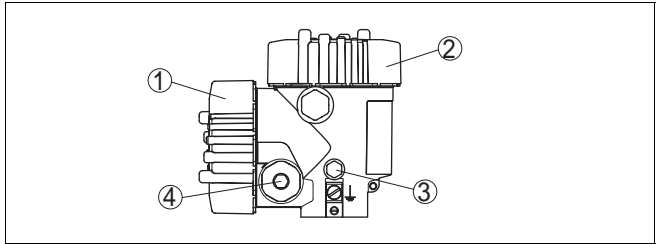

Fig. 7: Double chamber housing, non-Ex instrument or Exd instrument

- 1 Connection compartment
- 2 Electronics compartment
- 3 Breather element
- 4 Cable entry (pressure-tight with Exd)

Top view, electronics compartment (Exd and non-Ex)

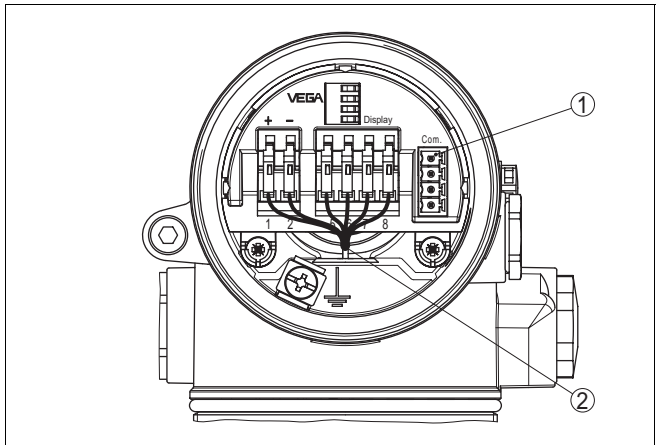

Fig. 8: Top view, electronics compartment, non-Ex instrument or Exd instrument

- 1 Plug connector for VEGACONNECT (I²C interface)
- 2 Internal connection cable to the connection compartment



Attention:

Never connect power supply in the electronics compartment, but only in the connection compartment.

Top view, connection compartment (Exd and non-Ex)

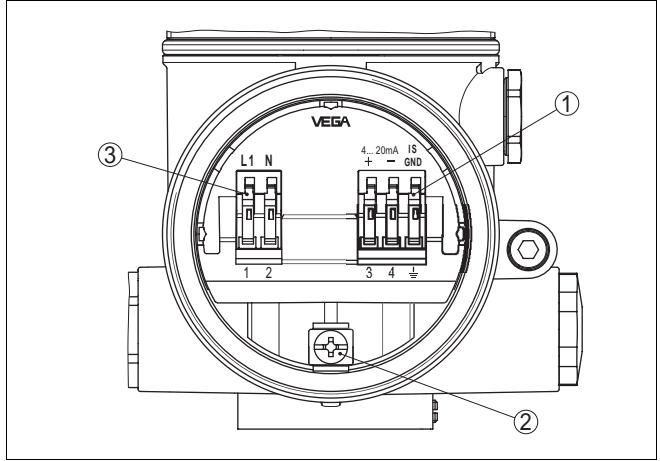

Fig. 9: Connection compartment, non-Ex instrument or Exd instrument

- 1 Spring-loaded terminals for 4 ... 20 mA output
- 2 Ground terminal for connection of the ground conductor and the cable screen
- 3 Spring-loaded terminals for power supply



Information:

Take note that the indicating and adjustment module PLICSCOM may be only used in the electronics compartment.

Wiring plan (Exd and non-Ex)

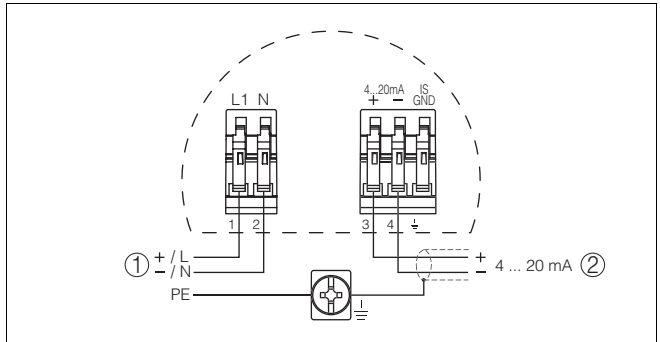

Fig. 10: Wiring plan, non-Ex instrument or Exd instrument

- 1 Power supply
- 2 4 ... 20 mA connection

6 Set-up with the indicating and adjustment module PLICSCOM

6.1 Short description

Function/Configuration

The indicating and adjustment module PLICSCOM is used for measured value display, adjustment and diagnosis. It can be mounted in the following housing versions and instruments:

- all sensors of the plics® instrument family, in the single as well as in the double chamber housing (optionally in electronics or connection compartment)
- external indicating instrument VEGADIS 61

6.2 Installing the indicating and adjustment module PLICSCOM

Insert/remove PLICSCOM

PLICSCOM can be inserted or removed at any time. An interruption of the power supply is not necessary.

To install, proceed as follows:

- 1 Unscrew housing cover
- 2 Place PLICSCOM in the desired position on the electronics (you can choose any one of four different positions - each displaced by 90°)
- 3 Press PLICSCOM lightly onto the electronics and turn it to the right until it snaps in
- 4 Screw housing cover with inspection window tightly back on

Removal is carried out in reverse order.

PLICSCOM is powered by the sensor, an additional connection is not necessary.



Fig. 11: Installation of PLICSCOM



Note:

If you intend to retrofit VEGAPULS 66 with PLICSCOM for continuous measured value indication, an increased cover with inspection glass is needed.

6.3 Adjustment system

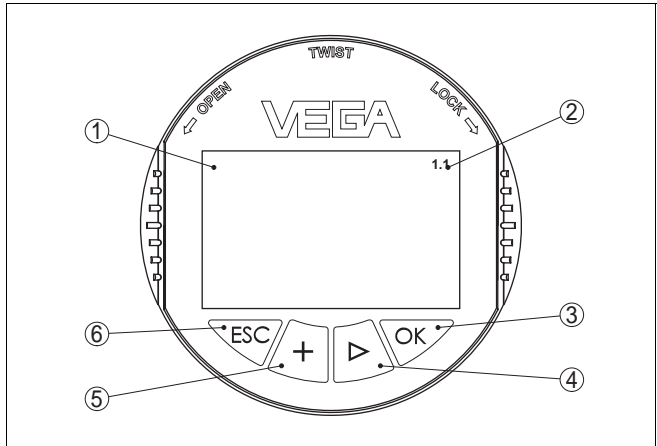

Fig. 12: Indicating and adjustment elements

1 **LC display for indication of:**

- measured value
- menu item
- parameter

2 **Indication of the menu item number**

3 **OK key:**

- move to the menu overview
- confirm selected menu
- edit parameter
- save value

4 **-> key to select:**

- menu change
- list entry
- editing position

5 **+ key:**

- modify value of a parameter

6 **ESC key:**

- interrupt input
- jump to the next higher menu

Adjustment system

The sensor is adjusted via the four keys of the indicating and adjustment module PLICSCOM. The LC display indicates the individual menu items. The functions of the individual keys are shown in the above illustration. Approx. 10 minutes after the last pressing of a key, an automatic reset to measured value display is triggered. Any values not confirmed with **OK** will not be saved.

6.4 Set-up procedure

Switching on phase

After VEGAPULS 66 is connected to power supply, the instrument carries out a self-test for approx. one minute. The following steps are carried out:

- internal check of the electronics
- indication of the instrument type, the firmware version as well as the sensor-TAGs (sensor name)
- the output signal jumps briefly to the set fault current (HART sensor), i.e. the status byte changes the fault value (Profibus PA and FF sensors)

Then the actual measured value is displayed and the corresponding current (HART sensor) or the digital output signal is transmitted to the cable (Profibus PA and FF sensors) ¹⁾.

Parameter adjustment

Since VEGAPULS 66 is a distance measuring instrument, it measures the distance from itself to the product surface. In order to have the actual level displayed, an allocation of the measured distance to the percentage height must be carried out. To make this adjustment, the full and empty distances in the vessel are entered. If these values are not known, it is also possible to carry out the adjustment with other distances, e.g. 10 % and 90 %. Starting point for these distance values is always the seal surface of the thread or flange. The actual level is then calculated on the basis of these entered values. At the same time, the operating range of the sensor is limited from the maximum range to the requested range.

The real product level during this adjustment is not important, because the min./max. adjustment is always carried out without changing the product level. These settings can be made ahead of time without the instrument having to be installed.

¹⁾

¹⁾ The values correspond to the actual level as well as to the settings already carried out, e.g. default setting.

In the main menu item "Basic adjustment", the individual submenu items should be selected one after the other and provided with the correct parameter values. This will ensure an optimum adjustment of the measurement.



Note:

With HART multidrop and Profibus PA, the address setting should be carried out first. You will find a description of this in the operating instructions manual of PLICSCOM.

Start your parameter adjustment with the menu items of the basic adjustment:

Carrying out min. adjustment

Proceed as follows:

- 1 Move from the measured value display to the main menu by pushing **[OK]**.

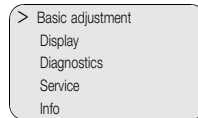

- 2 Select the menu item *Basic adjustment* with **[->]** and confirm with **[OK]**. Now the menu item "Min. adjustment" is displayed.

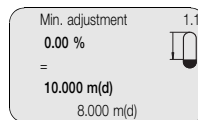

- 3 Prepare the percentage value for editing with **[OK]** and set the cursor to the requested position with **[->]**. Enter the requested % value with **[+]** and save with **[OK]**. The cursor jumps now to the distance value.
- 4 Enter the appropriate distance value in m/f (corresponding to the percentage value) for the empty vessel (e.g. distance from the sensor to the vessel bottom).
- 5 Save the settings with **[OK]** and move to max. adjustment with **[->]**.

Carrying out max. adjustment

Proceed as follows:

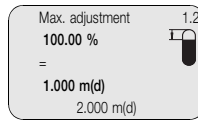

- 1 Prepare the percentage value for editing with **[OK]** and set the cursor to the requested position with **[->]**. Set the requested % value with **[+]** and save with **[OK]**. The cursor jumps now to the distance value.
- 2 Enter the appropriate distance value in m/ft (corresponding to the percentage value) for the full vessel. Please remember that the max. level must be below the radar antenna.
- 3 Save the settings with **[OK]** and move to medium selection with **[->]**.

Medium selection

Each medium has different reflection characteristics.

Liquids have different reflection characteristics depending on their conductivity and dielectric constant. For this reason there are different options under the menu item Liquid such as *Solvents*, *Chemical mixtures* and *Water based*.

Through this additional selection, the sensor is adapted to the product and its reliability, particularly when the product has poor reflective properties, is considerably increased.

Enter the requested parameters via the appropriate keys, save your settings and jump to the next menu item with the **[->]** key.

Damping

To suppress fluctuations in the measured value display, e. g. by agitated product surfaces, an integration time can be set. This time can be between 0 and 999 seconds. Please note that the reaction time of the entire measurement will be longer and the sensor will react to quick changes of the measured value with a corresponding delay. In general, a time of a few seconds is sufficient to smooth the measured value display.

Enter the requested parameters via the appropriate keys, save your settings and jump to the next menu item with the **[→]** key.

Linearisation curve

A linearisation is necessary for all vessels in which the vessel volume does not increase linearly with the level, e.g. in a cylindrical tank or spherical tank - and the indication and output of the volume is requested. Corresponding linearisation curves are preprogrammed for these vessels. They represent the correlation between level percentage and vessel volume. By activating the appropriate curve, the volume percentage of the vessel is displayed correctly. If the volume should not be displayed in percent, but e.g. in l or kg, it is possible to set a scaling in the menu item "Display".

Enter the requested parameters via the appropriate keys, save your settings and jump to the next menu item with the **[→]** key.

Sensor-TAG

In this menu item you can enter a clear designation for the sensor, e.g. the measurement loop name or the tank or product designation. In digital systems and in the documentation of larger plants, a unique designation should be entered for exact identification of individual measuring sites.

With this menu item the basic adjustment is finished and you can now return to the main menu with the **[ESC]** key.

Additional settings

Additional adjustment and diagnosis options such as e.g. scaling, simulation or echo curve presentation are shown in the following menu schematic. You will find a detailed description of these menu items in the operating instructions manual of the indicating and adjustment module PLICSCOM.

6.5 Menu schematic

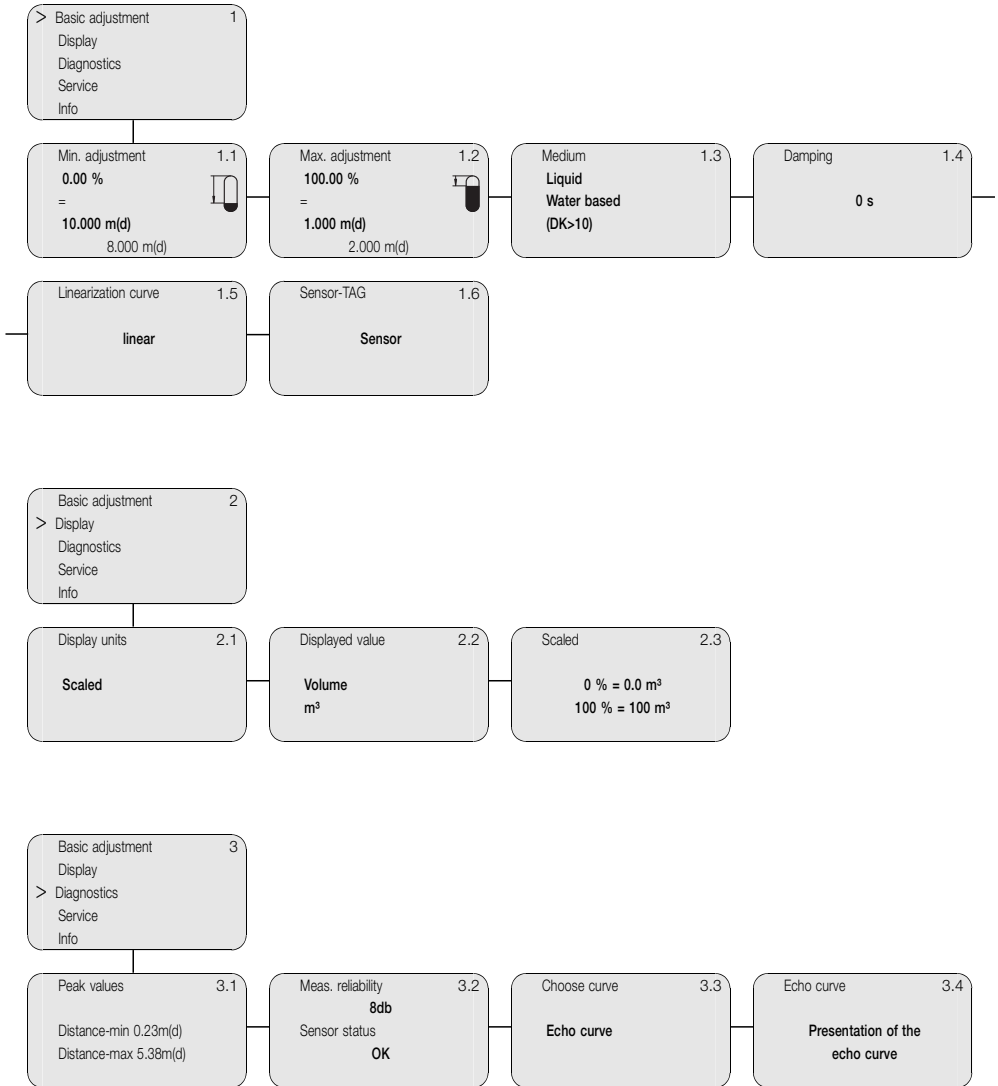

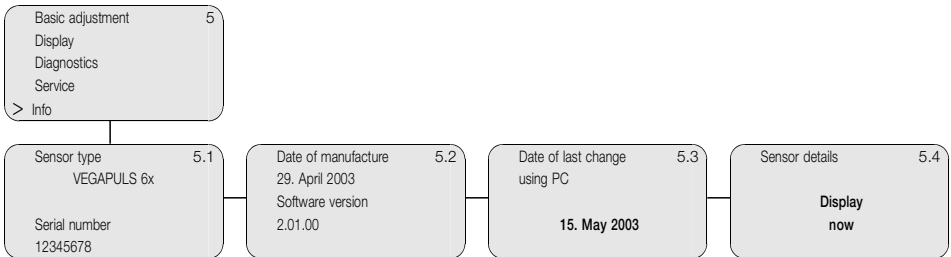
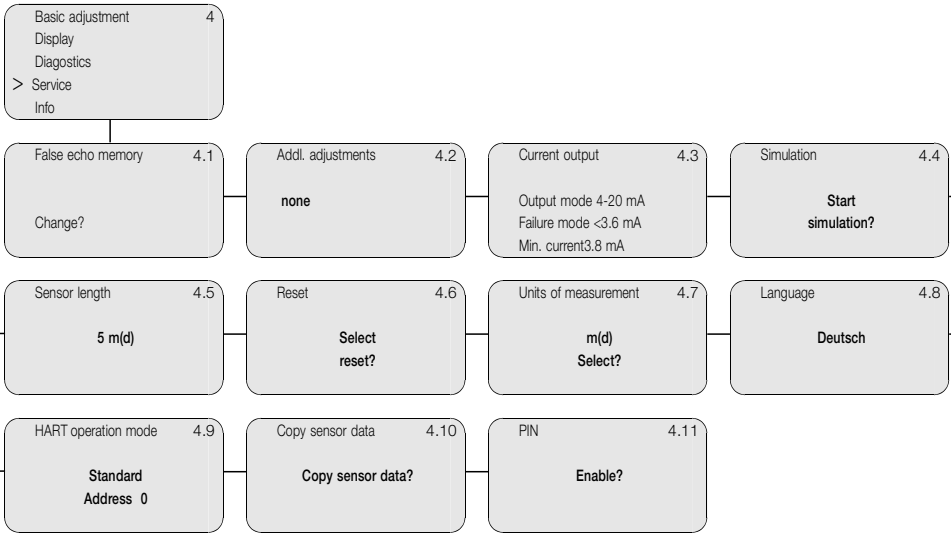
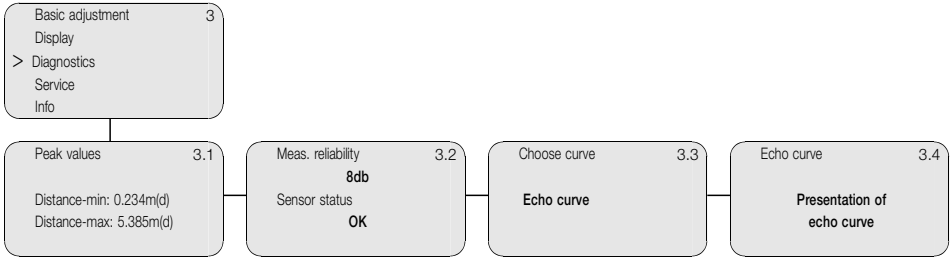

7 Set-up with PACTware™

7.1 Connecting the PC

Connecting the PC directly to the sensor

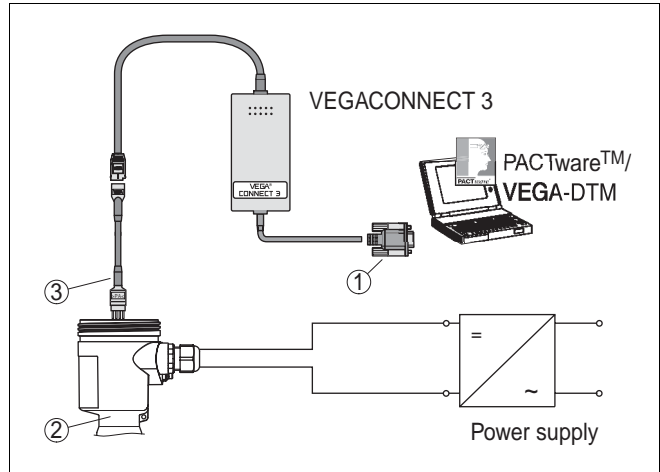

Fig. 13: PC connected directly to the sensor

- 1 RS232 connection
- 2 VEGAPULS 66
- 3 I²C adapter cable for VEGACONNECT 3
- 4 I²C bus plug

Necessary components:

- VEGAPULS 66
- PC with PACTware™ and suitable VEGA-DTM
- VEGACONNECT 3 with I²C adapter cable (article no. 2.27323)
- power supply unit

**Tip:**

Further set-up steps are described in the operating instructions manual *DTM Collection/PACTware* attached to each CD and which can be downloaded from our homepage. A detailed description is available in the online help of PACTware™ and the VEGA-DTMs.

Connecting the PC to the signal cable

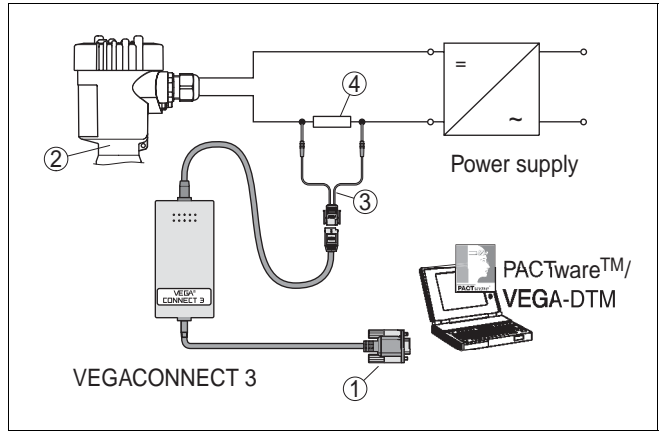

Fig. 14: PC connected to the signal cable

- 1 RS232 connection
- 2 VEGAPULS 66
- 3 VEGACONNECT 3 adapter cable for HART
- 4 HART resistance 250 Ohm

Necessary components:

- VEGAPULS 66
- PC with PACTware™ and suitable VEGA-DTM
- VEGACONNECT 3 with adapter cable for HART
- HART resistance 250 Ohm
- power supply unit

**Note:**

With power supply units with integrated HART resistance, an additional external resistance is no longer necessary. In such cases, VEGACONNECT 3 can be connected in parallel to the power supply.

8 Maintenance and fault rectification

8.1 Maintenance

In normal operation with appropriate use, VEGAPULS 66 is completely maintenance-free.

8.2 Fault rectification

Checking the 4 ... 20 mA signal

Connect a hand-multimeter with the suitable measuring range acc. to the wiring plan.

? 4 ... 20 mA signal not stable

- level fluctuations
- set integration time via PLICSCOM or PACTware™

? 4 ... 20 mA signal missing

- incorrect connection to power supply
- check connection acc. to chapter "Connection procedure" and correct if necessary acc. to chapter "Wiring plans"
- no power supply
- check cables for line break, repair if necessary
- power supply too low or load resistance too high
- check and adapt if necessary

? Current signal more than 22 mA or 0 mA

- electronics module defective
- exchange instrument or return for repair



Fault messages via PLICSCOM

In Ex applications, the regulations for the wiring of intrinsically safe circuits must be observed.

? E013

- no measured value available
- sensor in boot phase
- sensor does not find an echo, e.g. due to wrong installation or parameter adjustment

? E017

- adjustment span too small
- carry out a new adjustment, increase distance between min. and max. adjustment

? E036

- no operable sensor software
- carry out software update or return instrument for repair

? E042/E043

- hardware error, electronics defective
- exchange instrument or return for repair

8.3 Repairing the instrument

If it is necessary to repair VEGAPULS 66, please send the instrument to the following address:

VEGA Grieshaber KG; Repair department; Am Hohenstein 113; 77761 Schiltach/Germany

9 Dismounting

9.1 Dismounting procedure

Take note of chapters "Mounting" and "Connecting to power supply" and carry out the listed steps in reverse order.

9.2 Disposal

VEGAPULS 66 consists of materials which can be recycled by specialised recycling companies. We have purposely designed the electronic modules to be easily separable. Mark the instrument as scrap and dispose of it according to government regulations (electronic scrap ordinance, etc. ...).

Materials: see Technical data

If you cannot dispose of the instrument properly, please contact us about disposal methods or return.

10 Supplement

10.1 Technical data

General data

Materials, wetted parts

- process connection flanges DN 50 ... DN 250, 2" ... 10":
stainless steel 1.4435, Hastelloy C22
2.4602
- antenna PTFE (TFM 1600), ceramic (99.9 % AL₂O₃)
- seal antenna system Viton, Kalrez Spectrum 6375, graphite
- standpipe stainless steel 1.4435, Hastelloy C22
2.4602

Materials, non-wetted parts

- housing plastic PBT (Polyester), Alu-die casting
powder-coated, stainless steel 1.4435
- seal ring between housing and housing cover NBR (stainless steel housing), silicone (Alu/
plastic housing)
- inspection window with housing cover for PLICSCOM Polycarbonate
- ground terminal stainless steel 1.4571/1.4435

Weight without standpipe

6.3 ... 136.0 kg (depending on flange size,
pressure stage and housing material)

Standpipe weight

3.2 kg/m

Output variable

Output signal	4 ... 20 mA/HART
Resolution	1.6 μ A
Fault signal	current output unchanged, 20.5 mA, 22 mA, < 3.6 mA (adjustable)
Current limitation	22 mA
Load	
– 4-wire sensor	max. 500 Ohm ²⁾
– 2-wire sensor	see load diagram in Power supply
Integration time (63% of the input variable)	0 ... 999 s, adjustable
Rise time	150 ms (ti : 0 s, 0 ... 100 %)
Fulfilled Namur recommendation	NE 43

Input variable

Parameter	distance between lower edge of flange of the sensor and product surface
Min. distance	0 mm
Measuring range	up to 4 m

Accuracy (similar to DIN V 19259-1 and IEC 60770-1)

Reference conditions acc. to IEC 60770-1	
– temperature	18 ... 30°C
– relative humidity	45 ... 75 %
– pressure	860 ... 1060 mbar (86 ... 106 kPa)
Determination of characteristics	limit point adjustment acc. to DIN 16086
Characteristics	linear

²⁾
²⁾ with inductive load, ohmic share at least 25 Ohm/mH

Characteristics curve deviation and measurement characteristics³⁾

Average temperature coefficient of the zero signal (temperature error)	0.06 %/10 K
Resolution, general	max. 1 mm
Frequency	C-band (6 GHz technology)
Interval	approx. 1 s
Adjustment time ⁴⁾	> 1 s (depending on the parameter adjustment)
Max. emitted power	< 25 mW EIRP ⁵⁾
Received average emitted power reaching an object directly in front of the antenna	
– distance 1 m	0.4 ... 3.2 nW per cm ² (0.4 ... 3.2 x 10 ⁻⁹ W/cm ²)
– distance 5 m	0.02 ... 0.13 nW per cm ² (0.02 ... 0.13 x 10 ⁻⁹ W/cm ²)
Accuracy	see diagram

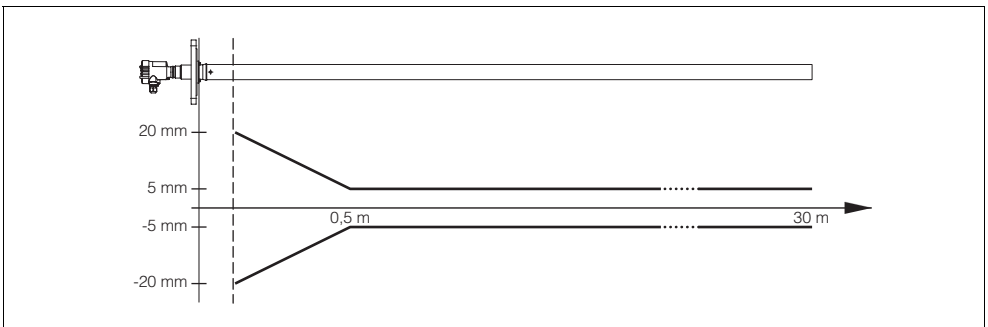

Fig. 15: Accuracy VEGAPULS 66

³⁾ In relation to the nominal range, incl. hysteresis and repeatability, determined acc. to the limit point method.
⁴⁾ Time required to output the correct level (max. 10 % deviation) after a sudden level change.
⁵⁾ EIRP: Equivalent isotropically radiated power.

Ambient conditions

Ambient, storage and transport temperature

- without PLICSCOM -40 ... +80°C
 - with PLICSCOM -40 ... +70°C
-

Process conditions

Process temperature (measured on the flange)

- coupling cone PTFE/seal Viton -40 ... +150°C
- coupling cone PTFE/seal Kalrez 6375 -15 ... +150°C
- coupling cone ceramic/seal graphite -60 ... +250°C (+400°C with temperature adapter)

Vessel pressure (note nominal pressure stage of the flange and temperature rating!)

- coupling cone PTFE -100 ... +4000 kPa (-1 ... 40 bar) at PN 40
 - coupling cone ceramic -100 ... +6400 kPa (-1 ... 64 bar) at PN 64
 - flange DN 50 to DN 150 C PN 16 (-60 ... +350°C) 1600 kPa (16 bar)
 - flange DN 200 C PN 16 (-60 ... +200/350°C) 1600/1200 kPa (16/12 bar)
 - flange DN 250 C PN 16 (-60 ... +200/350°C) 1600/1000 kPa (16/10 bar)
 - flange DN 50 F/N PN 40 (-60 ... +350°C) 4000 kPa (40 bar)
 - flange DN 80 and DN 100 F/N PN 40 (-60 ... +200/350°C) 4000/3200 kPa (40/32 bar)
 - flange DN 150 F/N PN 40 (-60 ... +100/350°C) 4000/3200 kPa (40/26 bar)
 - flange DN 200 F/N PN 40 (-60 ... +20/350°C) 3700/2300 kPa (37/23 bar)
 - flange DN 250 F/N PN 40 (-60 ... +20/350°C) 3400/2100 kPa (34/21 bar)
 - flange DN 50 F/N PN 64 (-60 ... +350°C) 6400 kPa (64 bar)
 - flange DN 80 F/N PN 64 (-60 ... +200/350°C) 6400/5400 kPa (64/54 bar)
 - flange DN 100 F/N PN 64 (-60 ... +100/350°C) 6400/3900 kPa (64/39 bar)
 - flange DN 150 F/N PN 64 (-60 ... +20/350°C) 6400/3900 kPa (64/39 bar)
-

- flange DN 200 F/N PN 64 (-60 ... +20/ 5600/3400 kPa (56/34 bar)
350°C)
- flange DN 250 F/N PN 64 (-60 ... +20/ 5000/3100 kPa (50/31 bar)
350°C)
- flange ANSI 2" ... 10" 150 lb/sq. in. (- 150 lbs/sq. in.
60 ... +350°C)
- flange ANSI 2" ... 10" 300 lb/sq. in. (- 300 lbs/sq. in.
60 ... +350°C)
- flange ANSI 2" ... 10" 600 lb/sq. in. (- 600 lbs/sq. in.
60 ... +350°C)
- flange ANSI 2" ... 6" 900 lb/sq. in. (- 900 lbs/sq. in.
60 ... +350°C)
- flange ANSI 8" ... 10" MF small, TG 900 lbs/sq. in.
small/large 900 lb/sq. in. (-
60 ... +350°C)

Vibration resistance

mechanical vibrations with 4 g and
5 ... 100 Hz ⁶⁾⁶⁾⁶⁾ Tested acc. to the reg. of the German Lloyd, GL-directive 2

Electromechanical data

Cable entry/plug (depending on the version)

- single chamber housing
 - 1 x cable entry M20x1.5 (cable- \emptyset 5 ... 9 mm), 1 x blind stopper M20x1.5
 - or:
 - 1 x closing cap 1/2 NPT, 1 x blind stopper 1/2 NPT
 - or:
 - 1 x plug M12x1, 1 x blind stopper M20x1.5
- double chamber housing
 - 1 x cable entry M20x1.5 (cable- \emptyset 5 ... 9 mm), 1 x blind stopper M20x1.5
 - or:
 - 1 x closing cap 1/2 NPT, 1 x blind stopper 1/2 NPT
 - or:
 - 1 x plug M12x1, 1 x blind stopper M20x1.5

Spring-loaded terminals

for wire cross sections up to 2.5 mm²

Indicating and adjustment module PLICSCOM

Power supply and data transmission	through sensor via gold-plated sliding contacts (I ² C bus)
Display	LC display in full dot matrix
Adjustment elements	4 keys
Protection	IP 20 (mounted into sensor without cover: IP 40)
Materials	
– housing	ABS
– inspection window	Polyester foil

Power supply

Power supply

– non-Ex and Ex d instrument

20 ... 72 V DC, 20 ... 253 V AC, 50/60 Hz

Power consumption

max. 4 VA, 2.1 W

Electrical protective measures

Protection

IP 66/IP 67

Overvoltage category

III

Protection class

I

Approvals ⁷⁾

ATEX II 1G, 1/2G, 2G EEx ia IIC T6,

ATEX II 1/2G, 2G EEx d ia IIC T6, WHG,

ship approvals

⁷⁾

⁷⁾ Deviating data with Ex applications: see separate safety instructions

10.2 Dimensions

VEGAPULS 66

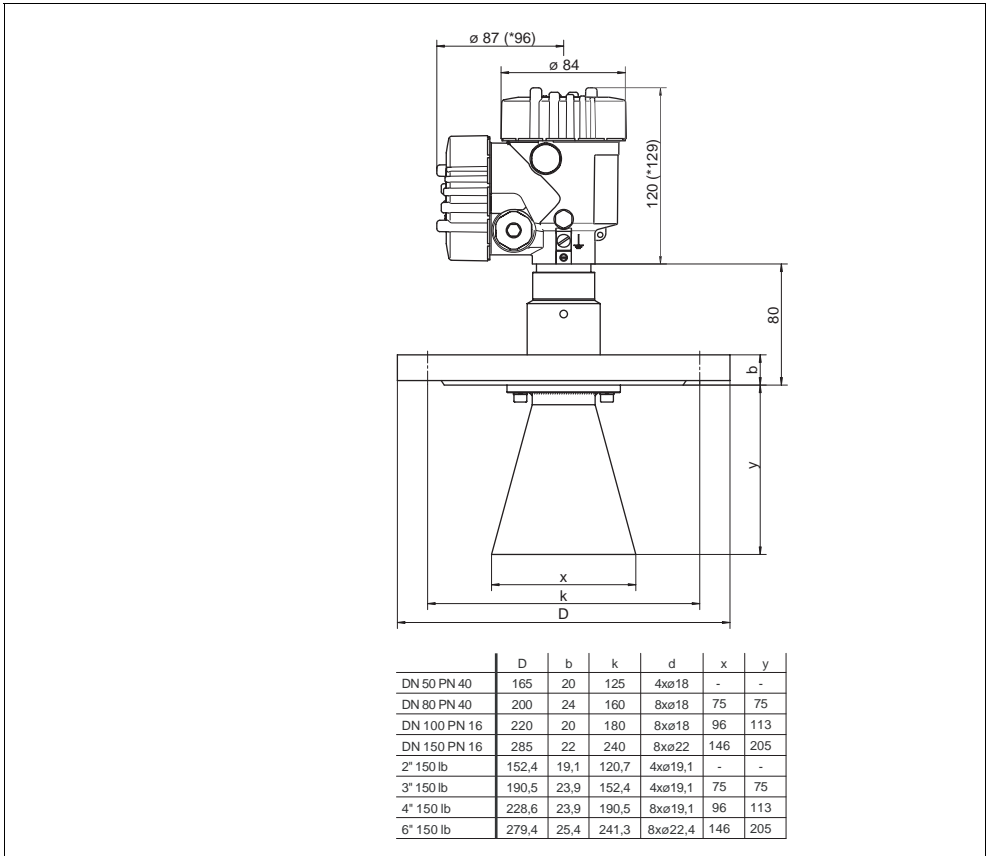

Fig. 16: VEGAPULS 66 in standard version

* dimension with integrated PLICSCOM

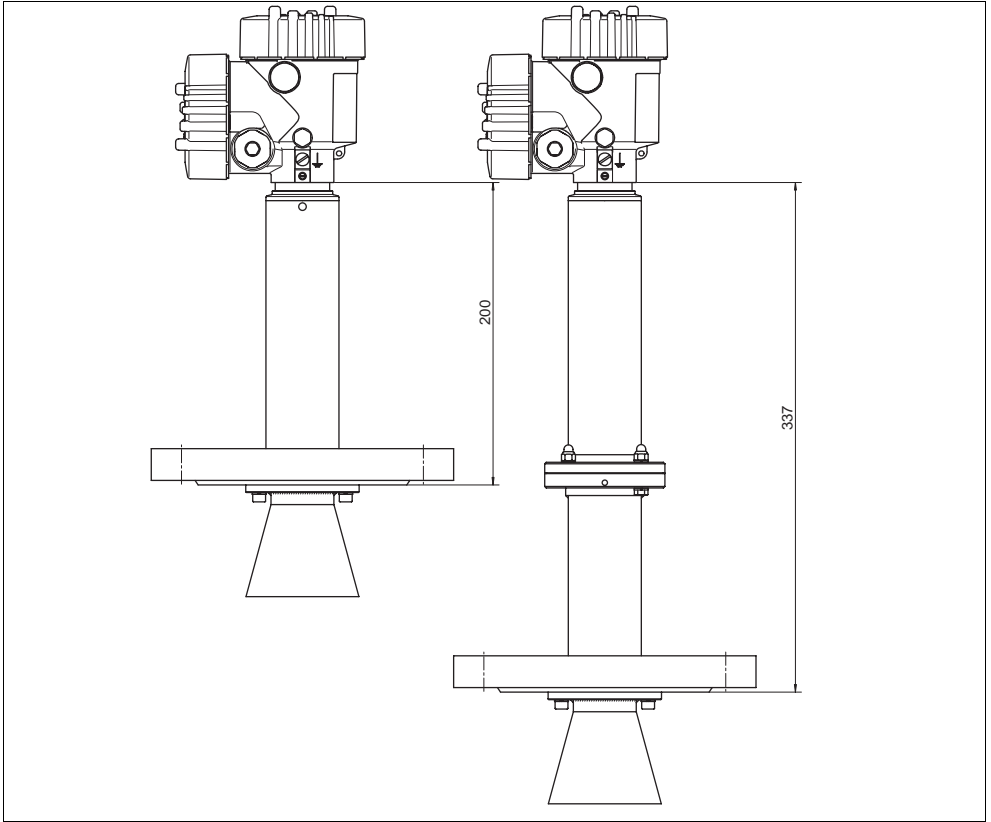

Fig. 17: VEGAPULS 66 for process temperatures up to 250°C or 400°C
* dimension with integrated PLICSCOM

