

## Operating Instructions VEGAPULS 62 standpipe version 4 ... 20 mA/HART

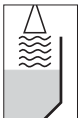

## Contents

### 1 About this document

1.1	Function . . . . .	4
1.2	Target group . . . . .	4
1.3	Symbolism used . . . . .	4

### 2 For your safety

2.1	Authorised personnel . . . . .	6
2.2	Appropriate use . . . . .	6
2.3	Warning about misuse . . . . .	6
2.4	General safety instructions . . . . .	6
2.5	Environmental instructions . . . . .	6

### 3 Product description

3.1	Configuration . . . . .	8
3.2	Principle of operation . . . . .	9
3.3	Adjustment . . . . .	10
3.4	Storage and transport . . . . .	10

### 4 Mounting

4.1	Mounting instructions . . . . .	11
4.2	Mounting procedure . . . . .	11
4.3	Mounting examples . . . . .	12

### 5 Connecting to power supply

5.1	Preparing the connection . . . . .	16
5.2	Connection procedure . . . . .	17
5.3	Wiring plans, single chamber housing . . . . .	19
5.4	Wiring plans, double chamber housing . . . . .	21

### 6 Set-up with the indicating and adjustment module PLICSCOM

6.1	Short description . . . . .	23
6.2	Installing the indicating and adjustment module PLICSCOM . . . . .	23
6.3	Adjustment system . . . . .	25
6.4	Set-up procedure . . . . .	26
6.5	Menu schematic . . . . .	28

**7 Set-up with PACTware™**

7.1 Connecting the PC . . . . .	31
---------------------------------	----

**8 Maintenance and fault rectification**

8.1 Maintenance . . . . .	32
8.2 Fault rectification . . . . .	32
8.3 Exchanging the cable/rod . . . . .	33
8.4 Repairing the instrument . . . . .	34

**9 Dismounting**

9.1 Dismounting procedure . . . . .	35
9.2 Disposal . . . . .	35

**10 Supplement**

10.1 Technical data . . . . .	36
10.2 Dimensions . . . . .	43

# 1 About this document

## 1.1 Function

This operating instructions manual has all the information you need for quick set-up and safe operation of VEGAPULS 62. Please read this manual before you start set-up.

## 1.2 Target group

This operating instructions manual is directed to trained personnel. The contents of this manual should be made available to these personnel and put into practice by them.

## 1.3 Symbolism used



### Information, tip, note

This symbol indicates helpful additional information.



### Caution, warning, danger

This symbol informs you of a dangerous situation that could occur. Ignoring this cautionary note can impair the person and/or the instrument.



### Ex applications

This symbol indicates special instructions for Ex applications.



### List

The dot set in front indicates a list with no implied sequence.



### Action

This arrow indicates a single action.

## 1 **Sequence**

Numbers set in front indicate successive steps in a procedure.

## 2 For your safety

### 2.1 Authorised personnel

All operations described in this operating instructions manual must be carried out only by trained and authorised specialist personnel. For safety and warranty reasons, any internal work on the instruments must be carried out only by VEGA personnel.

### 2.2 Appropriate use

VEGAPULS 62 is a sensor for continuous level measurement.

### 2.3 Warning about misuse

Inappropriate or incorrect use of the instrument can give rise to application-specific hazards, e.g. vessel overfill or damage of system components through incorrect mounting or setting.

### 2.4 General safety instructions

VEGAPULS 62 is a high-tech instrument requiring the strict observance of standard regulations and guidelines. Depending on the instrument version, the emitting frequencies of all VEGAPULS sensors are in the C or K band range. The exact emitting frequency is stated in the Technical data in the Supplement. Due to the low emitted power, which is far below the internationally approved limit values, there are no hazards to health if the instrument is used correctly. The instrument may also be used without restriction on the outside of closed metal vessels. The user must take note of the safety instructions in this operating instructions manual, the country-specific installation standards (e.g. the VDE regulations in Germany) as well as all prevailing safety regulations and accident prevention rules.

## 2.5 CE conformity

VEGAPULS 62 is in CE conformity with EMC (89/336/EWG), R & TTE (1999/5/EC), fulfils the Namur recommendation NE 21 and is in CE conformity with NSR (73/23/EWG).

Conformity has been judged acc. to the following standards:

- EMC:
  - Emission EN 61326: 1997 (class B)
  - Susceptibility EN 61326: 1997/A1: 1998
- R & TTE: I-ETS 300-440 Expert opinion No. 0043052-02/SEE, Notified Body No. 0499
- NSR: EN 61010-1: 2001.

## 2.6 Safety information for Ex areas

Please note the Ex-specific safety information for installation and operation in Ex areas. These safety instructions are part of the operating instructions manual and come with the Ex-approved instruments.

## 2.7 Environmental instructions

Protection of the environment is one of our most important duties. That is why we have introduced an environment management system with the goal of continuously improving company environmental protection. The environment management system is certified acc. to DIN EN ISO 14001.

Please help us fulfil this obligation by observing the environmental instructions in this manual:

- Chapter "Storage and transport"
- Chapter "Disposal"

### 3 Product description

#### 3.1 Configuration

##### Scope of delivery

The scope of delivery encompasses:

- VEGAPULS 62 radar sensor
- documentation
  - this operating instructions manual
  - Ex-specific safety instructions (with Ex versions) and, if necessary, further certificates.

##### Components

VEGAPULS 62 consists of the following components:

- process fitting with standpipe antenna
- housing with electronics
- housing cover, optionally available with indicating/adjustment module PLICSCOM

The components are available in different versions.

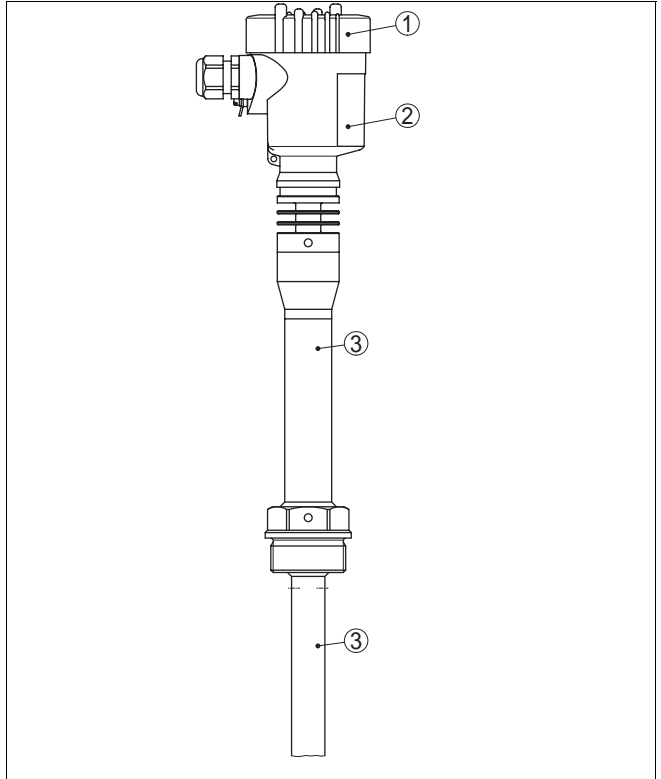

*Fig. 1: VEGAPULS 62 in threaded version up to 200°C with plastic housing*

- 1 Housing cover with integrated PLICSCOM (option)*
- 2 Housing with electronics*
- 3 Process fitting with standpipe antenna*

## 3.2 Principle of operation

### Area of application

VEGAPULS 62 is a radar sensor in K-band technology (emitting frequency approx. 26 GHz) for continuous level measurement.

A suitable version is available for the respective area of application of VEGAPULS 62.

The version with standpipe is particularly suitable for the measurement of solvents and liquid gases in vessels with small process connections under difficult process conditions.

### Physical principle

The antenna of the radar sensor emits short radar pulses with a duration of approx. 1 ns. These radar pulses are reflected by the product and received by the antenna as echoes. The running time of the radar pulses from emission to reception is proportional to the distance and hence to the level. The determined level is converted into an appropriate output signal and outputted as measured value.

### Power supply

Two-wire electronics 4 ... 20 mA/HART for power supply and measured value transmission via the same cable.

The power supply range can differ depending on the instrument version. The exact range is stated in the Technical data in the Supplement.

## 3.3 Adjustment

VEGAPULS 62 can be adjusted with three different adjustment media:

- with the indicating and adjustment module PLICSCOM
- with an adjustment software acc. to FDT/DTM standard, e.g. PACTware™ and PC
- with a HART handheld

The entered parameters are generally saved in VEGAPULS 62, optionally also in PLICSCOM or in PACTware™.

### 3.4 Storage and transport

#### Packaging

Your instrument was protected by packaging during transport. Its capacity to handle normal loads during transport is assured by a test acc. to DIN 55439.

The packaging consists of environment-friendly, recyclable cardboard. Dispose of the packing material via specialised recycling companies.

Material:

- Packaging of cardboard
- Padding of cardboard or PE foam
  
- Storage and transport temperature, see Supplement, Technical data, Ambient conditions
- Relative humidity 20 ... 85 %

#### Storage and transport temperature

## 4 Mounting

### 4.1 Mounting instructions

#### Select installation position

Select an installation position you can easily reach for mounting and connecting as well as later retrofitting of an indicating and adjustment module PLICSCOM. The housing can be rotated 330° without the use of any tools. You can also mount the adjustment and indicating module PLICSCOM in four different positions (each displaced by 90°).

### 4.2 Mounting procedure

#### Protection against moisture

Protect your VEGAPULS 62 against moisture penetration.

→ Lead the connection cable downward in front of the cable entry

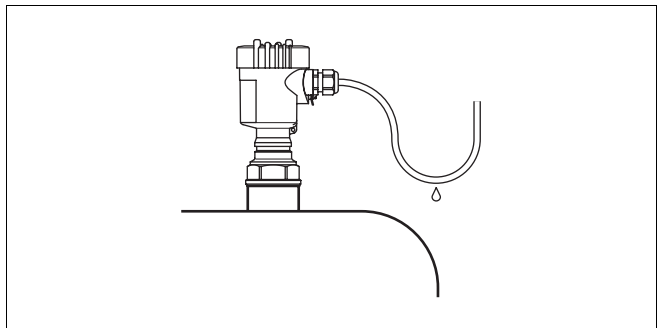

Fig. 2: Measures against moisture penetration

Rain and condensation water can thus drain off. This applies mainly to mounting outdoors, in areas where moisture is expected (e.g. by cleaning processes) or on cooled or heated vessels.

Use cable with round wire cross section and tighten the cable entry.

### 4.3 Mounting examples

#### Measuring range

The reference plane for the sensor measuring range is the lower edge of the flange or the seal surface of the thread.

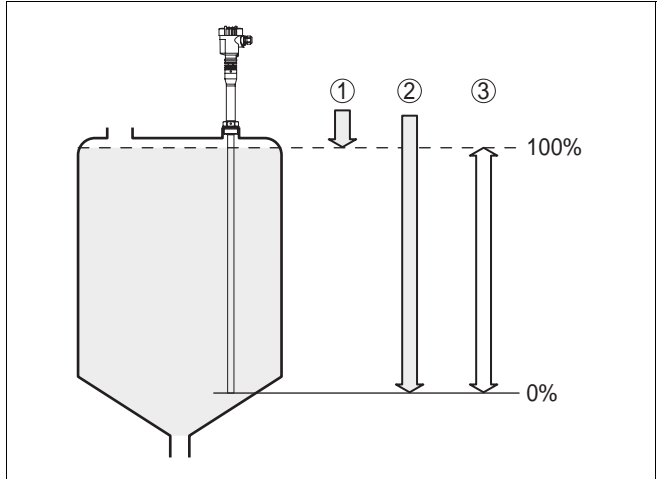

Fig. 3: Measuring range (operating range) and max. measuring distance

- 1 full
- 2 empty
- 3 Measuring range

#### Standpipe antenna

Pipe antennas are preferred in vessels with installations and turbulence such as e.g. heating spirals or stirrers.

The standpipe antenna is also suitable for vessels with foam generation or the measurement of products with low dielectric constants (dielectric value > 1.6)

Standpipe antennas must reach up to the requested min. level as a measurement is only possible in the tube. If a good mixing of the product is important, a radar sensor with perforated surge pipe is recommended.



#### Warning:

Keep in mind that a max. torque of 80 Nm is not exceeded with the 3/4" thread version.

**Turbulence**

In case of turbulence or heavy product movements in the vessel, long standpipe antennas should be fixed on the vessel wall.

**Inflowing material**

Do not mount the instruments in or above the filling stream.

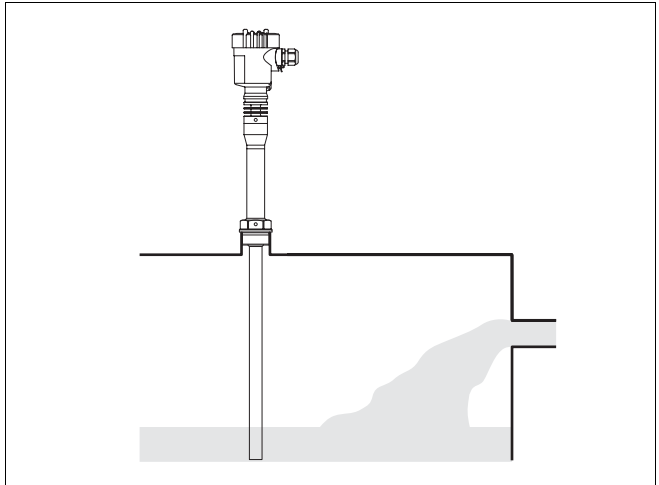

*Fig. 4: Inflowing liquid*

**Adhesive products**

The measurement in a standpipe is not recommended for very adhesive products.

**Pressure**

In case of gauge or low pressure in the vessel you should seal the process fitting on the thread. Check in advance, if the seal material is resistant against the measured product. The max. permissible pressure is stated in the Technical data in the Supplement or on the type label of the sensor.

## 5 Connecting to power supply

### 5.1 Preparing the connection

#### Note safety instructions

Always observe the following safety instructions:

- Connect only in the complete absence of line voltage
- If overvoltages are expected, overvoltage arresters should be installed.



#### Tip:

We recommend VEGA overvoltage arresters ÜS-F-LB-I and ÜSB 62-36G.X.

#### Take note of safety instructions for Ex applications



In hazardous areas you should take note of the appropriate regulations, conformity and type approval certificates of the sensors and power supply units.

#### Select power supply

Power supply and current signal are transmitted via the same two-wire connection cable. The power supply range can differ depending on the instrument version. The exact range is stated in the Technical data in the Supplement.

Provide a reliable separation between the supply circuit and the mains circuits acc. to DIN VDE 0106 part 101.

The VEGA power supply units VEGATRENN 149AEx, VEGASTAB 690, VEGADIS 371 as well as all VEGAMETS meet this requirement. When using one of these instruments, protection class III is ensured for VEGAPULS 62.

Bear in mind the following factors regarding supply voltage:

- the reduction of the output voltage of the power supply unit under nominal load (with a sensor current of 20.5 mA or 22 mA in case of fault signal)
- the influence of additional instruments in the circuit (see load values in Technical data)

**Select connection cable**

VEGAPULS 62 is connected with standard two-wire cable. An outer cable diameter of 5 ... 9 mm ensures the seal effect of the cable entry. If electromagnetic interference is expected, we recommend the use of screened cable.

**Cable screening and grounding**

Connect the cable screen on both ends to ground potential. In the sensor, the screen must be connected directly to the internal ground terminal. The ground terminal on the outside of the housing must be connected to the potential equalisation facility.

If potential equalisation currents are expected, the connection on the evaluation side must be made via a ceramic capacitor (e.g. 1 nF, 1500 V). The low frequency potential equalisation currents are thus suppressed, but the protective effect against high frequency interference signals remains.

**Select connection cable for Ex applications**

Take note of the corresponding installation regulations for Ex applications.

**5.2 Connection procedure**

Proceed as follows:

- 1 Unscrew the housing cover
- 2 If a PLICSCOM indicating and adjustment module is installed, remove it by turning it slightly to the left
- 3 Loosen compression nut of the cable entry
- 4 Remove approx. 10 cm of the cable mantle, strip approx. 1 cm insulation from the ends of the individual wires
- 5 Insert the cable into the sensor through the cable entry
- 6 Lift the opening levers of the terminals with a screwdriver (see following illustration)
- 7 Insert the wire ends into the open terminals according to the wiring plan

- 8 Press down the opening levers of the terminals, you will hear the terminal spring closing
  - 9 Check the hold of the wires in the terminals by lightly pulling on them
  - 10 Connect the screen to the internal ground terminal and the external ground terminal to potential equalisation
  - 11 Tighten the compression nut of the cable entry, the seal ring must completely encircle the cable
  - 12 Screw the housing cover back on
- The electrical connection is finished.



Fig. 5: Connection steps 6 and 7

### 5.3 Wiring plans, single chamber housing with cable entry

#### Overview

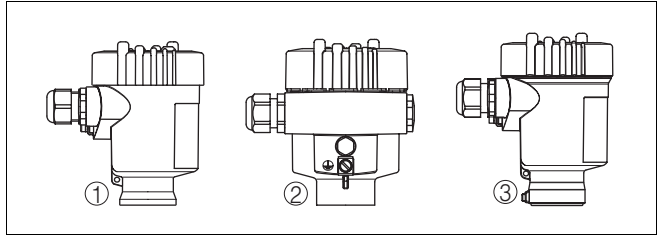

Fig. 6: Overview of the three material versions of the single chamber housing

- 1 Plastic
- 2 Aluminium
- 3 Stainless steel

#### Top view, electronics and connection compartment (non-Ex and Ex ia)

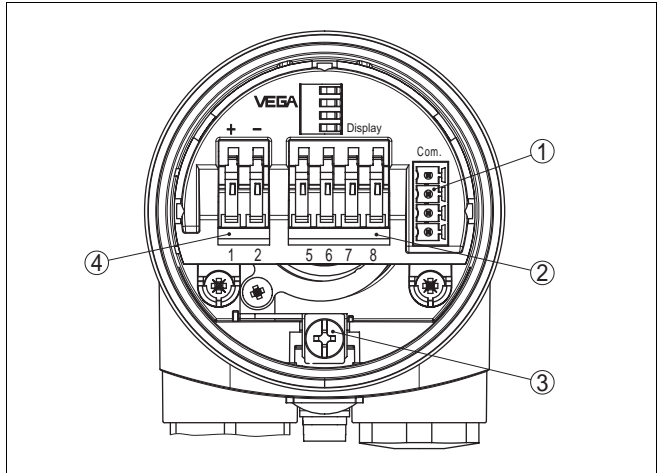

Fig. 7: Top view of the electronics and connection compartment

- 1 Plug connector for VEGACONNECT (I<sup>2</sup>C interface)
- 2 Spring-loaded terminals for connection of the external indication VEGADIS 61
- 3 Ground terminal for connection of the cable screen
- 4 Spring-loaded terminals for power supply (4 ... 20 mA)

**Wiring plan (non-Ex and Ex ia)**

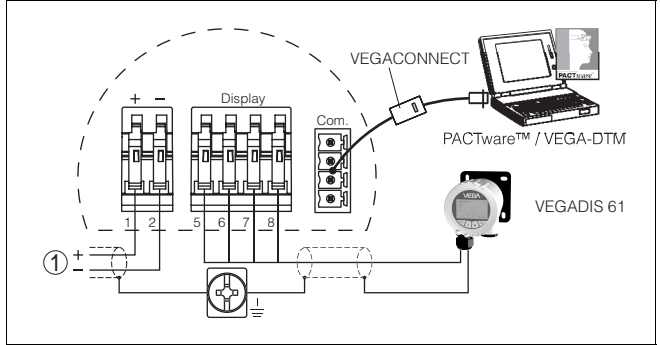

Fig. 8: Wiring plan, single chamber housing

1 4 ... 20 mA connection/power supply

**5.4 Wiring plans, double chamber housing with cable entry**

**Overview**

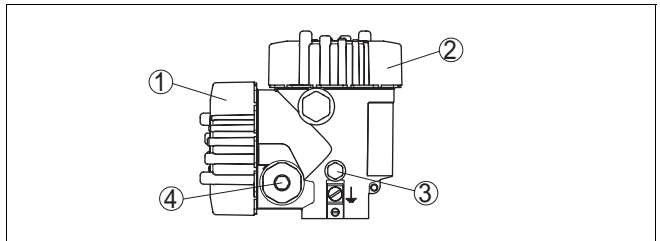

Fig. 9: Double chamber housing, non-Ex instrument, Ex ia and Exd instrument

- 1 Connection compartment
- 2 Electronics compartment
- 3 Breather element
- 4 Cable entry (pressure-tight with Exd)

**Top view, electronics compartment (non-Ex, Ex ia and Exd)**

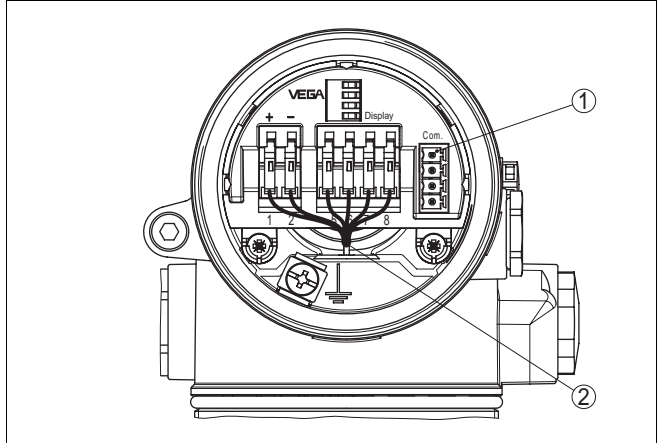

Fig. 10: Top view of the electronics compartment in double chamber housing

- 1 Plug connector for VEGACONNECT (I<sup>2</sup>C interface)
- 2 Internal connection cable to the connection compartment

**Top view, connection compartment (non-Ex and Ex ia)**

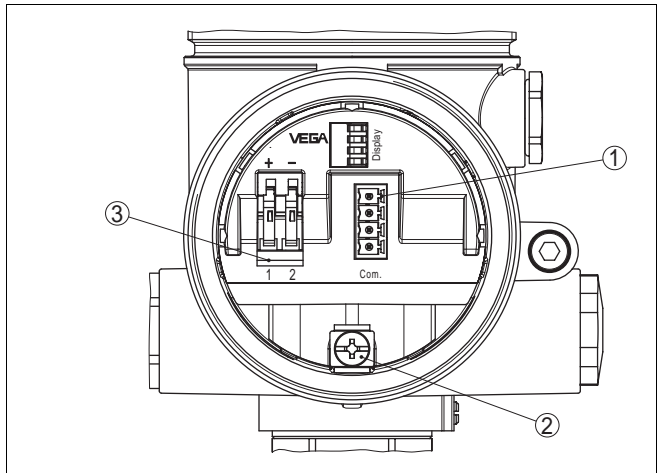

Fig. 11: Connection compartment, double chamber housing

- 1 Plug connector for VEGACONNECT (I<sup>2</sup>C interface)
- 2 Ground terminal for connection of the cable screen
- 3 Spring-loaded terminals for power supply (4 ... 20 mA)

**Wiring plan (non-Ex and Ex ia)**

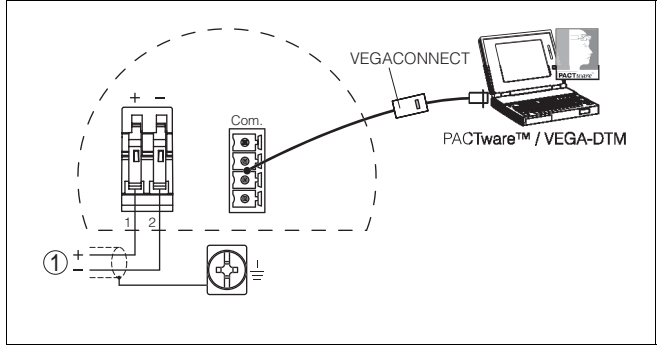

Fig. 12: Wiring plan, double chamber housing

1 4 ... 20 mA connection/power supply

**Top view, connection compartment Exd**

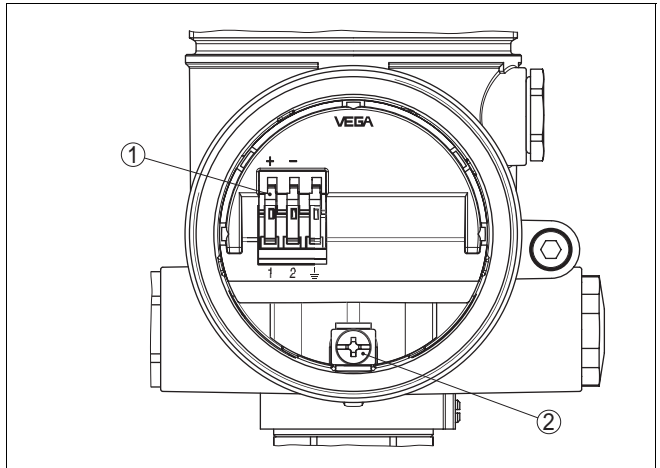

Fig. 13: Connection compartment, double chamber housing Exd

- 1 Spring-loaded terminals for power supply (4 ... 20 mA) and cable screen
- 2 Ground terminal for connection of the cable screen

**Note:**

With Exd, the indicating and adjustment module PLICSCOM may only be used in the electronics compartment.

**Wiring plan, Exd**

Fig. 14: Wiring plan, double chamber housing Exd

1 4 ... 20 mA connection/power supply

## 6 Set-up with the indicating and adjustment module PLICSCOM

### 6.1 Short description

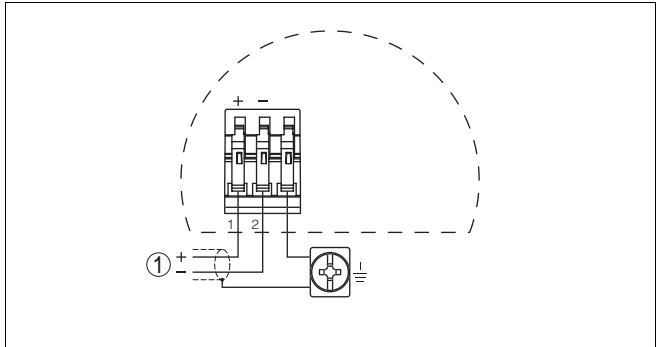
#### Function/Configuration

The indicating and adjustment module PLICSCOM is used for measured value display, adjustment and diagnosis. It can be mounted in the following housing versions and instruments:

- all sensors of the plics® instrument family, in the single as well as in the double chamber housing (optionally in electronics or connection compartment)
- external indicating instrument VEGADIS 61

### 6.2 Installing the indicating and adjustment module PLICSCOM

#### Insert/remove PLICSCOM

PLICSCOM can be inserted or removed at any time. An interruption of the power supply is not necessary.

To install, proceed as follows:

- 1 Unscrew housing cover
- 2 Place PLICSCOM in the desired position on the electronics (you can choose any one of four different positions - each displaced by 90°)
- 3 Press PLICSCOM lightly onto the electronics and turn it to the right until it snaps in
- 4 Screw housing cover with inspection window tightly back on

Removal is carried out in reverse order.

PLICSCOM is powered by the sensor, an additional connection is not necessary.

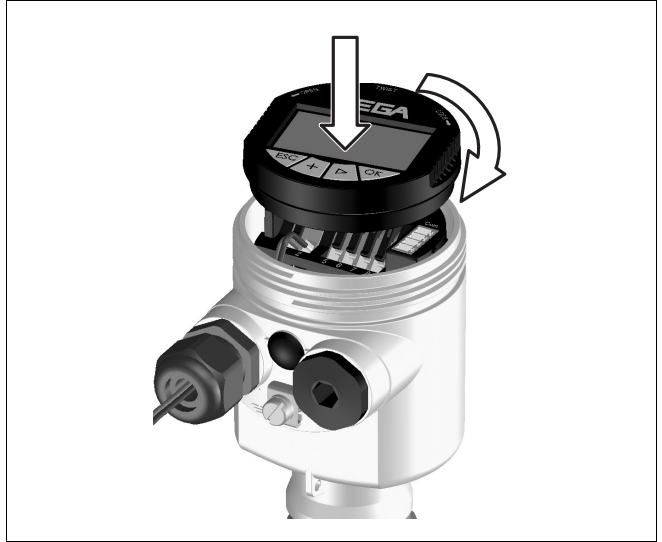

Fig. 15: Installation of PLICSCOM



**Note:**

If you intend to retrofit VEGAPULS 62 with PLICSCOM for continuous measured value indication, a higher cover with an inspection glass is required.

### 6.3 Adjustment system

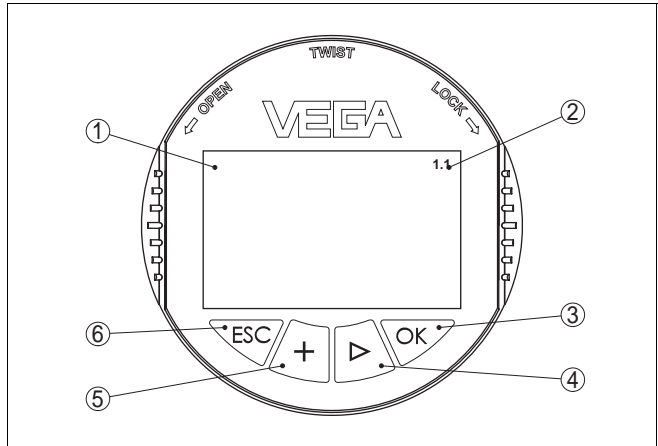

Fig. 16: Indicating and adjustment elements

1 **LC display for indication of:**

- measured value
- menu item
- parameter

2 **Indication of the menu item number**

3 **OK key:**

- move to the menu overview
- confirm selected menu
- edit parameter
- save value

4 **-> key to select:**

- menu change
- list entry
- editing position

5 **+ key:**

- modify value of a parameter

6 **ESC key:**

- interrupt input
- jump to the next higher menu

#### Adjustment system

The sensor is adjusted via the four keys of the indicating and adjustment module PLICSCOM. The LC display indicates the individual menu items. The functions of the individual keys are shown in the above illustration. Approx. 10 minutes after the last pressing of a key, an automatic reset to measured value display is triggered. Any values not confirmed with **OK** will not be saved.

## 6.4 Set-up procedure

### Switching on phase

After VEGAPULS 62 is connected to power supply, the instrument carries out a self-test for approx. one minute. The following steps are carried out:

- internal check of the electronics
- indication of the instrument type, the firmware version as well as the sensor-TAGs (sensor name)
- the output signal jumps briefly to the set fault current (HART sensor), i.e. the status byte changes the fault value (Profibus PA and FF sensors)

Then the actual measured value is displayed and the corresponding current (HART sensor) or the digital output signal is transmitted to the cable (Profibus PA and FF sensors) <sup>1)</sup>.

### Parameter adjustment

Since VEGAPULS 62 is a distance measuring instrument, it measures the distance from itself to the product surface. In order to have the actual level displayed, an allocation of the measured distance to the percentage height must be carried out. To make this adjustment, the full and empty distances in the vessel are entered. If these values are not known, it is also possible to carry out the adjustment with other distances, e.g. 10 % and 90 %. Starting point for these distance values is always the seal surface of the thread or flange. The actual level is then calculated on the basis of these entered values. At the same time, the operating range of the sensor is limited from the maximum range to the requested range.

The real product level during this adjustment is not important, because the min./max. adjustment is always carried out without changing the product level. These settings can be made ahead of time without the instrument having to be installed.

<sup>1)</sup> The values correspond to the actual level as well as to the settings already carried out, e.g. default setting.

In the main menu item "Basic adjustment", the individual submenu items should be selected one after the other and provided with the correct parameter values. This will ensure an optimum adjustment of the measurement.



**Note:**

With HART multidrop and Profibus PA, the address setting should be carried out first. You will find a description of this in the operating instructions manual of PLICSCOM.

Start your parameter adjustment with the menu items of the basic adjustment:

**Carrying out min. adjustment**

Proceed as follows:

- 1 Move from the measured value display to the main menu by pushing **[OK]**.

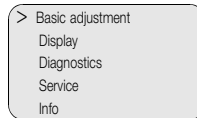

- 2 Select the menu item *Basic adjustment* with **[->]** and confirm with **[OK]**. Now the menu item "Min. adjustment" is displayed.

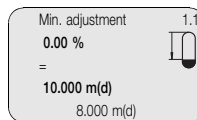

- 3 Prepare the percentage value for editing with **[OK]** and set the cursor to the requested position with **[->]**. Enter the requested % value with **[+]** and save with **[OK]**. The cursor jumps now to the distance value.
- 4 Enter the appropriate distance value in m/f (corresponding to the percentage value) for the empty vessel (e.g. distance from the sensor to the vessel bottom).
- 5 Save the settings with **[OK]** and move to max. adjustment with **[->]**.

**Carrying out max. adjustment**

Proceed as follows:

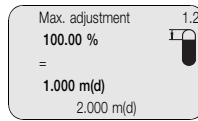

- 1 Prepare the percentage value for editing with **[OK]** and set the cursor to the requested position with **[->]**. Set the requested % value with **[+]** and save with **[OK]**. The cursor jumps now to the distance value.
- 2 Enter the appropriate distance value in m/ft (corresponding to the percentage value) for the full vessel. Please remember that the max. level must be below the radar antenna.
- 3 Save the settings with **[OK]** and move to medium selection with **[->]**.

**Medium selection**

Each medium has different reflection characteristics.

Liquids have different reflection characteristics depending on their conductivity and dielectric constant. For this reason there are different options under the menu item Liquid such as *Solvents*, *Chemical mixtures* and *Water based*.

Through this additional selection, the sensor is adapted to the product and its reliability, particularly when the product has poor reflective properties, is considerably increased.

Enter the requested parameters via the appropriate keys, save your settings and jump to the next menu item with the **[->]** key.

**Damping**

To suppress fluctuations in the measured value display, e. g. by agitated product surfaces, an integration time can be set. This time can be between 0 and 999 seconds. Please note that the reaction time of the entire measurement will be longer and the sensor will react to quick changes of the measured value with a corresponding delay. In general, a time of a few seconds is sufficient to smooth the measured value display.

Enter the requested parameters via the appropriate keys, save your settings and jump to the next menu item with the **[→]** key.

### **Linearisation curve**

A linearisation is necessary for all vessels in which the vessel volume does not increase linearly with the level, e.g. in a cylindrical tank or spherical tank - and the indication and output of the volume is requested. Corresponding linearisation curves are preprogrammed for these vessels. They represent the correlation between level percentage and vessel volume. By activating the appropriate curve, the volume percentage of the vessel is displayed correctly. If the volume should not be displayed in percent, but e.g. in l or kg, it is possible to set a scaling in the menu item "Display".

Enter the requested parameters via the appropriate keys, save your settings and jump to the next menu item with the **[→]** key.

### **Sensor-TAG**

In this menu item you can enter a clear designation for the sensor, e.g. the measurement loop name or the tank or product designation. In digital systems and in the documentation of larger plants, a unique designation should be entered for exact identification of individual measuring sites.

With this menu item the basic adjustment is finished and you can now return to the main menu with the **[ESC]** key.

### **Additional settings**

Additional adjustment and diagnosis options such as e.g. scaling, simulation or echo curve presentation are shown in the following menu schematic. You will find a detailed description of these menu items in the operating instructions manual of the indicating and adjustment module PLICSCOM.

## 6.5 Menu schematic

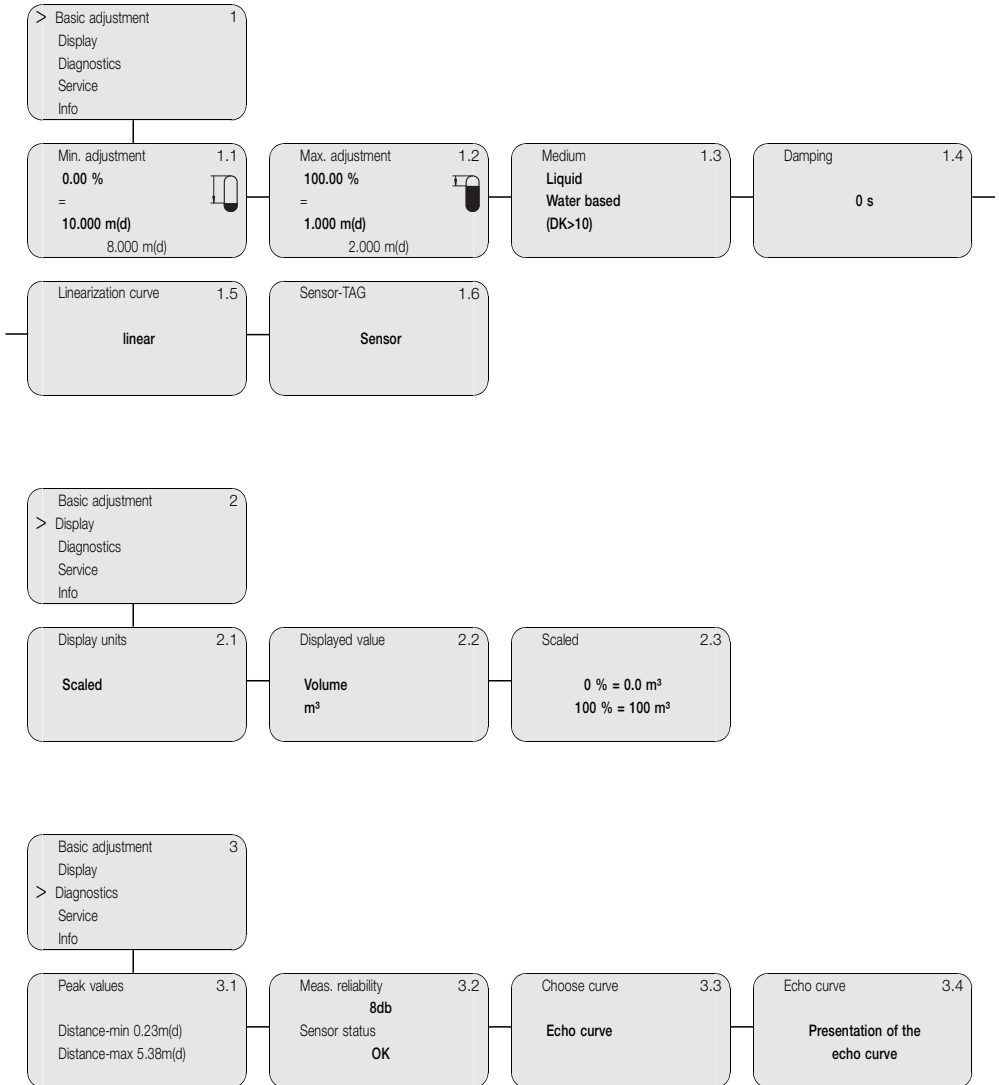

Basic adjustment 3  
 Display  
 > Diagnostics  
 Service  
 Info

Peak values 3.1  
 Distance-min: 0.234m(d)  
 Distance-max: 5.385m(d)

Meas. reliability 3.2  
**8db**  
 Sensor status  
**OK**

Choose curve 3.3  
**Echo curve**

Echo curve 3.4  
**Presentation of echo curve**

Basic adjustment 4  
 Display  
 Diagnostics  
 > Service  
 Info

False echo memory 4.1  
 Change?

Addl. adjustments 4.2  
**none**

Current output 4.3  
 Output mode 4-20 mA  
 Failure mode <3.6 mA  
 Min. current 3.8 mA

Simulation 4.4  
**Start simulation?**

Sensor length 4.5  
**5 m(d)**

Reset 4.6  
**Select reset?**

Units of measurement 4.7  
**m(d)**  
**Select?**

Language 4.8  
**Deutsch**

HART operation mode 4.9  
**Standard**  
**Address 0**

Copy sensor data 4.10  
**Copy sensor data?**

PIN 4.11  
**Enable?**

Basic adjustment 5  
 Display  
 Diagnostics  
 Service  
 > Info

Sensor type 5.1  
 VEGAPULS 6x  
 Serial number  
 12345678

Date of manufacture 5.2  
 29. April 2003  
 Software version  
 2.01.00

Date of last change 5.3  
 using PC  
**15. May 2003**

Sensor details 5.4  
**Display now**

## 7 Set-up with PACTware™

### 7.1 Connecting the PC

#### Connecting the PC directly to the sensor

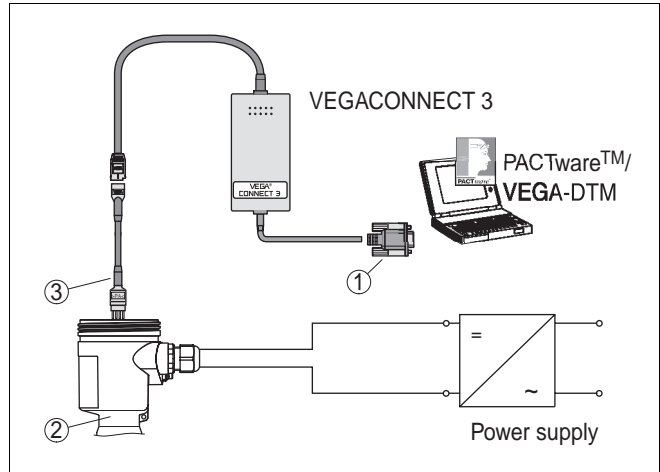

Fig. 17: PC connected directly to the sensor

- 1 RS232 connection
- 2 VEGAPULS 62
- 3 I²C adapter cable for VEGACONNECT 3
- 4 I²C bus plug

#### Necessary components:

- VEGAPULS 62
- PC with PACTware™ and suitable VEGA-DTM
- VEGACONNECT 3 with I²C adapter cable (article no. 2.27323)
- power supply unit

**Tip:**

Further set-up steps are described in the operating instructions manual *DTM Collection/PACTware* attached to each CD and which can be downloaded from our homepage. A detailed description is available in the online help of PACTware™ and the VEGA-DTMs.

### Connecting the PC to the signal cable

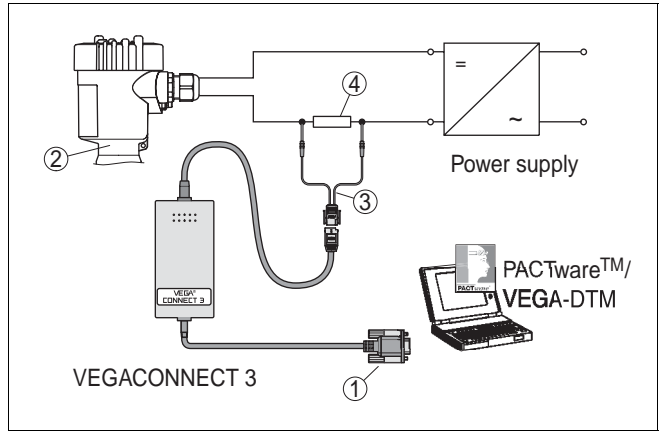

Fig. 18: PC connected to the signal cable

- 1 RS232 connection
- 2 VEGAPULS 62
- 3 VEGACONNECT 3 adapter cable for HART
- 4 HART resistance 250 Ohm

#### Necessary components:

- VEGAPULS 62
- PC with PACTware™ and suitable VEGA-DTM
- VEGACONNECT 3 with adapter cable for HART
- HART resistance 250 Ohm
- power supply unit

**Note:**

With power supply units with integrated HART resistance, an additional external resistance is no longer necessary. In such cases, VEGACONNECT 3 can be connected in parallel to the power supply.

## 8 Maintenance and fault rectification

### 8.1 Maintenance

In normal operation with appropriate use, VEGAPULS 62 is completely maintenance-free.

### 8.2 Fault rectification

#### Checking the 4 ... 20 mA signal

Connect a hand-held multimeter with a suitable measuring range acc. to the wiring plan.

#### ? 4 ... 20 mA signal not stable

- level fluctuations

→ set integration time via PLICSCOM or PACTware™

#### ? 4 ... 20 mA signal missing

- incorrect connection to power supply

→ check connection acc. to chapter "Connection procedure" and correct, if necessary, acc. to chapter "Wiring plans"

- no power supply

→ check cables for line break, repair, if necessary

- power supply too low or load resistance too high

→ check and adapt, if necessary

#### ? Current signal more than 22 mA or less than 3.6 mA

- electronics module defective

→ exchange instrument or return for repair

**Fault messages via  
PLICSCOM**

In Ex applications, regulations for the wiring of intrinsically safe circuits must be observed.

**? E013**

- no measured value available
- sensor in boot phase
- sensor does not find an echo, e.g. through incorrect installation or wrong parameter adjustment

**? E017**

- adjustment span too small
- carry out a fresh adjustment and increase the distance between min. and max. settings

**? E036**

- no operable sensor software
- carry out a software update or return instrument for repair

**? E042/E043**

- Hardware error, electronics defective
- exchange instrument or return for repair

### 8.3 Repairing the instrument

If it is necessary to repair VEGAPULS 62, please send the instrument to the following address:

VEGA Grieshaber KG; Repair department; Am Hohenstein 113; 77761 Schiltach/Germany

## 9 Dismounting

### 9.1 Dismounting procedure

Take note of chapters "Mounting" and "Connecting to power supply" and carry out the listed steps in reverse order.

### 9.2 Disposal

VEGAPULS 62 consists of materials which can be recycled by specialised recycling companies. We have purposely designed the electronic modules to be easily separable. Mark the instrument as scrap and dispose of it according to government regulations (electronic scrap ordinance, etc. ...).

Materials: see Technical data

If you cannot dispose of the instrument properly, please contact us about disposal methods or return.

## 10 Supplement

### 10.1 Technical data

#### General data

---

##### Materials, wetted parts

- process fitting thread G $\frac{3}{4}$ A,  $\frac{3}{4}$  NPT, G1 $\frac{1}{2}$ A and 1 $\frac{1}{2}$  NPT, flanges DN 40 ... DN 150 and 1 $\frac{1}{2}$ " ... 6": stainless steel 1.4435
- antenna PTFE (TFM1600)
- seal antenna system Viton, Kalrez 6375
- standpipe stainless steel 1.4435

##### Materials, non-wetted parts

- housing plastic PBT (Polyester), Alu-die casting powder-coated, stainless steel 1.4435
- seal ring between housing and housing cover NBR (stainless steel housing), silicone (Alu/plastic housing)
- inspection window in housing cover for PLICSCOM Polycarbonate
- ground terminal stainless steel 1.4571/1.4435

##### Weight

- process fitting, thread 2.0 ... 2.8 kg (depending on thread size and housing material)
- process fitting, flange 4.2 ... 15.4 kg (depending on flange size and housing material)
- standpipe 1.6 kg/m

##### Standpipe length

up to 4 m

---

## Output variable

Output signal	4 ... 20 mA/HART
Resolution	1.6 $\mu$ A
Fault signal	current output unchanged, 20.5 mA, 22 mA, < 3.6 mA (adjustable)
Current limitation	22 mA
Load	
– 4-wire sensor	max. 500 Ohm <sup>2)</sup>
– 2-wire sensor	see load diagram in Power supply
Integration time (63% of the input variable)	0 ... 999 s, adjustable
Rise time	150 ms (ti : 0 s, 0 ... 100 %)
Fulfilled Namur recommendation	NE 43

## Input variable

Parameter	distance between process fitting (seal surface hexagon or lower side of flange) of the sensor and product surface
Min. distance	0 mm
Meas. range	up to 4 m

## Accuracy (similar to DIN V 19259-1 and IEC 60770-1)

Reference conditions acc. to IEC 60770-1	
– temperature	18 ... 30°C
– relative humidity	45 ... 75 %
– pressure	860 ... 1060 mbar (86 ... 106 kPa)
Determination of characteristics	limit point adjustment acc. to DIN 16086
Characteristics	linear

<sup>2)</sup> with inductive load, ohmic share at least 25 Ohm/mH

**Characteristic curve deviation and measurement characteristics<sup>3)</sup>**

Temperature error	0.06 %/10 K
Resolution, general	max. 1 mm
Frequency	K-band (26 GHz technology)
Interval	approx. 1 s
Adjustment time <sup>4)</sup>	> 1 s (depending on the parameter adjustment)
Max. emitted power	< 25 mW EIRP <sup>5)</sup>
Received average emitted power reaching an object directly in front of the antenna	
– distance 1 m	0.4 ... 3.2 nW per cm <sup>2</sup> (0.4 ... 3.2 x 10 <sup>-9</sup> W/cm <sup>2</sup> )
– distance 5 m	0.02 ... 0.13 nW per cm <sup>2</sup> (0.02 ... 0.13 x 10 <sup>-9</sup> W/cm <sup>2</sup> )
Accuracy	see diagram

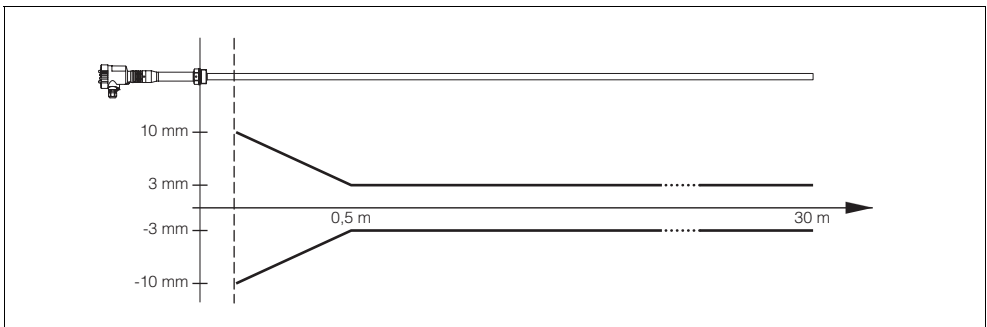

Fig. 19: Accuracy VEGAPULS 62

<sup>3)</sup> In relation to the nominal range, incl. hysteresis and repeatability, determined acc. to the limit point method.  
<sup>4)</sup> Time to output the correct level (with max. 10 % deviation) after a sudden level change.  
<sup>5)</sup> EIRP: Equivalent isotropically radiated power

## Ambient conditions

---

Ambient, storage and transport temperature

- without PLICSCOM -40 ... +80°C
  - with PLICSCOM -40 ... +70°C
- 

## Process conditions

---

Vessel pressure -100 ... 4000 kPa (-1 ... 40 bar) at PN 40

Process temperature (flange temperature)  
depending of the seal of the antenna  
system

- Viton with temperature adapter -40 ... +200°C
- Kalrez 2035, 6230 (FDA) and 6375  
with temperature adapter -15 ... +200°C

Vibration resistance mechanical vibrations with 1 g and  
5 ... 100 Hz <sup>6)</sup>

---

<sup>6)</sup> Tested acc. to the reg. of the German Lloyd, GL-directive 2

## Electromechanical data

---

Cable entry/plug (depending on the version)

- single chamber housing
  - 1 x cable entry M20x1.5 (cable- $\varnothing$  5 ... 9 mm), 1 x blind stopper M20x1.5
  - or:
  - 1 x closing cap  $\frac{1}{2}$  NPT, 1 x blind stopper  $\frac{1}{2}$  NPT
  - or:
  - 1 x plug M12x1, 1 x blind stopper M20x1.5
- double chamber housing
  - 1 x cable entry M20x1.5 (cable- $\varnothing$  5 ... 9 mm), 1 x blind stopper M20x1.5
  - or:
  - 1 x closing cap  $\frac{1}{2}$  NPT, 1 x blind stopper  $\frac{1}{2}$  NPT
  - or:
  - 1 x plug M12x1, 1 x blind stopper M20x1.5

Spring-loaded terminals

for wire cross sections up to 2.5 mm<sup>2</sup>

---

## Indicating and adjustment module PLICSCOM

---

Power supply and data transmission	through sensor via gold-plated sliding contacts (I <sup>2</sup> C bus)
Display	LC display in full dot matrix
Adjustment elements	4 keys
Protection	IP 20 (mounted into sensor without cover: IP 40)
Materials	
– housing	ABS
– inspection window	Polyester foil

---

## Power supply

### Power supply

– non-Ex instrument	14 ... 36 V DC
– EEx ia instrument	14 ... 30 V DC
– Exd instrument	20 ... 36 V DC

### Permissible residual ripple

– < 100 Hz	$U_{ss} < 1 \text{ V}$
– 100 Hz ... 10 kHz	$U_{ss} < 10 \text{ mV}$

Load see diagram

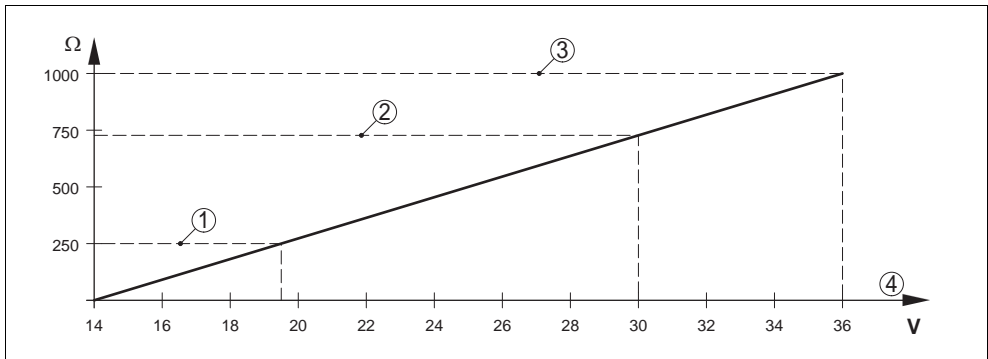

Fig. 20: Voltage diagram

- 1 HART load
- 2 Voltage limit EEx ia instrument
- 3 Voltage limit non-Ex instrument/Exd instrument
- 4 Supply voltage

## Electrical protective measures

Protection	IP 66/IP 67
Overvoltage category	III
Protection class	II

**Approvals <sup>7)</sup>**

---

ATEX II 1G, 1/2G, 2G EEx ia IIC T6,  
ATEX II 1/2G, 2G EEx d ia IIC T6, WHG,  
ship approvals

---

<sup>7)</sup> Deviating data with Ex applications: see separate safety instructions

## 10.2 Dimensions

### Housing

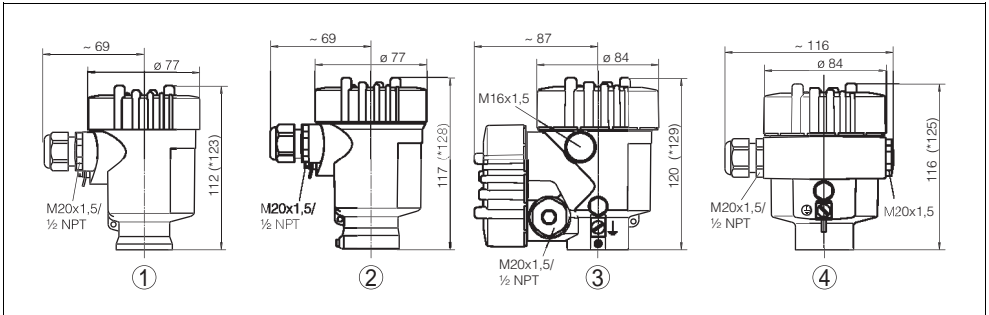

Fig. 21: Housing versions

- 1 Plastic housing (\* dimension with integrated PLICSCOM)
- 2 Stainless steel housing (\* dimension with integrated PLICSCOM)
- 3 Aluminium double chamber housing (\* dimension with integrated PLICSCOM)
- 4 Aluminium housing (\* dimension with integrated PLICSCOM)

**VEGAPULS 62**

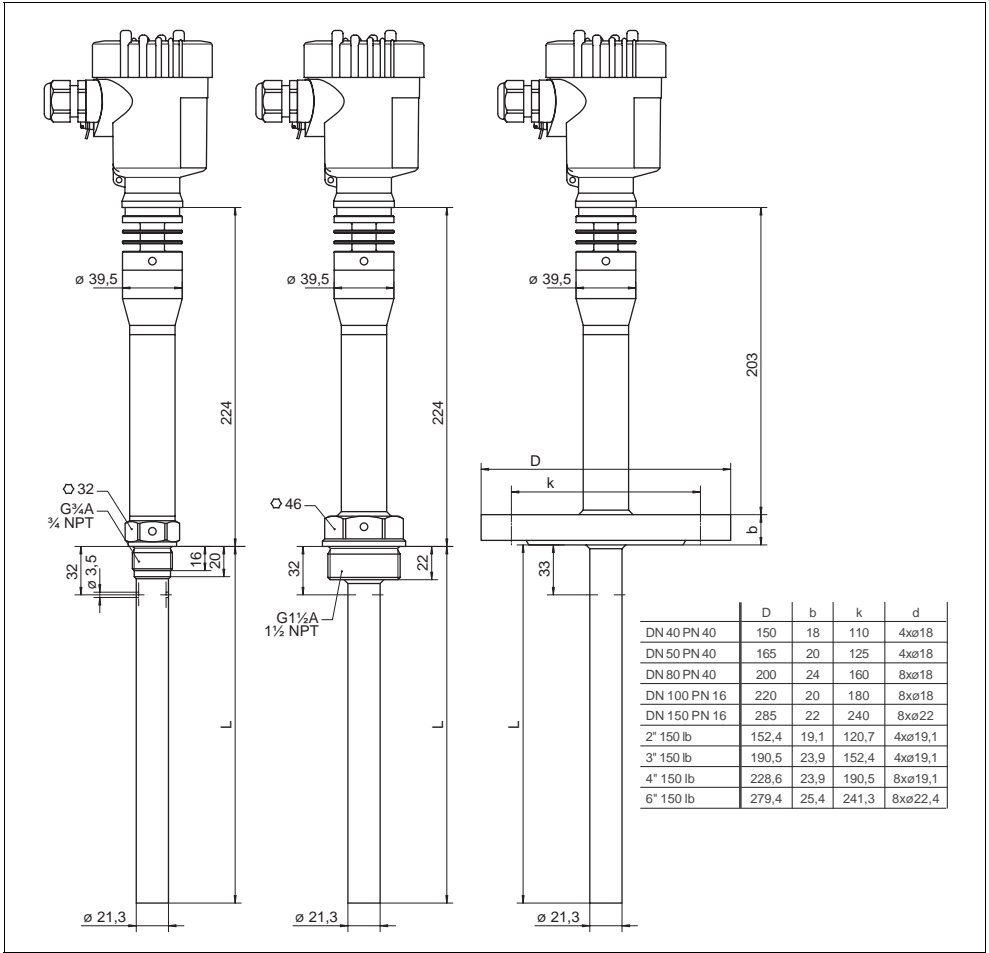

Fig. 22: VEGAPULS 62 in thread and flange version

**10.3 Certificate****CE conformity declaration**



**Konformitätserklärung**

**Declaration of conformity**  
**Déclaration de conformité**



**VEGA Grieshaber KG**  
**Am Hohenstein 113**  
**77761 Schiltach**

erklärt in alleiniger Verantwortung, daß das Produkt / declare under  
our sole responsibility that our product / déclare sous sa seule  
responsabilité que le produit

**VEGAPULS 61, VEGAPULS 62, VEGAPULS 63**  
**VEGAPULS 65, VEGAPULS 66**  
**mit 2Leiter HART-Netzteil**

auf das sich diese Erklärung bezieht, mit den folgenden Normen  
übereinstimmt / to which this declaration relates is in conformity  
with the following standards / auquel se réfère cette déclaration  
est conforme aux normes

EN 61326 : 1997 (Klasse B)  
EN 61326 : 1997 / A1 : 1998  
EN 61010 – 1 : 2001

gemäß den Bestimmungen der Richtlinien / following the provision  
of Directives / conformément aux dispositions des Directives

73/23 EWG  
89/336 EWG  
93/68 EWG

Schiltach, 27.06.2003 *ppa. J. Fehrenbach*

Josef Fehrenbach  
Entwicklungsleitung

Fig. 23: CE conformity declaration

