

Operating Instructions

VEGAPULS 61

4 ... 20 mA/HART - Four-wire

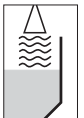

Contents

1 About this document

1.1	Function	4
1.2	Target group	4
1.3	Symbolism used	4

2 For your safety

2.1	Authorised personnel	6
2.2	Appropriate use	6
2.3	Warning about misuse	6
2.4	General safety instructions	6
2.5	CE conformity	7
2.6	Safety information for Ex areas	7
2.7	Environmental instructions	7

3 Product description

3.1	Configuration	8
3.2	Principle of operation	9
3.3	Adjustment	9
3.4	Storage and transport	10

4 Mounting

4.1	Mounting instructions	11
4.2	Mounting procedure	11
4.3	Mounting examples	12

5 Connecting to power supply

5.1	Preparing the connection	20
5.2	Connection procedure	21
5.3	Wiring plans, double chamber housing	23

6 Set-up with the indicating and adjustment module PLICSCOM

6.1	Short description	25
6.2	Installing the indicating and adjustment module PLICSCOM	25
6.3	Adjustment system	27
6.4	Set-up procedure	28

6.5	Menu schematic	33
7	Set-up with PACTware™	
7.1	Connecting the PC	36
8	Maintenance and fault rectification	
8.1	Maintenance	38
8.2	Fault rectification	38
8.3	Repairing the instrument	39
9	Dismounting	
9.1	Dismounting procedure	40
9.2	Disposal	40
10	Supplement	
10.1	Technical Data	41
10.2	Dimensions	47

1 About this document

1.1 Function

This operating instructions manual has all the information you need for quick set-up and safe operation of VEGAPULS 61 . Please read this manual before you start set-up.

1.2 Target group

This operating instructions manual is directed to trained personnel. The contents of this manual should be made available to these personnel and put into practice by them.

1.3 Symbolism used



Information, tip, note

This symbol indicates helpful additional information.



Caution, warning, danger

This symbol informs you of a dangerous situation that could occur. Ignoring this cautionary note can impair the person and/or the instrument.



Ex applications

This symbol indicates special instructions for Ex applications.



List

The dot set in front indicates a list with no implied sequence.



Action

This arrow indicates a single action.

1 **Sequence**

Numbers set in front indicate successive steps in a procedure.

2 For your safety

2.1 Authorised personnel

All operations described in this operating instructions manual must be carried out only by trained and authorised specialist personnel. For safety and warranty reasons, any internal work on the instruments must be carried out only by VEGA personnel.

2.2 Appropriate use

VEGAPULS 61 is a sensor for continuous level measurement.

2.3 Warning about misuse

Inappropriate or incorrect use of the instrument can give rise to application-specific hazards, e.g. vessel overfill or damage to system components through incorrect mounting or setting.

2.4 General safety instructions

VEGAPULS 61 is a high-tech instrument requiring the strict observance of standard regulations and guidelines. Depending on the instrument version, the emitting frequencies of all VEGAPULS sensors are in the C or K band range. The exact emitting frequency is stated in the Technical data in the Supplement. Due to the low emitted power, which is far below the internationally approved limit values, there are no hazards to health if the instrument is used correctly. The instrument may also be used without restriction on the outside of closed metal vessels. The user must take note of the safety instructions in this operating instructions manual, the country-specific installation standards (e.g. the VDE regulations in Germany) as well as all prevailing safety regulations and accident prevention rules.

2.5 CE conformity

VEGAPULS 61 is in CE conformity with EMC (89/336/EWG), R & TTE (1999/5/EC), fulfils the Namur recommendation NE 21 and is in CE conformity with NSR (73/23/EWG).

Conformity has been judged acc. to the following standards:

- EMC:
 - Emission EN 61326: 1997 (class B)
 - Susceptibility EN 61326: 1997/A1: 1998
- R & TTE: I-ETS 300-440 Expert opinion No. 0043052-02/SEE, Notified Body No. 0499
- NSR: EN 61010-1: 2001.

2.6 Safety information for Ex areas

Please note the Ex specific safety information for installation and operation in Ex areas. These safety instructions are part of the operating instructions manual and come with the Ex approved instruments.

2.7 Environmental instructions

Protection of the environment is one of our most important duties. That is why we have introduced an environment management system with the goal of continuously improving company environmental protection. The environment management system is certified acc. to DIN EN ISO 14001.

Please help us fulfil this obligation by observing the environmental instructions in this manual:

- Chapter "Storage and transport"
- Chapter "Disposal"

3 Product description

3.1 Configuration

Scope of delivery

The scope of delivery encompasses:

- VEGAPULS 61 radar sensor
- documentation
 - this operating instructions manual
 - Ex-specific safety instructions (with Ex versions) and, if necessary, further certificates.

Components

VEGAPULS 61 consists of the following components:

- process connection with encapsulated antenna system
- housing with electronics
- Housing cover, optional with indicating/adjustment module PLICSCOM

The components are available in different versions.

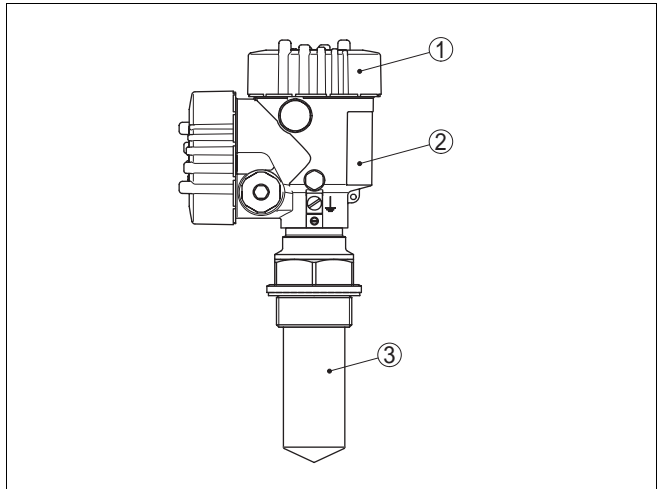

Fig. 1: VEGAPULS 61 , screwed version with Alu double chamber housing

- 1 Housing cover with integrated PLICSCOM (optional)
- 2 Housing with electronics
- 3 Proconnection with encapsulated antenna system

3.2 Principle of operation

Area of application

VEGAPULS 61 is a radar sensor in K-band technology (emitting frequency approx. 26 GHz) for continuous level measurement. It is particularly suitable for measurement under facile process conditions in small vessels containing corrosive liquids.

Physical principle

The antenna of the radar sensor emits short radar pulses with a duration of approx. 1 ns. These radar pulses are reflected by the product and received by the antenna as echoes. The running time of the radar pulses from emission to reception is proportional to the distance and hence to the level. The determined level is converted into an appropriate output signal and outputted as measured value.

Power supply

Four-wire electronics with separate power supply.

The power supply range can differ depending on the instrument version. The exact range is stated in the Technical data in the Supplement.

The measured value transmission is carried out via 4 ... 20 mA/HART output separated from the power supply.

3.3 Adjustment

VEGAPULS 61 can be adjusted with three different media:

- with the indicating and adjustment module PLICSCOM
- with the adjustment software acc. to FDT/DTM standard, e.g. PACTware™ and PC
- with a HART handheld

The entered parameters are generally saved in VEGAPULS 61, when adjusting with PACTware™ and PC, also optionally in the PC.

3.4 Storage and transport

Packaging

Your instrument was protected by packaging during transport. Its capacity to handle normal loads during transport is assured by a test acc. to DIN 55439.

The packaging consists of environment-friendly, recyclable cardboard. Dispose of the packing material via specialised recycling companies.

Storage and transport temperature

- Storage and transport temperature, see Supplement, Technical data, Ambient conditions
- Relative humidity 20 ... 85 %

4 Mounting

4.1 Mounting instructions

Select installation position

Select an installation position you can easily reach for mounting and connecting as well as later retrofitting of an indicating and adjustment module PLICSCOM. The housing can be rotated 330° without the use of any tools. You can also mount the adjustment and indicating module PLICSCOM in four different positions (each displaced by 90°).

4.2 Mounting procedure

Protection against moisture

Protect your VEGAPULS 61 against moisture penetration.

- Lead the connection cable downward in front of the cable entry

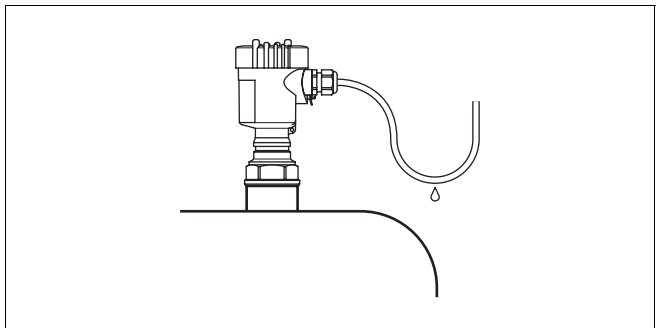

Fig. 2: Measures against moisture penetration

Rain and condensation water can thus drain off. This applies mainly to mounting outdoors, in areas where moisture is expected (e.g. by cleaning processes) or on cooled or heated vessels.

Use cable with round wire-cross section and tighten the cable entry.

4.3 Mounting examples

Measuring range

The reference plane for the measuring range of the sensors is the seal surface of the thread.



Information:

Keep in mind that in measuring environments where the medium can reach the antenna, buildup can form on the antenna, possibly causing measurement errors.

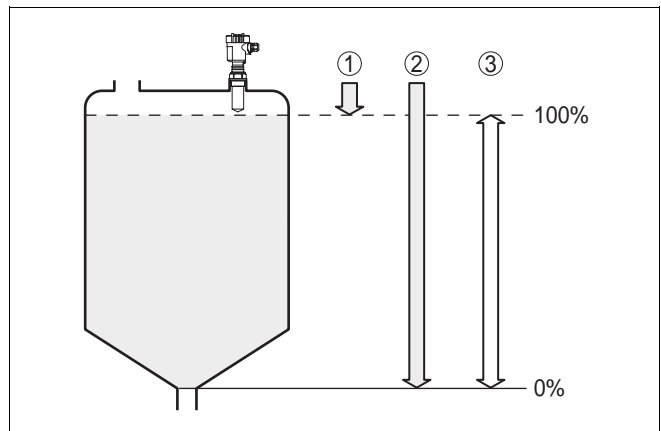

Fig. 3: Measuring range (operating range) and max. measuring distance

- 1 full
- 2 empty (max. measuring distance)
- 3 Measuring range

Installation position

When mounting VEGAPULS 61 keep a distance of at least 200 mm to the vessel wall. If the sensor is installed in the center of dished or arched tank tops, multiple echoes can arise. These can, however, be faded out by an appropriate adjustment (see Set-up).

If this distance cannot be complied with, a false echo storage should be carried out during set-up. This applies particularly if buildup on the vessel wall is expected. In this case, we recommend repeating the false echo storage later on with existing buildup.

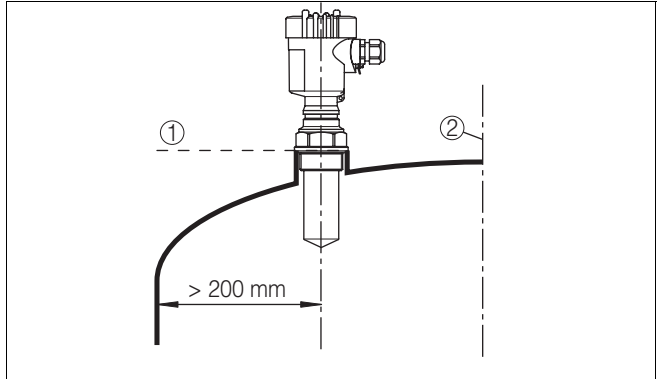

Fig. 4: Mounting on arched vessel tops

- 1 Reference plane
- 2 Vessel center or symmetry axis

In vessels with conical vessel bottom it can be advantageous to mount the sensor in the vessel center, as measurement is then possible right down to the lowest point of the vessel bottom.

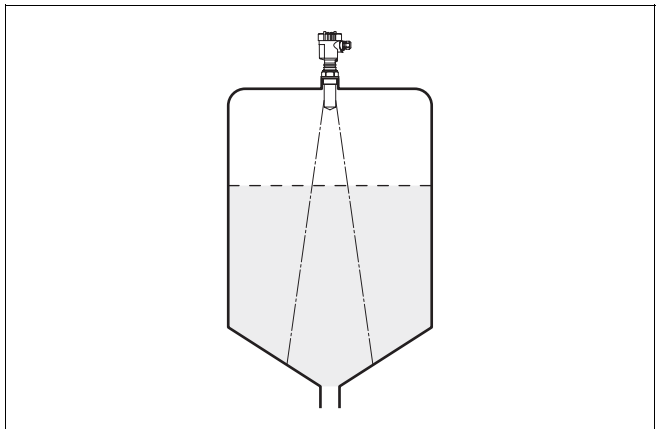

Fig. 5: Vessel with conical bottom

Socket

Preferrably the socket piece should be dimensioned so that the antenna end protrudes at least 10 mm out of the socket.

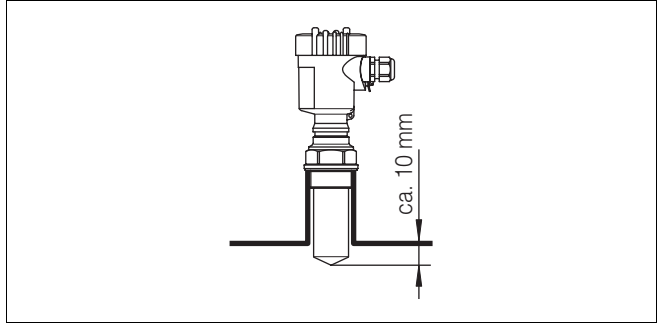

Fig. 6: Recommended socket mounting

If the product has good reflective properties, VEGAPULS 61 can be also mounted on socket pieces being higher than the antenna length. Standard values of socket heights are shown in the following illustration. In this case, the socket end should be smooth and burr-free, if possible rounded. Afterwards you must carry out a false echo storage.

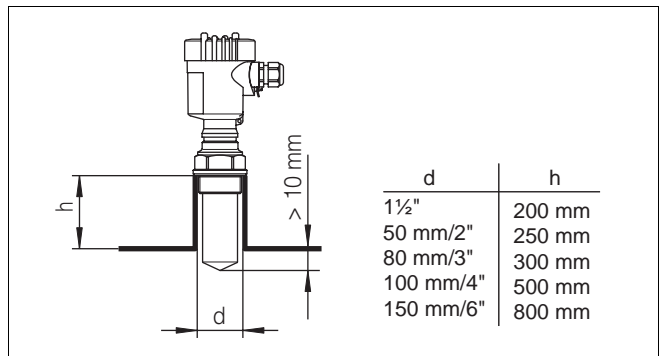

Fig. 7: Deviating socket dimensions

Inflowing material

Do not mount the instruments in or above the filling stream. Ensure that you detect the product surface and not the inflowing material.

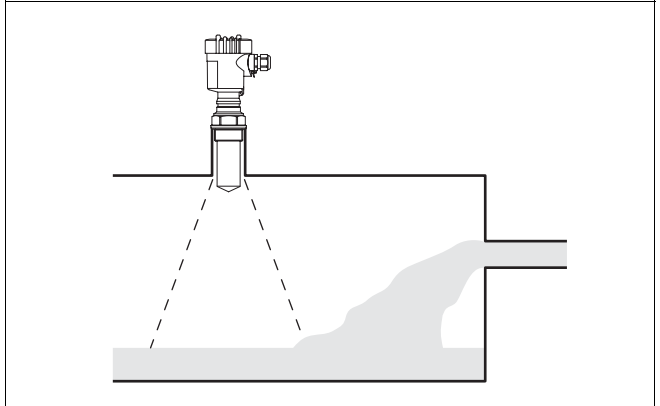

Fig. 8: Inflowing liquid

Sensor orientation

When applied to liquids, the sensor should be mounted as vertical as possible to the medium surface to achieve optimum measuring results.

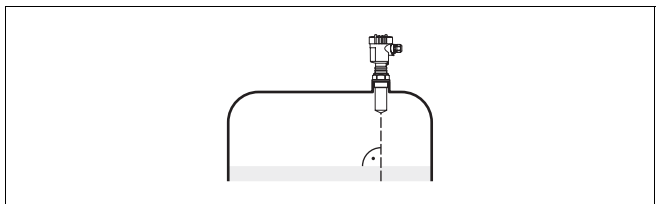

Fig. 9: Orientation in liquids

Vessel installations

The installation location of the radar sensor must be selected such that no installations cross the radar signals.

Vessel installations such as, for example, ladders, level switches, heating spirals, struts etc. can cause false echoes superimposed on the useful echo. When planning your measuring site, make sure that the radar signals have free access to the measured product.

In case of existing vessel installations, a false echo storage should be carried out during set-up.

If large vessel installations such as struts and supports cause false echoes, these can be attenuated by applying supplementary measures. Small, inclined sheets above the installations scatter the radar signals and avoid a direct false echo reflection.

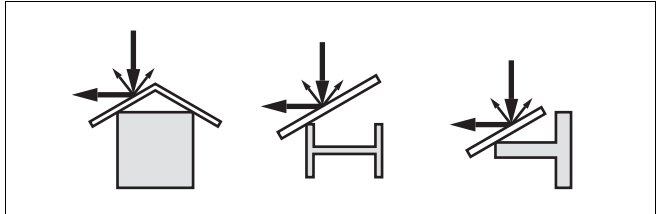

Fig. 10: Cover smooth profiles with deflectors

Stirrers

If there are stirrers in the vessel, the false echo storage should be carried out when the stirrers are in motion. This ensures that interfering reflections from the stirrer are saved with the stirrer in different positions.

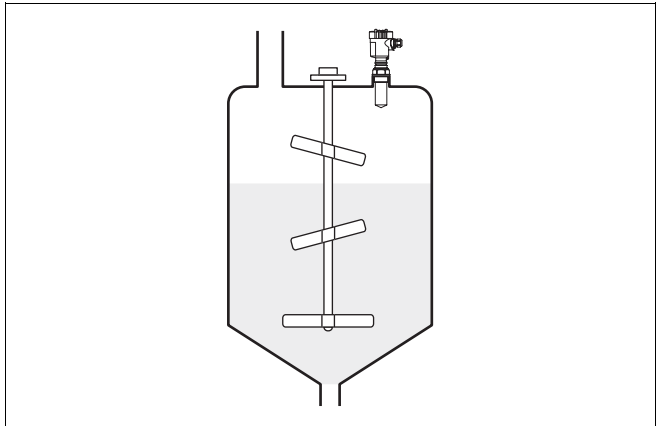

Fig. 11: Stirrers

Foam generation

Through filling, stirring and other processes in the vessel, dense foams which considerably dampen the emitted signal can form on the product surface.

If foams are causing measurement errors, the largest possible radar antennas in combination with low frequency radar sensors, e.g. VEGAPULS 65/66 (C-band), should be used.

VEGAFLEX sensors with guided microwaves are unaffected by foam generation and are particularly suitable for such applications.

Measurement in a standpipe (surge or bypass tube)

By mounting in a standpipe, the negative influence of installations and turbulence are completely avoided. Given this prerequisite, measurement of products with low dielectric constants (from dielectric value 1.6) is possible.

Surge or bypass tubes must extend all the way down to the requested min. level, as measurement is only possible in the tube.

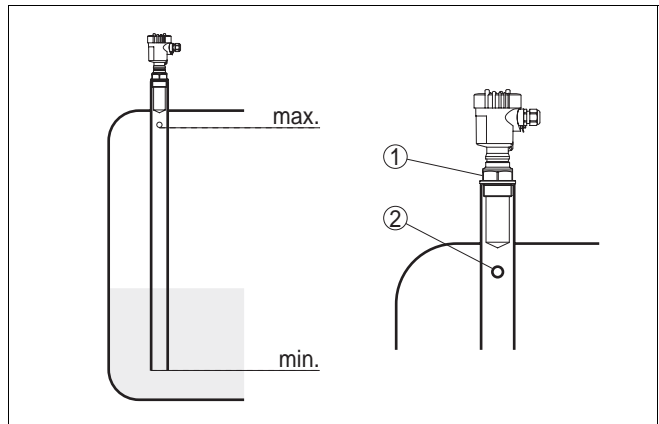

Fig. 12: Pipe antenna systems in a tank

- 1 Marking of the polarisation direction
- 2 Vent hole \varnothing max. 5 mm

The diameter of the sensor antenna should correspond to the inner diameter of the tube. With VEGAPULS 61 that is approx. 40 mm. The sensor can be used with tube diameters of 40 ... 80 mm.

Also take note of the necessary upper vent hole in the

surge pipe. It must be displaced by 90° to the polarisation marking on the sensor (see illustration: *Pipe antenna systems in a tank*).

As an alternative to the surge pipe in the vessel, a pipe system outside the vessel as bypass tube is also possible. Select the function "Bypass tube" during set-up.

Position the sensor in such a way that the polarisation marking on the process fitting is displaced by 90° to the holes or connection openings of the tube (see illustration: *VEGAPULS in a bypass tube*).

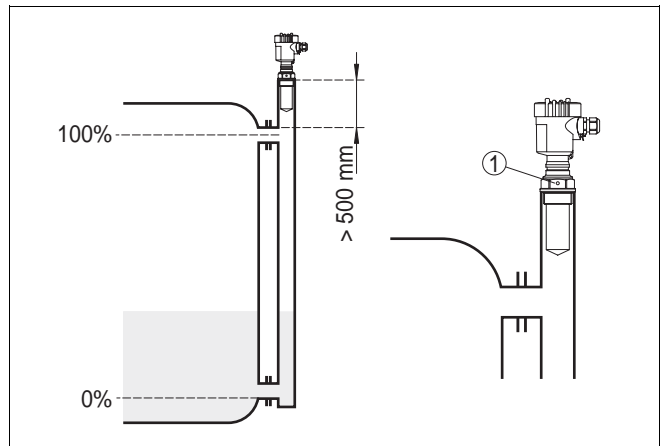

Fig. 13: VEGAPULS in a bypass tube

1 Marking of the polarisation direction

When mounting the sensor on a bypass tube, VEGAPULS 61 should be placed approx. 500 mm or more above the upper tube connection. If the inside of the tube is very rough, you should use an additional inserted tube (tube in tube) or a radar sensor with pipe antenna.

Adhesive products

Measurement in a standpipe is not recommended for very adhesive products.

Pressure

In case of gauge or low pressure in the vessel you should seal the process fitting on the thread. Check in advance if the seal material is resistant against the measured

product. The max. permissible pressure is stated in the Technical data in the Supplement or on the type label of the sensor.

5 Connecting to power supply

5.1 Preparing the connection

Note safety instructions

Always observe the following safety instructions:

- Connect only in the complete absence of line voltage
- If overvoltages are expected, overvoltage arresters should be installed.



Tip:

We recommend VEGA overvoltage arresters ÜS-F-LB-I and ÜSB 62-36G.X.

Take note of safety instructions for Ex applications



In hazardous areas you should take note of the appropriate regulations, conformity and type approval certificates of the sensors and power supply units.

Select voltage supply

Voltage supply and Stromausgang are carried on separate two-wire connection cables. The power supply range can differ depending on the instrument version. The exact range is stated in the Technical data in the Supplement.

With the standard version the current output can be operated ground-based, with the Exd version it must be operated floating.

This instrument is designed in protection class I. To maintain this protection class, it is absolutely necessary that the ground conductor is connected to the inner ground conductor terminal. Take note of the general installation regulations.

Connect VEGAPULS 61 generally to vessel ground (potential equalisation) or in case of plastic vessels to the next ground potential. A ground terminal is provided laterally on the instrument housing.

Select connection cable

An approved installation cable with PE conductor is necessary for power supply.

The 4 ... 20 mA current output is connected with standard two-wire cable. A cable outer diameter of 5 ... 9 mm ensures the seal effect of the cable entry. If electromagnetic interference is expected, we recommend the use of screened cable.

Screening and grounding

Connect the cable screen on both ends to ground potential. In the sensor, the screen must be connected directly to the inner ground terminal. The ground terminal outside on the housing must be connected to potential equalisation.

If potential equalisation currents are expected, the connection must be provided on the processing side via a ceramic capacitor (e.g. 1 nF, 1500 V). The low frequency potential equalisation currents are now avoided, the protective effect of the high frequency interference signals, however, remains.

Select connection cable for Ex applications



Take note of the corresponding installation regulations for Ex applications.

5.2 Connection procedure

Proceed as follows:

- 1 Unscrew the housing cover
- 2 Loosen compression nut of the cable entry
- 3 Remove approx. 10 cm of the cable mantle of the current output, strip approx. 1 cm insulation from the ends of the individual wires
- 4 Insert cable into the sensor through the cable entry
- 5 Lift the opening lever of the terminals with a screwdriver
- 6 Insert the wire ends into the open terminals according to the wiring plan
- 7 Press down the opening lever of the terminals, you will hear the terminal spring closing

- 8 Check the hold of the wires in the terminals by lightly pulling on them
 - 9 Connect screen to the inner ground terminal, connect the outer ground terminal to potential equalisation
 - 10 Tighten the compression nut of the cable entry, the seal ring must completely encircle the cable
 - 11 Connect the connection cable for power supply in the same way acc. to the wiring plan, in addition, connect ground conductor to the inner ground terminal
 - 12 Screw the housing cover back on
- The electrical connection is finished.



Fig. 14: Connection steps 5 and 6

5.3 Wiring plans, double chamber housing

Overview

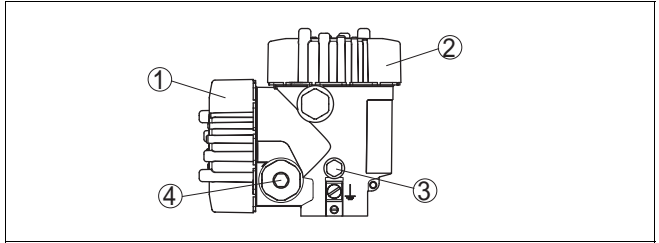

Fig. 15: Double chamber housing, non-Ex instrument or Exd instrument

- 1 Connection compartment
- 2 Electronics compartment
- 3 Breather element
- 4 Cable entry (pressure-tight with Exd)

Top view, electronics compartment (Exd and non-Ex)

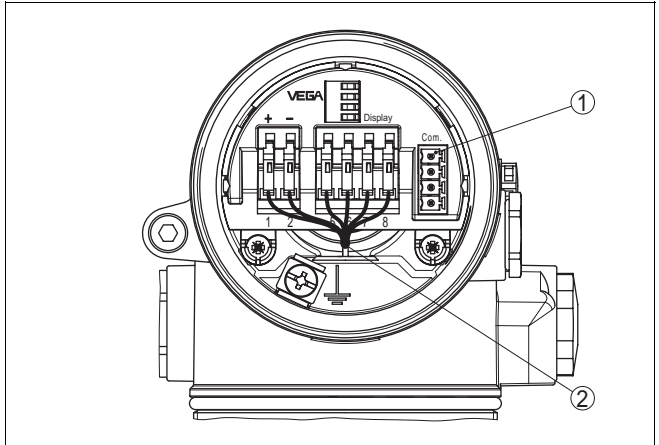

Fig. 16: Top view, electronics compartment, non-Ex instrument or Exd instrument

- 1 Plug connector for VEGACONNECT (I²C interface)
- 2 Internal connection cable to the connection compartment



Attention:

Never connect power supply in the electronics compartment, but only in the connection compartment.

Top view, connection compartment (Exd and non-Ex)

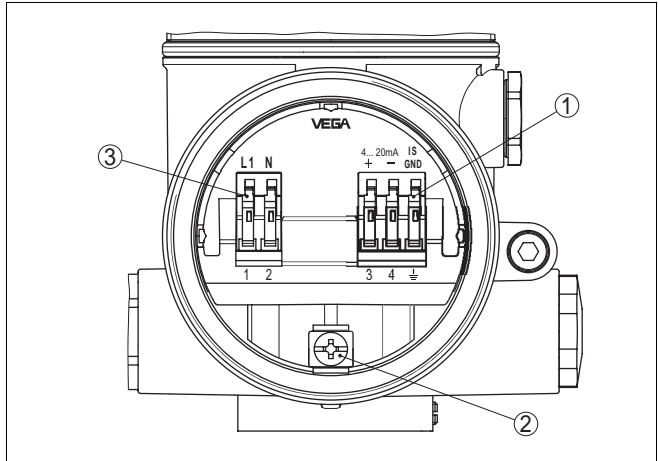

Fig. 17: Connection compartment, non-Ex instrument or Exd instrument

- 1 Spring-loaded terminals for 4 ... 20 mA output
- 2 Ground terminal for connection of the ground conductor and the cable screen
- 3 Spring-loaded terminals for power supply



Information:

Take note that the indicating and adjustment module PLICSCOM may be only used in the electronics compartment.

Wiring plan (Exd and non-Ex)

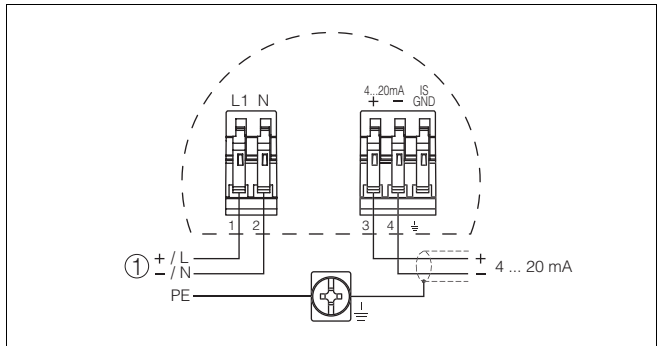

Fig. 18: Wiring plan, non-Ex instrument or Exd instrument

- 1 4 ... 20 mA connection/power supply

6 Set-up with the indicating and adjustment module PLICSCOM

6.1 Short description

Function/Configuration

The indicating and adjustment module PLICSCOM is used for measured value display, adjustment and diagnosis. It can be mounted in the following housing versions and instruments:

- all sensors of the plics® instrument family as well as in the single and double chamber housing (optionally in electronics or connection compartment)
- external indicating instrument VEGADIS 61

6.2 Installing the indicating and adjustment module PLICSCOM

Insert/remove PLICSCOM

PLICSCOM can be inserted or removed at any time. An interruption of the power supply is not necessary.

To install, proceed as follows:

- 1 Unscrew housing cover
- 2 Place PLICSCOM in the desired position on the electronics (you can choose any one of four different positions - each displaced by 90°)
- 3 Press PLICSCOM lightly onto the electronics and turn it to the right until it snaps in
- 4 Screw housing cover with inspection window tightly back on

Removal is carried out in reverse order.

PLICSCOM is powered by the sensor, an additional connection is not necessary.



Fig. 19: Installation of PLICSCOM



Note:

If you intend to retrofit VEGAPULS 61 with PLICSCOM for continuous measured value indication, an increased cover with inspection glass is needed.

6.3 Adjustment system

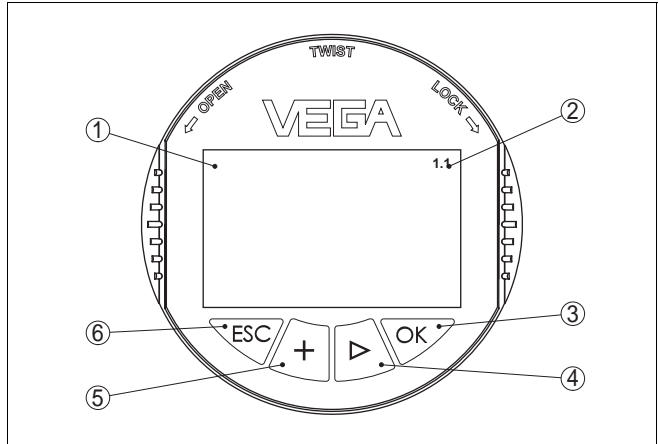

Fig. 20: Indicating and adjustment elements

1 **LC display for indication of:**

- measured value
- menu item
- parameter

2 **Indication of the menu item number**

3 **OK key:**

- move to the menu overview
- confirm selected menu
- edit parameter
- save value

4 **-> key to select:**

- menu change
- list entry
- editing position

5 **+ key:**

- modify value of a parameter

6 **ESC key:**

- interrupt input
- jump to the next higher menu

Adjustment system

The sensor is adjusted via the four keys of the indicating and adjustment module PLICSCOM. The LC display indicates the individual menu items. The functions are shown in the above illustration. Approx. 10 minutes after the last pressing of a key, an automatic reset to measured value display is triggered. Any values not confirmed with **OK** will not be saved.

6.4 Set-up procedure

Switching on phase

After VEGAPULS 61 is connected to power supply, the instrument carries out a self-test for approx. one minute. The following steps are carried out:

- internal check of the electronics
- indication of the instrument type, the firmware version as well as the sensor-TAG (sensor name)
- the output signal jumps briefly to the set fault current (HART sensor), i.e. the status byte changes to fault value (Profibus PA and FF sensors)

Then the actual measured value is displayed and the corresponding current (HART sensor) or digital output signal is transmitted over the cable (Profibus PA and FF sensors)¹⁾.

Parameter adjustment

Since VEGAPULS 61 is a distance measuring instrument, the distance from the sensor to the product surface is measured. In order to have the actual product level displayed, the height percentage must be set in relation to the measured distance. To make this adjustment, the full and empty distances in the vessel are entered. If these values are not known, it is possible to carry out the adjustment with distances of, e.g. 10 % and 90 %. Starting point for these distance values is always the seal surface of the thread or flange. The real level is then calculated on the basis of these settings. At the same time, the operating range of the sensor is reduced from the maximum range to the required range.

The actual product level does not play a role in this adjustment because the min./max. adjustment is always carried out without changing the product level. These settings can be carried out ahead of time without the instrument having to be installed.

¹⁾ The values correspond to the actual level as well as to the settings already carried out, e.g. default setting.

In order to ensure an optimum adjustment of the measurement, the individual submenu items in the main menu "Basic adjustment" should be selected one after the other and given the correct parameter values.



Note:

With HART Multidrop and Profibus PA the address should be set first. You will find a description in the operating instructions manual of PLICSCOM.

Start your parameter adjustment with the following menu items of the basic adjustment.

Carrying out min. adjustment

Proceed as follows:

- 1 Move from the measured value display to the main menu by pushing **[OK]**.

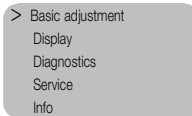

- 2 Select the menu item *Basic adjustment* with **[->]** and confirm with **[OK]**. Now the menu item "Min. adjustment" is displayed.

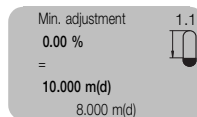

- 3 You prepare the percentage value for editing with **[OK]** and set the cursor to the requested position with **[->]**. Set the requested % value with **[+]** and save with **[OK]**. The cursor jumps now to the distance value.
- 4 Enter the distance value in m/ft corresponding to the percentage value for the empty vessel (e.g. distance from the sensor to the vessel bottom)
- 5 Save the settings with **[OK]** and move to max. adjustment with **[->]**.

Carrying out max. adjustment

Proceed as follows:

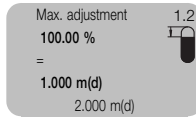

- 1 Prepare the percentage value for editing with **[OK]** and set the cursor to the requested position with **[->]**. Set the requested % value with **[+]** and save with **[OK]**. The cursor jumps now to the distance value.
- 2 Enter the distance value in m/ft corresponding to the percentage value for the full vessel. Remember that the max. level must be below the radar antenna.
- 3 Save the settings with **[OK]** and move to medium selection with **[->]**.

Medium selection

Each medium has different reflection characteristics. In liquids, agitated product surfaces and foam generation are additional interfering factors. In solids, interference is caused by dust generation, material cones and multiple echoes from the vessel wall. To adapt the sensor to the different measurement conditions, you first should select in this menu item *Liquid* or *Solid*.

Depending on the conductivity and the dielectric constant, liquids have different reflection characteristics. For this reason there are different options under the menu item "Liquid", such as *Solvents*, *Chemical mixtures* and *Water based*.

Under "Solids" you can select in addition *Powder/dust*, *Granular/pellets* or *Ballast/pebbles*.

Through this additional selection, the sensor is adapted perfectly to the product and its reliability, particularly when the product has poor reflective properties, is considerably increased.

Enter the requested parameters via the appropriate keys, save your settings and jump to the next menu item with the **[->]** key.

Vessel form

Apart from the medium, the vessel form can also impair the measurement. To adapt the sensor to these measurement conditions, this menu item offers additional options, different ones depending on whether Liquid or Solid was chosen. With *Liquid* these are *Storage tank*, *Stilling tube*, *Bypass tube*, *Stirrer vessel* or *Reaction vessel*, with *Solid* *Silo* or *Bunker*.

In standpipes or bypass tubes the radar pulses are transmitted by reflection inside the tube. This causes a shift of the running time dependent on the inner diameter. This influence is compensated by entering a value for the inner diameter.

Enter the requested parameters via the appropriate keys, save your settings and jump to the next menu item with the **[→]** key.

Damping

To suppress fluctuation in the measured value display, e.g. caused by agitated product surfaces, an integration time can be set. This time can be between 0 and 999 seconds. Please note that as a result, the reaction time of the entire measurement will be longer and the sensor will react to quick measured value fluctuations with a corresponding delay. In general, a period of a few seconds is sufficient to smooth the measured value display.

Enter the requested parameters via the appropriate keys, save your settings and jump to the next menu item with the **[→]** key.

Linearisation curve

A linearisation is necessary for all vessels in which the vessel volume does not increase linearly with the level - e.g. in a cylindrical or spherical tank - and the volume should be displayed or transferred. Corresponding linearisation curves are preprogrammed for these vessels. They represent the correlation between level percentage and vessel volume. By activating the suitable curve, the vessel volume percentage is displayed correctly. If the volume should not be displayed in percent, but e.g. in l or kg, a different display unit (scaled) can be set in the menu item "Display".

Enter the requested parameter via the appropriate keys, save your settings and jump to the next menu item with the **[->]** key.

Sensor-TAG

In this menu item you can enter an unambiguous designation for the sensor, e.g. the measurement loop name or the tank or product designation. In digital systems and in the documentation of larger plants, a unique designation should be entered for exact identification of individual measuring sites.

After this menu item the basic adjustment is finished and you can now return to the main menu with the **[ESC]** key.

False echo memory

High sockets or vessel installations such as e.g., struts or stirrers, as well as buildup or weld joints on the vessel wall can cause false echoes which can impair the measurement. A false echo storage detects and causes them to be disregarded in the level measurement. The false echo memory should be created when the vessel is empty, so that all potential interfering reflections can be detected.

Proceed as follows:

- 1 Move from the measured value display to the main menu by pushing **[OK]**.
- 2 Select the menu item *Service* with **[->]** and confirm with **[OK]**. Now the menu item "False echo memory" is displayed.
- 3 Confirm *False echo memory - change* with **[OK]** and select in the lower menu *Create new*. The actual distance from the sensor to the product surface is entered here. All false echoes in this range are detected by the sensor and saved after being confirmed with **[OK]**.



Note:

Check the distance to the product surface, because the actual level will be saved as a false echo in case of a wrong (too large) setting. If this happens, the level can no longer be detected in this range.

Additional adjustment options

Additional adjustment and diagnosis options such as e.g. scaling, simulation or echo curve presentation are shown in the following menu schematic. You can find a detailed description of these menu items in the operating instructions manual of the indicating and adjustment module PLICSCOM.

6.5 Menu schematic

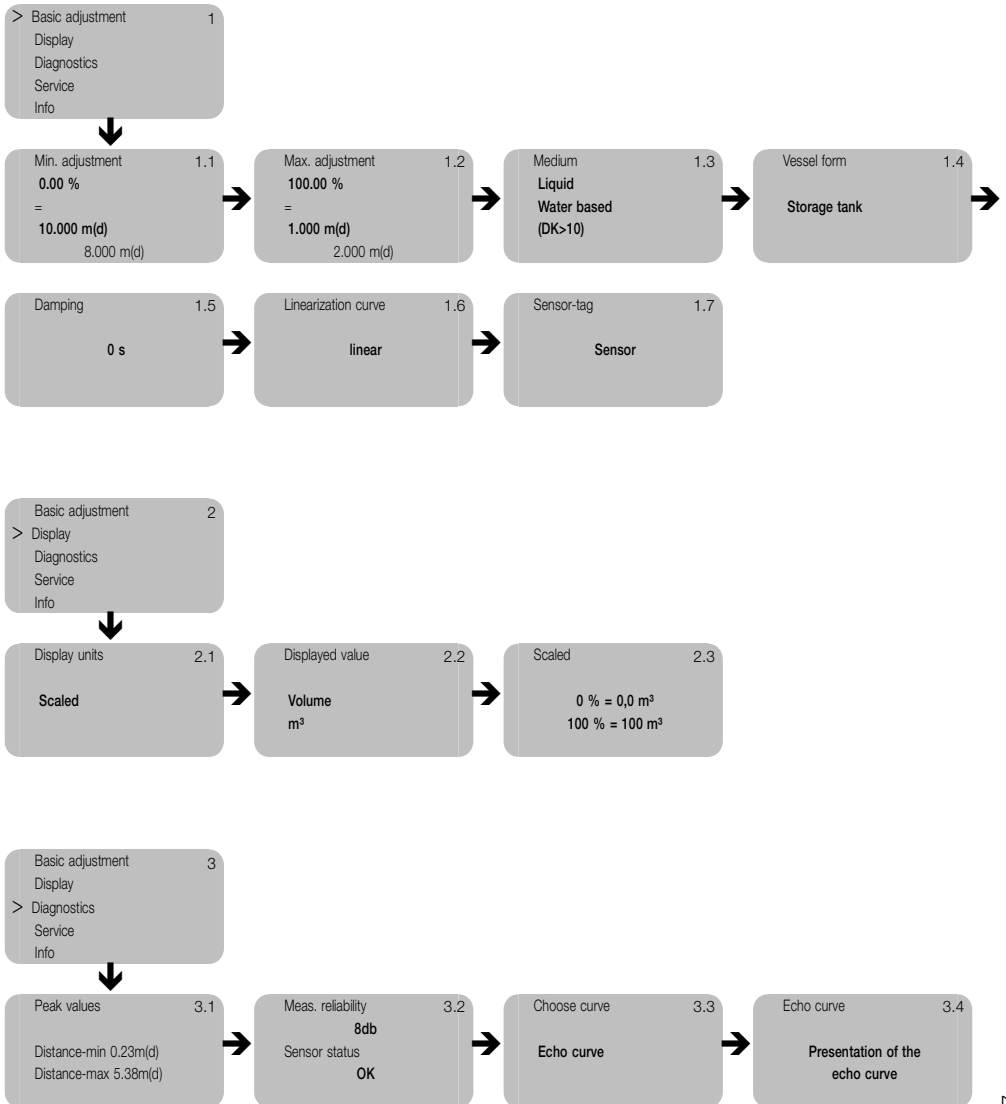

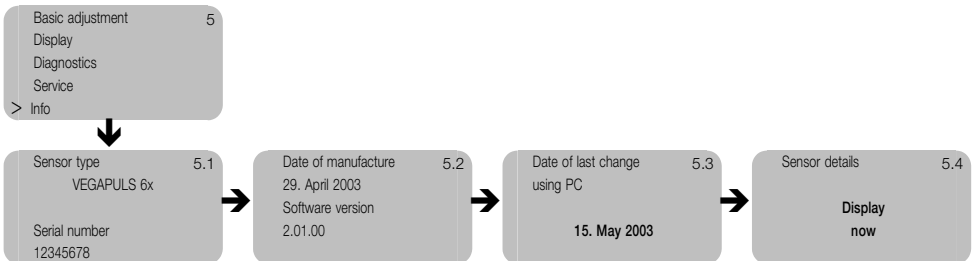
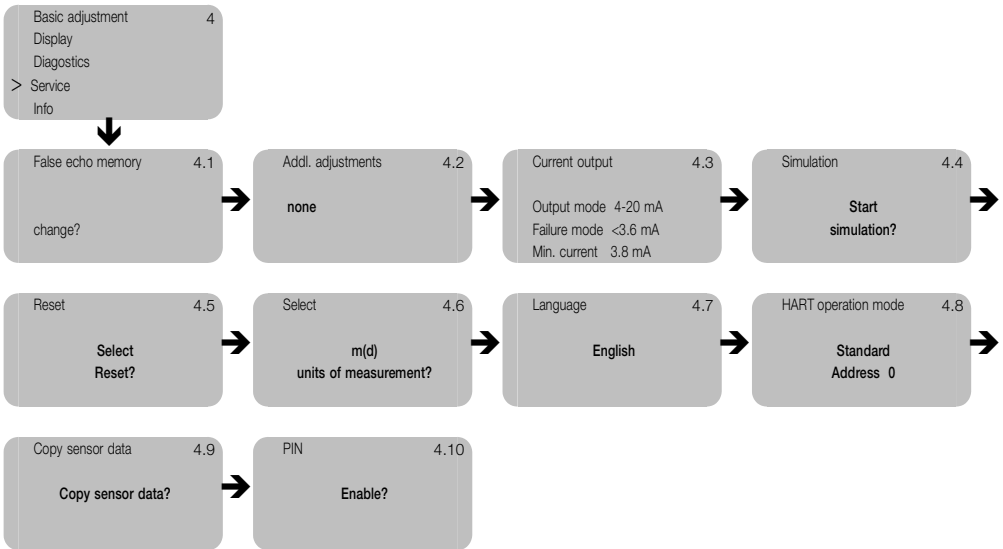

7 Set-up with PACTware™

7.1 Connecting the PC

Connecting the PC directly to the sensor

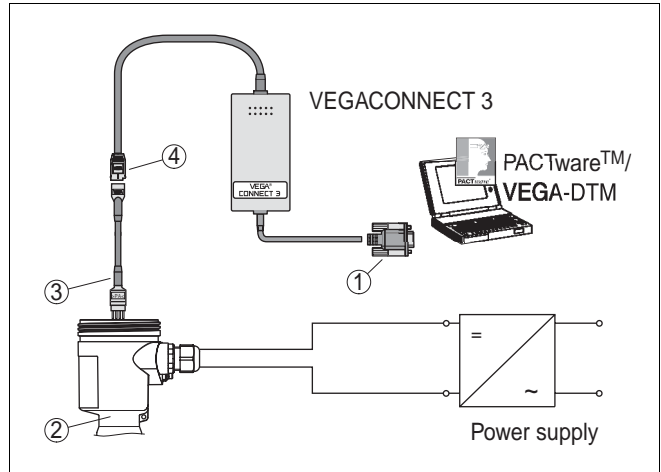

Fig. 21: PC connected directly to the sensor

- 1 RS232 connection
- 2 VEGAPULS 61
- 3 I²C adapter cable for VEGACONNECT 3
- 4 I²C bus plug

Necessary components:

- VEGAPULS 61
- PC with PACTware™ and suitable VEGA-DTM
- VEGACONNECT 3 with I²C adapter cable (article no. 2.27323)
- power supply unit



Tip:

Further set-up steps are described in the operating instructions manual *DTM Collection/PACTware* attached to each CD and which can be downloaded from our homepage. A detailed description is available in the online help of PACTware™ and the VEGA-DTMs.

Connecting the PC to the signal cable

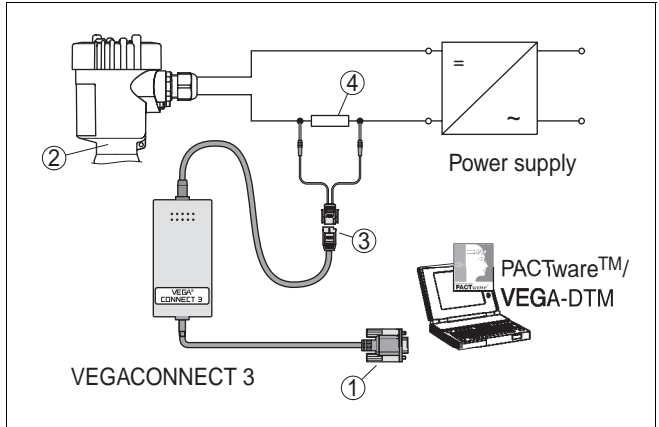

Fig. 22: PC connected to the signal cable

- 1 RS232 connection
- 2 VEGAPULS 61
- 3 VEGACONNECT 3 adapter cable for HART
- 4 HART resistance 250 Ohm

Necessary components:

- VEGAPULS 61
- PC with PACTware™ and suitable VEGA-DTM
- VEGACONNECT 3 with adapter cable for HART
- HART resistance 250 Ohm
- power supply unit



Note:

With power supply units with integrated HART resistance, an additional external resistance is no longer necessary. In such cases, VEGACONNECT 3 can be connected in parallel to the power supply.

8 Maintenance and fault rectification

8.1 Maintenance

In normal operation, VEGAPULS 61 is completely maintenance-free.

8.2 Fault rectification

Checking the 4 ... 20 mA signal

Connect a hand-multimeter with the suitable measuring range acc. to the wiring plan.

? 4 ... 20 mA signal not stable

- level fluctuations
- set integration time via PLICSCOM or PACTware™

? 4 ... 20 mA signal missing

- incorrect connection to power supply
- check connection acc. to chapter "Connection procedure" and correct if necessary acc. to chapter "Wiring plans"
- no power supply
- check cables for line break, repair if necessary
- power supply too low or load resistance too high
- check and adapt if necessary

? Current signal more than 22 mA or 0 mA

- electronics module defective
- exchange instrument or return for repair



In Ex applications, the regulations for the wiring of intrinsically safe circuits must be observed.

**Fault messages via
PLICSCOM****? E013**

- no measured value available
- sensor in boot phase
- sensor does not find an echo, e.g. due to wrong installation or parameter adjustment

? E017

- adjustment span too small
- carry out a new adjustment, increase distance between min. and max. adjustment

? E036

- no operable sensor software
- carry out software update or return instrument for repair

? E042/E043

- hardware error, electronics defective
- exchange instrument or return for repair

8.3 Repairing the instrument

If it is necessary to repair VEGAPULS 61 , please send the instrument to the following address:

VEGA Grieshaber KG; Repair department; Am Hohenstein 113; 77761 Schiltach/Germany

9 Dismounting

9.1 Dismounting procedure

Take note of chapters "Mounting" and "Connecting to power supply" and carry out the listed steps in reverse order.

9.2 Disposal

VEGAPULS 61 consists of materials which can be recycled by specialised recycling companies. We have purposely designed the electronic modules to be easily separable. Mark the instrument as scrap and dispose of it according to government regulations (electronic scrap ordinance, etc.).

Materials: see Technical data

If you cannot dispose of the instrument properly, please contact us about disposal methods or return.

10 Supplement

10.1 Technical Data

General data

Materials, wetted parts

- | | |
|--|---|
| <ul style="list-style-type: none"> – process fitting | thread G 1½ A and 1½ NPT: PVDF, Tri-Clamp 2" and 3", bolting DN 50 and DN 80: adapter of stainless steel 1.4435 |
| <ul style="list-style-type: none"> – antenna | PVDF |
| <ul style="list-style-type: none"> – seal thread | FPM |
| <ul style="list-style-type: none"> – seal Tri-Clamp and bolting | Viton |

Materials, non-wetted parts

- | | |
|---|--|
| <ul style="list-style-type: none"> – housing | plastic PBT (Polyester), Alu-die casting powder-coated, stainless steel 1.4435 |
| <ul style="list-style-type: none"> – seal ring between housing and housing cover | NBR (stainless steel housing), silicone (alu/plastic housing) |
| <ul style="list-style-type: none"> – inspection window in housing cover for PLICSCOM | Polycarbonate |
| <ul style="list-style-type: none"> – ground terminal | stainless steel 1.4571/1.4435 |

Weight

0.7 ... 3.4 kg (depending on process fitting and housing)

Output variable

Output signal	4 ... 20 mA/HART
Resolution	1.6 μ A
Fault signal	current output unchanged, 20.5 mA, 22 mA, < 3.6 mA (adjustable)
Current limitation	22 mA
Load	
– 4-wire sensor	max. 500 Ohm ²⁾
– 2-wire sensor	see load diagram in Power supply
Integration time (63 % of the actual height)	0 ... 999 s, adjustable
Rise time	150 ms (ti : 0 s, 0 ... 100 %)
Fulfilled Namur recommendation	NE 43

Input variable

Parameter	distance between process fitting and product surface
Min. distance from the antenna end	50 mm
Measuring range	up to 10 m

Accuracy (similar to DINV 19259-1 and IEC 60770-1)

Reference conditions acc. to IEC 60770-1	
– temperature	18 ... 30°C
– relative humidity	45 ... 75 %
– pressure	860 ... 1060 mbar (86 ... 106 kPa)
Determination of characteristics	limit point adjustment acc. to DIN 16086
Characteristics	linear

²⁾ with inductive load, ohmic share at least 25 Ohm/mH

Deviation from characteristic curve and measurement characteristics ³⁾

Average temperature coefficient of the zero signal (temperature error)	0.06 %/10 K
Resolution, general	max. 1 mm
Frequency	K-band (26 GHz technology)
Interval	approx. 1 s
Beam angle at -3 dB	22°
Adjustment time ⁴⁾	> 1 s (depending on the parameter adjustment)
max. emitted power	<25 mW EIRP ⁵⁾
Average power	
Received average emitted power reaching an object directly in front of the antenna	
– distance 1 m	0.4 ... 3.2 nW per cm ² (0.4 ... 3.2 x 10 ⁻⁹ W/cm ²)
– distance 5 m	0.02 ... 0.13 nW per cm ² (0.02 ... 0,13 x 10 ⁻⁹ W/cm ²)
Accuracy	see diagram

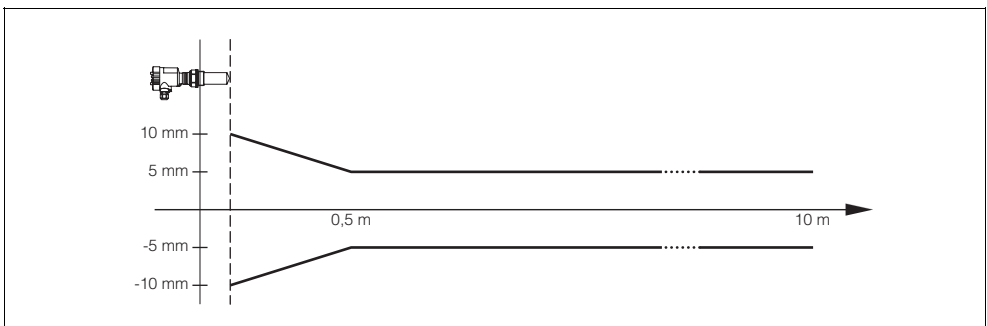

Fig. 23: Accuracy VEGAPULS 61

³⁾ In relation to the nominal range, incl. hysteresis and repeatability, determined and acc. to the limit point method.
⁴⁾ Time required to output the correct level (with max. 10 % deviation) after a sudden level change.
⁵⁾ EIRP: emitted power relating to an isotropic radiator.

Ambient conditions

Ambient, storage and transport temperature

- | | |
|--------------------|---------------|
| – without PLICSCOM | -40 ... +80°C |
| – with PLICSCOM | -40 ... +70°C |
-

Process conditions

- | | |
|--|---|
| Vessel pressure | -100 ... 300 kPa (-1 ... 3 bar) |
| Process temperature (flange temperature) | -40 ... +130°C |
| Vibration resistance | mechanical vibrations with 4 g and 5 ... 100 Hz ⁶⁾ |
-

Electromechanical data

Cable entry/plug (depending on the version)

- | | |
|--------------------------|--|
| – single chamber housing | <ul style="list-style-type: none"> ● 1 x cable entry M20x1.5 (cable-ø 5 ... 9 mm), 1 x blind stopper M20x1.5 <p>or:</p> <ul style="list-style-type: none"> ● 1 x closing cap ½ NPT, 1 x blind stopper ½ NPT <p>or:</p> <ul style="list-style-type: none"> ● 1 x plug M12x1, 1 x blind stopper M20x1.5 |
| – double chamber housing | <ul style="list-style-type: none"> ● 1 x cable entry M20x1.5 (cable-ø 5 ... 9 mm), 1 x blind stopper M20x1.5 <p>or:</p> <ul style="list-style-type: none"> ● 1 x closing cap ½ NPT, 1 x blind stopper ½ NPT <p>or:</p> <ul style="list-style-type: none"> ● 1 x plug M12x1, 1 x blind stopper M20x1.5 |
| Spring-loaded terminals | for wire-cross sections up to 2.5 mm ² |
-

⁶⁾ Tested acc. to the reg. of German Lloyd, GL-directive 2

Indicating and adjustment module PLICSCOM

Power supply and data transmission	through sensor via gold-plated sliding contacts (I ² C bus)
Display	LC display in full dot matrix
Adjustment elements	4 keys
Protection	IP 20 (mounted into sensor without housing cover; IP 40)
Materials	
– housing	ABS
– inspection window	Polyester foil

Power supply

Power supply

– Non-Ex and Ex d instrument

20 ... 72 V DC, 20 ... 253 V AC, 50/60 Hz

Power consumption

max. 4 VA, 2.1 W

Electrical protective measures

Protection

IP 66/IP 67

Overvoltage category

III

Protection class

I

Approvals ⁷⁾

ATEX II 1G, 1/2G, 2G EEx ia IIC T6,

ATEX II 1/2G, 2G EEx d ia IIC T6, WHG,

ship approvals

⁷⁾ Deviating data with Ex applications: see separate safety instructions

10.2 Dimensions

VEGAPULS 61

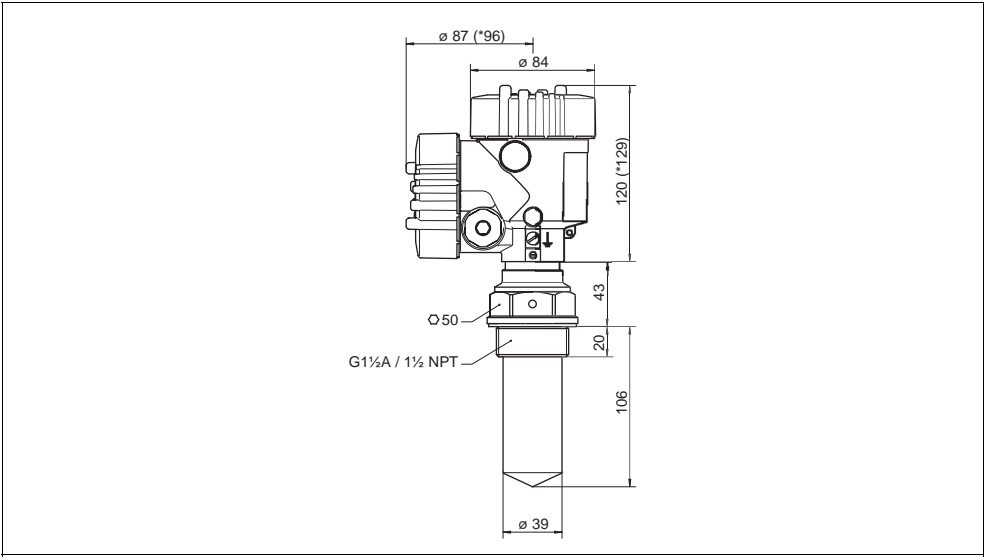

Fig. 24: VEGAPULS 61

* dimension with integrated PLICSCOM