

Operating Instruction

VEGADIS 371 Ex

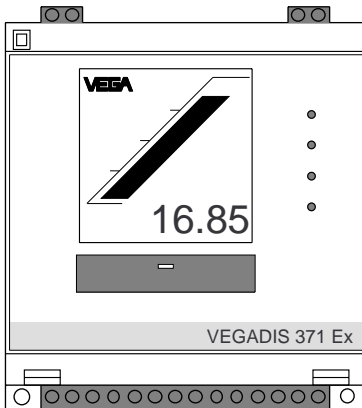

Contents

Safety information	2
1 Product description	
1.1 Function and configuration	3
1.2 Types and versions	3
1.4 Dimensions	3
1.3 Approvals	3
1.5 Technical data	4
2 Mounting	
2.1 Mounting instructions	5
3 Electrical connection	
3.1 Sensor connection	6
3.2 Sensor connection Ex-area	7
3.3 Terminal coordination	8
3.4 Ex-separating chamber	8
4 Set-up	
4.1 Indicating and adjustment elements	9
4.2 Adjustment	11
4.3 Mounting of the relay modules	14
4.4 Reset	15
5 Diagnosis	
5.1 Simulation	16
5.2 Fault signals	16

Safety information

The described module must only be installed and operated as described in this operating instruction. Please note that other action can cause damage for which VEGA does not take responsibility.

1 Product description

1.1 Function and configuration

VEGADIS 371 Ex is a digital indicating instrument with integral level switches and current output for panel, surface or rail mounting with LC-display for digital and quasianalogue demonstration.

Max. 4 relays in pairs can be used as relay modules. The modules can be retrofitted. VEGADIS 371 Ex is an indicating instrument and can hence not be adjusted.

The indication is individually scalable between -9999 and 9999. The decimal point can be shifted. The indicated unit can be chosen individually. You can add a label with the units to the cover.

Configuration

Any sensor can be connected to the meas. circuit of VEGADIS 371 Ex delivering a standardized 4 ... 20 mA-signal or a 0 ... 10 V-signal.

1.2 Types and versions

VEGADIS 371

Digital indicating instrument with integral level switches for front panel mounting or surface mounting.

VEGADIS 371 Ex

Digital indicating instrument with integral level switches for front panel mounting or surface mounting with Ex-approval.

1.3 Approvals



VEGADIS 371 Ex (appropriate apparatus) is available with the following approval:

Explosion protection

- Classification

II 1G [EEx ia] IIC EC-type approval
TÜV 97 ATEX 1174,

- Conformity certificate

PTB no. Ex-97.D.2073 X.

For these applications note the appropriate legal documents (EC-type approval and conformity certificate). These are supplied with the instrument.

VEGADIS 371 EX



Ex-relevant technical data are stated in the following attached documents:

EC-type approval TÜV 97 ATEX 1174

Conformity certificate PTB no. Ex-97.D.2073 X

CE-conformity



VEGADIS 371 Ex meets the protective regulations of EMVG (89/336/EWG) and NSR (72/23/EWG). The conformity has been judged acc. to the following standards:

EMVG	Emission	EN 50 081 - 1: 1992
	Susceptibility	EN 50 082 - 2: 1995
NSR		EN 60 010 - 1: 1993

1.4 Dimensions

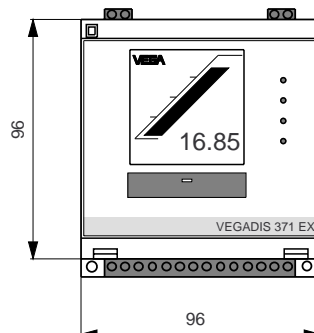
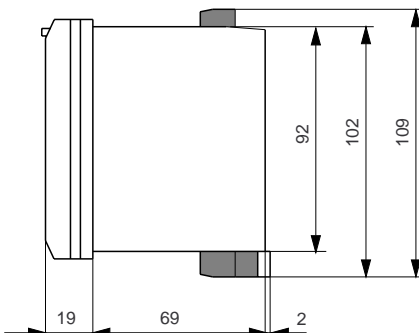

1.5 Technical data

General

Series	instrument for front panel or wall mounting or mounting on rail 35 x 7,5
Dimensions	W = 96 mm, H = 104 mm, D = 90 mm
Weight	approx. 400 g
Housing material	plastic ABS/POM
Cross section area of conductor	max. 2,5 mm ²

Ambient conditions

Permissible ambient temperature	-20°C ... +60°C
Storage and transport temperature	-40°C ... +85°C
Temperature error	0,01 %/K

Electrical protective measures

Protection class	II
Overvoltage category	II
Protection	
- wall or carrier rail mounting	IP 20
- front panel mounting	IP 40

Voltage supply

Supply voltage	20 ... 250 V AC/DC
Power consumption	4 W, 12,5 VA

Sensor input (floating)

Transmission	analogue
Connection line to the sensor	2-wire
I_{active}	
- sensor supply	25 ... 15 V (range 4 ... 20 mA)
- shortcircuit limitation	approx. 30 mA
I_{passive}	
- inner resistance	< 250 Ω (range 4 ... 20 mA)
U	
- inner resistance	> 100 Ω (range 0 ... 10 V)

Current output 0/4 ... 20 mA (signal circuit, floating)

Resolution	0,1 % (range 0/4 ... 20 mA)
max. load	500 Ω
Fault signal	approx. 22 mA
Linearity error	0,1 %

Relay output

Number of relays	4 (2 modules with 2 relays each)
Turn-on voltage	min. 10 mV max. 250 V AC, 250 V DC
Switching current	min. 10 μA max. 3 A AC, 1 A DC
Breaking capacity	max. 54 W DC, 500 VA AC
Indication of switching condition	LED lights - relay energized LED off - relay deenergized

Digital indication

Zero point (4 mA or 0 V)	-9999 ... 9999
Final point (20 mA or 10 V)	-9999 ... 9999
Decimal point	individually selectable

2 Mounting

2.1 Mounting instructions

VEGADIS 371Ex indicating instrument can be either mounted directly to the wall with three screws, plugged on carrier rail 35 x 7,5 acc. to DIN EN 50 022 or lowered into a front panel. VEGADIS 371Ex must be generally mounted outside hazardous areas.

Before mounting VEGADIS 371 you should adjust the requested sensor signal (I_a , I_p , U). The slide switch on the rear of VEGADIS 371 under the cover is no more accessible after mounting the instrument. Dependent on the application and the sensor you can choose between active current measurement (I_a), passive current measurement (I_p) or voltage measurement (U). Factory setting " I_a " see also "4.2 Adjustment". The position of the switch also modifies the application conditions for Ex-instruments (VEGADIS 371Ex). Note the type approval or the conformity certificate of VEGADIS 371Ex.

Carrier rail mounting

- Place the adapter plate (A) to the rear of VEGADIS 371 (spring of the adapter plate to the bottom) and tighten the plate with screw B (M4 x 6).
- Place VEGADIS 371 from the bottom to the carrier rail (C) and push the instrument to the top until snap-in.

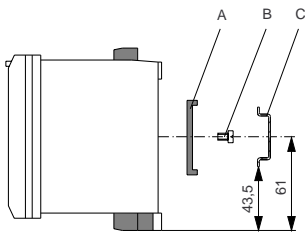

Wall mounting

- Insert the metal sleeve (D) from top into the housing cut-out.
- Fasten the instrument with three screws (\varnothing max. 4 mm) directly to the wall.

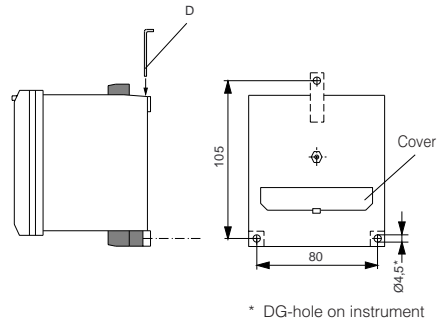

Front panel mounting

- Remove the two pluggable terminal boards (F) and the terminal board (K) to the top.
- Screw the pin (H) to the rear of VEGADIS 371 and tighten with a screwdriver.
- Insert VEGADIS 371 from the front into the front panel (E).
- Push the terminal strap (G) from the back to the pin (H) and pull with the knurled nut (I) against the front panel (E).

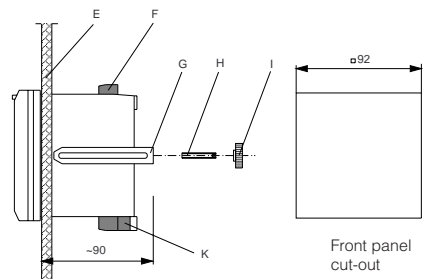

3 Electrical connection

3.1 Sensor connection

Note

Switch off the voltage supply before starting connection work.

Active operation (I_a)¹⁾

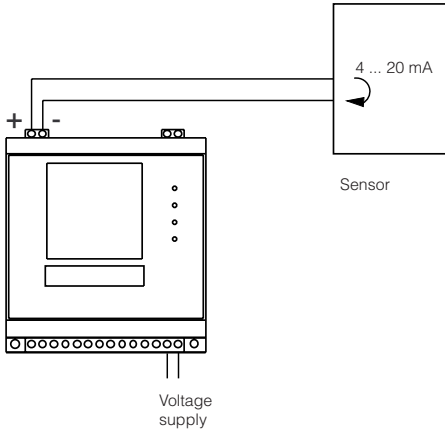

Passive operation (I_p)¹⁾

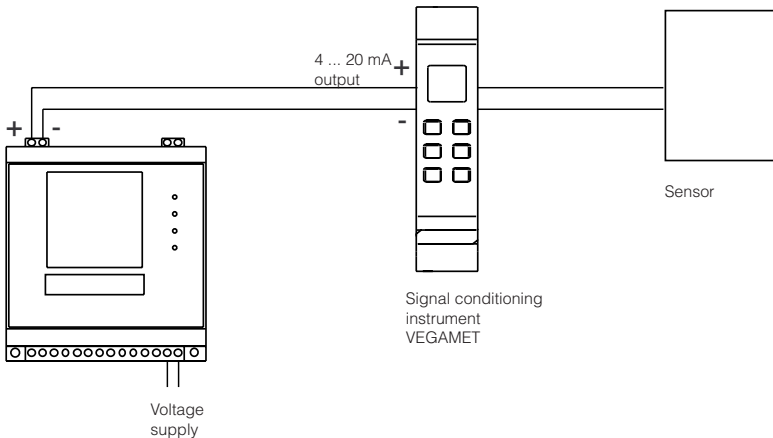

1) Active or passive operation selectable with slide switch.
See "4.1 Indicating and adjustment elements"

3.2 Sensor connection Ex-area

Note:

When using VEGADIS 371 the connection of an ia-safety barrier type 145 is not possible. For the use on sensors in hazardous areas, use VEGADIS 371 Ex.

VEGADIS 371 Ex must be generally mounted outside hazardous areas.

Active operation (I_a)¹⁾

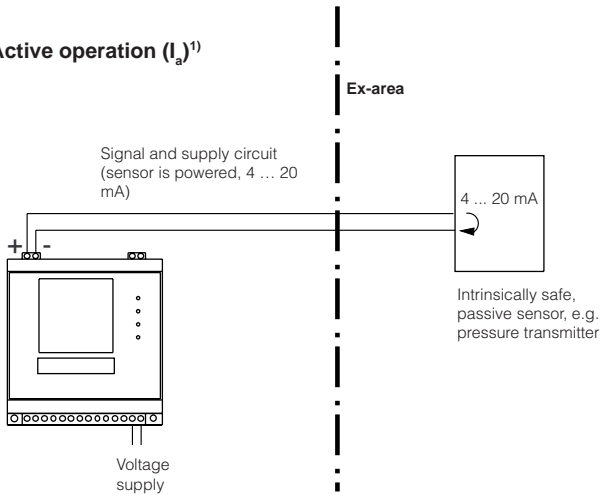

Passive operation (I_p)¹⁾

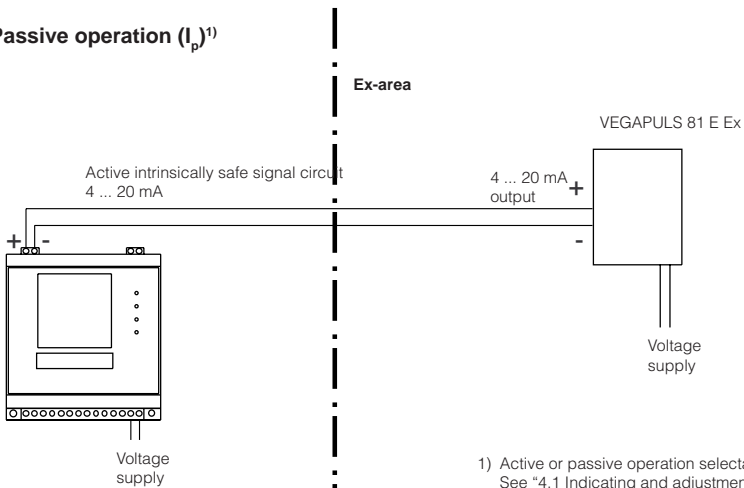

1) Active or passive operation selectable with slide switch. See "4.1 Indicating and adjustment elements"

3.3 Terminal coordination

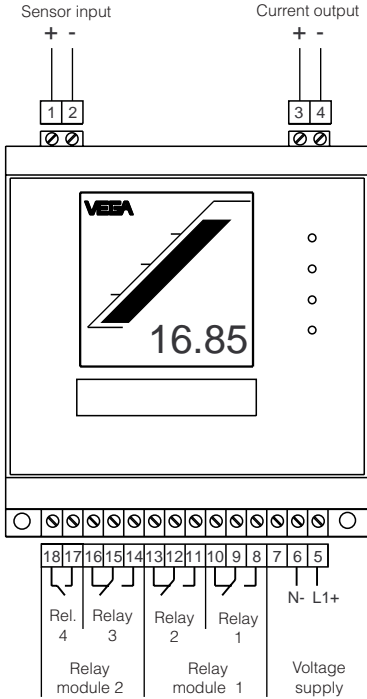

When switching on voltage supply, the software version of VEGADIS 371 is displayed for approx. 4 seconds.

3.4 Ex-separating chamber

When several instruments are mounted in a row, the blue Ex-separating chamber must be plugged to the terminals of the sensor input (terminals 1 and 2) on VEGADIS 371 Ex, to ensure the required distance (50 mm).

- Place the Ex-separating chamber acc. to the figure to the terminals of the sensor input (terminals 1 and 2) and loop the sensor line to the front out of the Ex-separating chamber.
- Push the Ex-separating chamber to the front until snap-in.

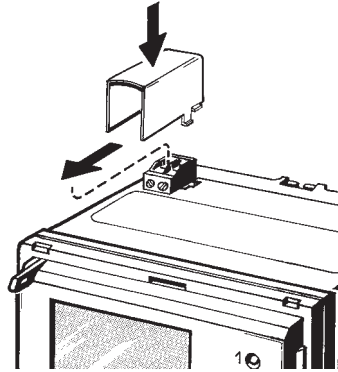

4 Set-up

4.1 Indicating and adjustment elements

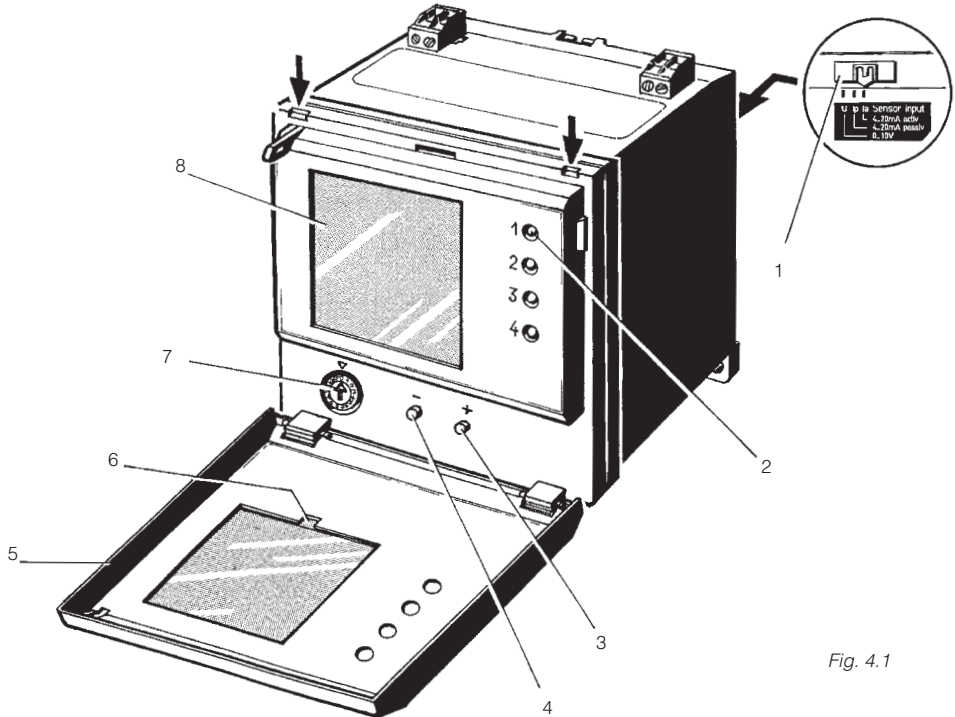

Fig. 4.1

- 1 Slide switch
- 2 Relay control lamps (1 ... 4)
- 3 Plus key
- 4 Minus key
- 5 Cover
- 6 Shackle
- 7 Rotating switch
- 8 Digital indication

The figures in brackets relate to the information in figure 4.1.

To open the cover (5), insert a screwdriver into the two slots marked with arrows.

Turn the screwdriver by a quarter turn and the cover (5) opens.

To protect the instrument against unauthorized adjustment, the cover (5) of VEGADIS 371 can be sealed. Insert the seal wire with closed cover in the top left corner through the hole of the lug.

Designation:

In practise it has proven to mark VEGADIS. Information on the appropriate measurement loop and the unit of the indicated value help to avoid failures and misunderstandings. On the housing a shackle (6) is provided for designation. Here you can insert one of the supplied labels.

Rotating switch (7)

Stage 1

In menu stage 1 you find all necessary functions which are necessary for adjustment of the indicating instrument. When you are in menu stage 1, the "VEGA"-logo is shown **non-flashing**.

Note

When you want to activate the pump changeover function, all relay outputs you want to coordinate to the pump changeover function must have the same function. When relay 1 e.g. switches on when the adjusted max. value is reached, all following relays must have the same adjustment.

0 - OPERATE	= Indication measured value
1 - Relay 1 on	= Relay 1 on
2 - Relay 1 off	= Relay 1 off
3 - Relay 2 on	= Relay 2 on
4 - Relay 2 off	= Relay 2 off
5 - Relay 3 on	= Relay 3 on
6 - Relay 3 off	= Relay 3 off
7 - Relay 4 on	= Relay 4 on
8 - Relay 4 off	= Relay 4 off
9 - t_i	= Integration time
A - Out 0 ... 20 mA, Out 4 ... 20 mA	= Current output
B - Display min	= Scaled indication at 0 %
C - Display max	= Scaled indication at 100 %
D - Decimal point	= Decimal point
E - Offset correction	= Offset correction
F - Simulation	= Simulation

Stage 2

In menu stage 2 you find the functions which are necessary for adjustment of the pump changeover function.

In rotating switch position 0 (Operate) you have to push the plus and minus key together for approx. 3 seconds to change to menu stage 2 (pump changeover function). When you are in menu stage 2, the "VEGA"-logo **flashes** on the display. Push again both keys to return to menu stage 1. After approx. 10 minutes the indication changes automatically to menu stage 1.

With the rotating switch (16 steps) you choose the appropriate function.

0	- OPERATE	= Indication of meas. value
1	= Pump changeover function Relay 1 on/off	
2	= Operating time indication Rel 1	
3	= Pump changeover function Relay 2 on/off	
4	= Operating time indication Rel 2	
5	= Pump changeover function Relay 3 on/off	
6	= Operating time indication Rel 3	
7	= Pump changeover function Relay 4 on/off	
8	= Operating time indication Rel 4	
9	= ---- (not coordinated)	
A	= ---- (not coordinated)	
B	= ---- (not coordinated)	
C	= ---- (not coordinated)	
D	= ---- (not coordinated)	
E	= ---- (not coordinated)	
F	= ---- (not coordinated)	

Plus/Minus keys (3 and 4)

With these keys you modify the value of the digital indication. When you keep the key pushed, the digital indication changes its value with raising speed.

Slide switch (1)

With the slide switch on the rear of the instrument you can changeover between voltage measurement, active sensor input and passive sensor input.

I_a - Active operation: The sensor is powered by VEGADIS 371. Sensors connected in this configuration are called passive sensors. VEGADIS 371 reacts like a current source.

I_p - Passive operation: VEGADIS 371 is connected to the sensor line (current input 4 ... 20 mA). Sensors connected in this configuration are called active sensors. VEGADIS 371 reacts like a current sink.

U - VEGADIS measures the voltage 0 ... 10 V

Note

The position of the switch changes also the application conditions for Ex-instruments (VEGADIS 371 Ex).

Also note the type approval or the conformity certificate of VEGADIS 371 Ex.

4.2 Adjustment

Stage 1

When switching on the voltage supply, the LED of the relays shortterm light and the display indicates for approx. 4 seconds the software version of VEGADIS 371.

The figures in brackets relate to the figure under 4.1 Indicating and adjustment elements.

Course

- Choose the requested mode with the rotating switch (7).
- Push one of the two keys (3 or 4). The digital indication (8) begins to flash.
- Push one of the two keys to change the value of the digital indication appropriately. When the rotating switch (7) is set to "OPERATE", the keys (3 and 4) are without function.
- You can save the adjusted value by changing the position of the rotating switch (7).

Example

- an upright cylindrical (linear) tank with a content of 2700 l.
- the max. volume is 2650 l, the min. volume 50 l.
- the level sensor in the vessel is a pressure transmitter (passive), providing a standardized 4 ... 20 mA-signal.
- for further processing you need an additional 4 ... 20 mA-output signal.
- the full and empty adjustment had been carried out correctly. The sensor delivers the following values:
Max. volume (display max.)
20 mA = 2650 l
Min. volume (display min.)
4 mA = 50 l
- relay 1 should switch on an emptying pump at a volume of 90 % and switch off the pump at a volume of 10 %.

First choose the parameters of your application:

Slide switch

- loosen the cover on the rear of VEGADIS 371 with a screwdriver. Under this cover there is a slide switch (1) by which you can adjust the kind of input:

I_{active} = active current input (I_a)
 I_{passive} = passive current input (I_p)
 U = voltage measurement (U)

For the given example choose I_a (active current input).

Current output

- Set the rotating switch (7) to position A. With the keys (3 and 4) you can choose between measured value output 4 ... 20 mA or 0 ... 20 mA.
For the given example choose 4 - 20.

The display indications have the following meaning:
0 - 20 = 0 ... 20 mA; 4 - 20 = 4 ... 20 mA

VEGADIS 371 requires for the scaling of the indication the adjustment of the volumes for 4 mA and 20 mA. The vessel must not be filled or emptied. Proceed as follows to adjust the two values:

Decimal point

VEGADIS 371 requires for this example the adjustment of the values for 4 mA and 20 mA (0 % and 100 %). As the range of the example tank is from 50 l to 2650 l, you require all four positions of the digital indication.

- Set the rotating switch (7) to position D (Decimal Point).
- By pushing the keys (3 and 4) you move the decimal point.

Scaled indication at 0 %

- Set the rotating switch (7) to position B (Display min.).
- Push the plus key (3) to increase the indicating value or the min. key (4) to reduce the indicating value (0,1 %-steps).
- When you keep the key pushed, the digital indication (8) changes the indicating value quicker.
For the given example adjust the digital indication (8) to the value 50.

Scaled indication at 100 %

- Set the rotating switch (7) to position C (Display max.).
- Push the plus key (3) to increase the indicating value or the minus key (4) to reduce the indicating value (0,1 %-steps).
- For the given example set the digital indication (8) to the value 2650.

Relay

- Set the rotating switch (7) to position 1 (relay 1 on). When the selected relay is not mounted, four dashes appear on the digital indication. With the keys (3 and 4) you can modify the value of the indication. For the given example set the digital indication (8) to the value 90,0 (90,0 %). Hence the internal relay 1 switches on when this value is reached.

- Set the rotating switch (7) to position 2 (relay 1 off). With the keys (3 and 4) you can change the value of the indication. For the given example you set the digital indication (8) to the value 10,0 (10,0 %). Hence the internal relay 1 switches off when this value is decreased. The appropriate relay control lamp (2) lights when the relay is energized. When the switch points are too close together (< 0,1 %), the appropriate LED flashes. The relay takes the safe condition. In mode "Operate" a fault signal is displayed.
- When you want to control further relays, proceed in the same way than for relay 1. The positions for adjustment of the appropriate relays are stated in the list of the rotating switch (7) under 4.1 Indicating and adjustment elements.

Note

When you want to change the mode (i.e. the switching function of the relays) you have to exchange the on and off-values (see fig. 4.2)

- Mode A (overflow protection)
switch on point < switch off point
To adjust e.g. for relay 1 mode A (overflow protection) you have to enter with position 1 (relay 1 on) of the rotating switch (7) the lower value and with position 2 (relay 1 off) the higher value. Hence relay 1 is switched off when the max. level is reached (deenergized condition) and switched on when min. level is reached.
- Mode B (dry run protection)
switch on point > switch off point
When you want to adjust mode B (dry run protection) for relay 1, you have to enter with position 1 (relay 1 on) of the rotating switch (7) the higher value and with position 2 (relay 1 off) the lower value. Hence relay 1 is switched on when

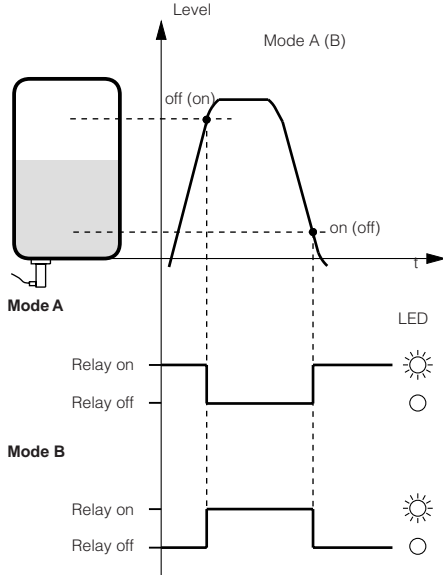

Fig. 4.2

max. level is reached and switch off (deenergized condition) when min. level is reached.

Integration time

- When you want to adjust an integration time (reaction delay), set the rotating switch (7) to position 9.
- With the keys (3 and 4) you can change the value of the indication (0 up to 250 seconds).

Offset correction

As a factory setting, pressure transmitters are adjusted in a certain position. When the transmitter is mounted in another position, the measuring range is shifted.

- Ensure that the sensor is unpressurized.
- To carry out an offset correction, set the rotating switch (7) to position E (Offset correction). The display now indicates the actual sensor current in mA or the voltage in V.
- Push the plus and minus key (3 and 4) together. The measuring range is not modified, but completely shifted.
- Set the rotating switch (7) to position 0 (OPERATE). All adjusted values are transferred to an EEPROM-memory and saved. They remain there even in case of a probable voltage loss.

filling.

Stage 2

Activation of the pump changeover function

It is the task of a pump changeover function, in case of several pumps with the same function, to switch on the pump with the shortest working time and to switch off the pump with the longest working time.

This avoids overstress of the pumps and the lifetime of the pumps is increased considerably. This increases the reliability of the complete system and avoids failures.

This means that all relays where a pump changeover function is activated, are no more fixed coordinated to a certain switch point but are switched on or off dependent on the working time. VEGADIS 371 Ex selects for switch on the relay with the shortest working time and for switch off the relay with the longest working time.

Example (see fig. 4.3)

Two emptying pumps should empty a vessel when a certain level is reached. The first pump should switch on at 80 % filling.

When the level increases, a second pump should be switched on at 90 %.

Both pumps should be switched off again at 10 %

- Enter the values of the concerned relays in stage 1 as follows:

1	Relay 1 on	=	80,0
2	Relay 1 off	=	10,0
3	Relay 2 on	=	90,0
4	Relay 2 off	=	10,0
- Set the rotating switch to position 0 (Operate).
- Change to the menu stage 2, where you push the plus and the minus key together for approx. 3 seconds. The "VEGA"-logo flashes on the display.
- Set the rotating switch to position 1 (pump changeover function relay 1)
- Set the indication with one of the two keys to "on".
- Set the rotating switch to position 3 (pump changeover function relay 2)
- Set the indication with one of the two keys to "on".
- Set the rotating switch to position 0 (Operate) and push the plus and minus key together for approx. 3 seconds. The "VEGA"-logo no more flashes. The pump changeover function is

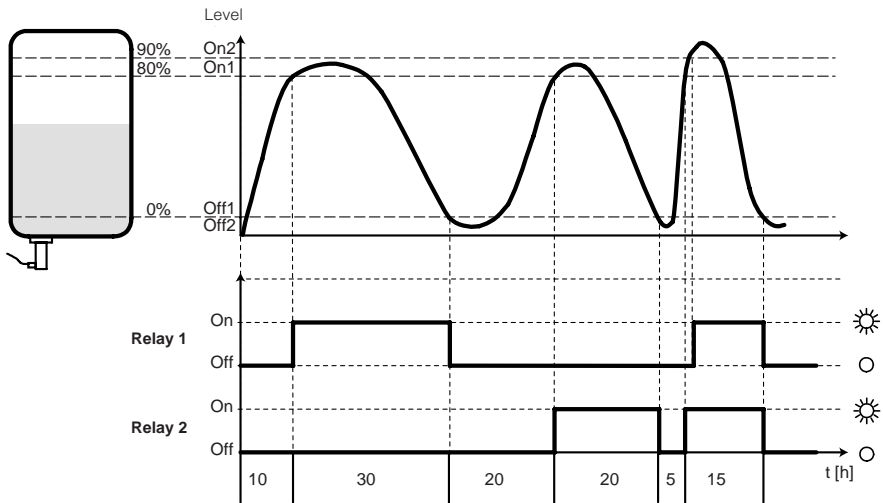

Fig. 4.3

Indication of the working times

When the pump changeover function of a relay is activated, the working times can be enquired (positions of the rotating switch 2, 4, 6, 8)

The working times of the relays which are coordinated to the pump changeover function are saved every 8 hours in the EEPROM, i.e. the data saved last remain even in case of power failure.

The working time is indicated in hours. The max. indication is 9999 hours (over 1 year). If this value is exceeded, the working time indication starts again at 0.

When you deactivate the pump changeover function of a relay, the working time indication is set to 0 and switched off.

When you carry out a reset, the pump changeover function for all relays is deactivated and the working time indication of all relays is reset to 0.

You can add or remove each relay individually to/from the pump changeover function. Any combination is possible.

The coordinated relays must all be operated in the same mode (A/B):

Mode A (overflow protection)

Switch on point < Switch off point

Switch on relay:

The relay with the shortest working time switches on.

Switch off relay :

The relay with the longest working time switches off.

Mode B (dry run protection)

Switch on point > Switch off point

Switch on relay:

The relay with the shortest working time switches on.

Switch off relay:

The relay with the longest working time switches off.

Note

The cover is lockable to protect the instrument against unauthorized adjustment.

now realised for both pumps (relay 1 and 2).

4.3 Mounting of the relay modules

Up to 2 relay modules with 2 output relays each can be mounted in VEGADIS 371. The mounting should be made by skilled staff. Ex-approved instruments must not be modified afterwards. When you want to retrofit VEGADIS 371 Ex, send the instrument to VEGA. With two relay modules totally 4 output relays are available.

- Switch off voltage supply.
- Loosen the front of the housing of VEGADIS 371 with a coin or a screwdriver. On the lower side of the housing there is a slot.
- Remove the front of the housing. You do not have to loosen the connection cable of the digital indication to mount the relay modules.
- Plug the first relay module carefully to module 1. Note that the pins are not bent (see fig. 4.4).
- Fasten the relay module with a small screwdriver.
- A sticker is attached to the relay where the terminal coordination is visible. Place this sticker to the instrument housing in front of the appropriate terminals.
- Connect the terminals of the relays.
- Switch the supply voltage on.
- Adjust the switch points so that you can use the

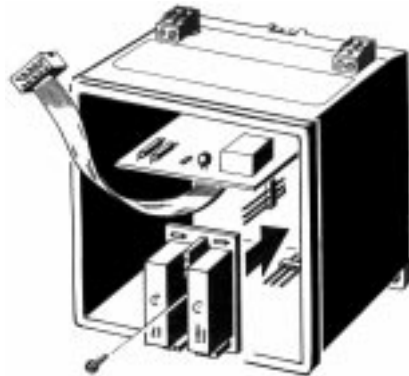

Fig. 4.4

relay module (see "4.2 Adjustment").

4.4 Reset

You can carry out a reset on VEGADIS 371. Hence all adjusted values are reset to the original factory setting.

- Interrupt the supply voltage of VEGADIS 371.
- Push the plus and minus key (3 and 4) together and hold the two keys pushed. Switch on the supply voltage. The display indicates "-RES-". The instrument carries out a reset.

VEGADIS 371 has the following factory setting (Reset-Default values).

Factory setting

Menu stage 1

- | | |
|---------------------------|---------------|
| - Relay switch on points | (10,0 %) |
| - Relay switch off points | (100,0 %) |
| - Display min. | (0) |
| - Display max. | (100) |
| - Decimal point | (1. position) |
| - Integration time | (0 s) |
| - Offset correction | (0 μ A) |
| - Current output | (4 ... 20 mA) |

Menu stage 2

- | | |
|----------------------------|-----------|
| - Pump changeover function | (OFF) |
| - Working time indication | (0 hours) |

5 Diagnosis

5.1 Simulation

The figures in brackets relate to the figures under "4.1 Indicating and adjustment elements".

- Set the rotating switch (7) to position F "Simulation". The actual measured value is taken over and flashes. The simulation is immediately active. Level changes are not indicated during simulation.
- With the keys (3 and 4) you can modify the value of the indication. You can adjust any requested value within the scaled range and hence test also the function of the current output and the mounted output relays.
- After the simulation is finished, you have to set the rotating switch (7) again to position 0 "OPERATE". Hence the simulation is interrupted and the actual measured value is indicated again.

5.2 Fault signals

The following fault signals can be indicated on the display:

Fault signal/Failure	Removal/Measure
E003 Failure during selfcheck	Relays deenergize (safe condition), current output 22 mA. Carry out a reset (see 4.4 Reset). Hence all adjusted values are reset to factory setting. When the failure occurs again, send the instrument to our repair department.
E014 Shortcircuit	Relays deenergize (safe condition), current output: 22 mA. Sensor current > 21 mA. Check the terminals and the connection line to the sensor.
E015 Line break	Relays deenergize (safe condition), current output: 22 mA. Sensor current < 3,6 mA. Check the terminals and the connection line to the sensor. Probably no sensor connected.
E017 Relay switch points Difference too small	The LED of the concerned relay flash. The concerned relay deenergizes (safe condition). Repeat the adjustment "4.2 Adjustment". Increase the difference between the two relay switch points.
E021 Indication scaling Difference too small	Repeat the adjustment "4.2 Adjustment". Increase the difference between the two indication values.
E116 Pumps in different mode	The LED of the concerned relay flashes. The concerned relay deenergizes (safe condition). Change to menu stage 1. Check the switching function of relay 1. Set all relays which are used for pump changeover function to the same switching function like relay 1 or deactivate the pump changeover function for these relays.

HiTECH

Technologies, Inc.

**A TECHNOLOGY FOR
EVERY LEVEL APPLICATION**

***HiTECH* Technologies, Inc.**

301 Oxford Valley Road - Building 505
Yardley, PA 19067-7706

Tel: 215. 321. 6012; Fax: 215. 321. 6067

Tech Support (Toll Free) 866-DrLevel or 888-NIVELCO

Email: info@DrLevel.com or info@hitechtech.com

Web Site: www.DrLevel.com or www.hitechtech.com

