

# Operating Instruction

Capacitive electrodes EL  
4 ... 20 mA - compact

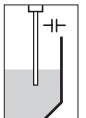
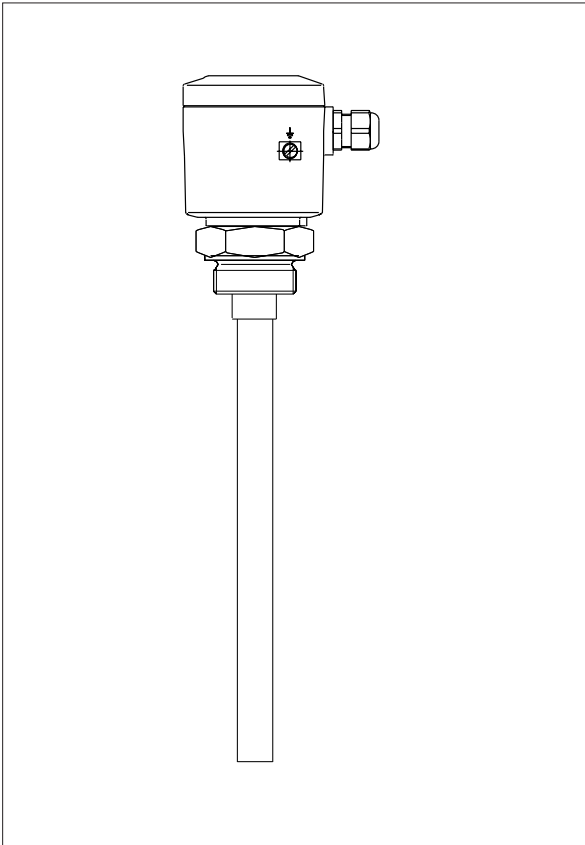

## **Safety information**

The described module must only be installed and operated as described in this operating instruction. Please note that other action can cause damage for which VEGA does not take responsibility.

**Contents**

Safety information .....	2
<b>1 Product description</b>	
1.1 Function and configuration .....	4
1.2 Types and versions .....	5
1.3 Technical data .....	7
1.4 Approvals .....	13
1.5 Dimensions .....	14
1.6 Type plate .....	16
<b>2 Mounting</b>	
2.1 Mounting instructions .....	17
<b>3 Electrical connection</b>	
3.1 Connection instructions .....	22
3.2 Wiring plan .....	22
<b>4 Set-up</b>	
4.1 General adjustment .....	26
4.2 Adjustment - Oscillators CAP E32 Ex and CAP E32 H Ex .....	27
4.3 Adjustment with VVO .....	30
4.4 Adjustment with HART®-handheld .....	36
<b>5 Diagnosis</b>	
5.1 Simulation .....	44
5.2 Maintenance .....	44
5.3 Repair .....	44
5.4 Failure removal .....	45

# 1 Product description

## 1.1 Function and configuration

Capacitive electrodes series EL detect levels of virtually any medium unaffected whether liquids, powders or pastes. This is also valid for adhesive products.

The electrode measures also the level capacitance and the ohmic resistance (admittance processing). Hence also problematic medium and solids with fluctuating humidity contents can be detected.

By the use of screening tubes and screen segments, inactive areas can be provided on the probe where pollution, condensation or permanent build-up do not influence the measuring result.

### Measuring principle

Electrode, medium and vessel wall form an electrical capacitor.

The capacitance of the capacitor is mainly influenced by three factors:

- distance of the electrode plates (a)
- size of the electrode plates (b)
- kind of dielectricum between the electrodes (c)

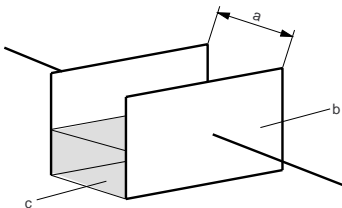

Fig. 1.1 Plate capacitor (schematic demonstration)

Electrode and vessel wall are the capacitor plates. The medium is the dielectricum. Due to the higher dielectric constant figure (DK-value) of the medium against air, the capacitance of the capacitor increases with raising covering of the electrode.

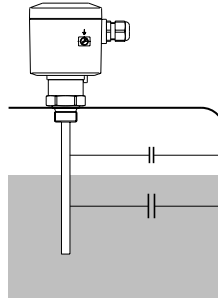

Fig. 1.2 Capacitance change with covered electrode

The capacitance change is processed by the oscillator and converted into a level proportional measured value. The measured value is provided analogue as standardized, floating 4 ... 20 mA-current signal, optionally also digitally with the HART®-communication protocol.

The sensor can be adjusted via the integral oscillator. Optionally the adjustment with HART®-handheld or PC with VVO-adjustment software is also possible.

With the continuous level measurement the appropriate level is continuously detected and converted into a level proportional signal which is either directly displayed or further processed.

You require a capacitive electrode series EL with oscillator CAP E32 Ex or CAP E32 H Ex.

The continuous measurement assumes a constant dielectric constant figure  $\epsilon_r$ , i.e. the medium should have steady features.

## 1.2 Types and versions

Version \ Type	EL 11*)	EL 21*)	EL 24*)	EL 29	EL 31*)	EL 33	EL 42*)	EL 52	EL 53
Continuous	•	•	•	•	•	•	•	•	•
Partly-insulated	•				•	•			
Fully-insulated		•	•	•			•	•	•
<b>Oscillators</b>									
CAP E32 EX	•	•	•	•	•	•	•	•	•
CAP E32 H EX	•	•	•	•	•	•	•	•	•
<b>Approvals</b>									
PTB 98 ATEX 2086	•	•	•		•		•		
PTB-no. Ex-98.E.2085	•	•	•		•		•		
Overfill protection acc. to WHG <sup>1)</sup>	•	•	•	•	•		•		
German Lloyd <sup>1)</sup>	•	•	•	•	•	•	•	•	•
Lloyds Register of Ship <sup>1)</sup>	•	•	•	•	•	•	•	•	•
American Bureau of Ship <sup>1)</sup>	•	•	•	•	•	•	•	•	•
Bureau Veritas <sup>1)</sup>	•	•	•	•	•	•	•	•	•
RINA <sup>1)</sup>	•	•	•	•	•	•	•	•	•
<b>Mechanical connection</b>									
G 1 A	•	•			•	•	•	•	
NPT 1 1/2"	•	•		•	•	•	•	•	•
G 1 1/2 A	•	•	•		•	•	•	•	•
Tri-Clamp 1 1/2"	•	•							
Tri-Clamp 2"	•	•	•			•		•	
Bolting DN 50	•	•	•						
Flange	•	•		•	•	•	•	•	•
Flange plated		•							
<b>Screw adapter</b>									
PP	•	•	•				•	•	
PTFE	•		•				•	•	
<b>Electrode material</b>									
Steel	•	•			•	•	•	•	•
StSt	• <sup>2)</sup>	• <sup>2)</sup>	• <sup>2)</sup>	• <sup>3)</sup>	• <sup>3)</sup>	• <sup>4)</sup>	• <sup>2)</sup>	• <sup>2)</sup>	

\*) also Ex 0

1) applied

2) 1.4435

3) 1.4571

4) 1.4401

5) For electrodes certified for Ex-Zone 0, only PTFE and FEP are approved as isolating material

Type Version	EL 11*)	EL 21*)	EL 24*)	EL 29	EL 31*)	EL 33	EL 42*)	EL 52	EL 53
<b>Isolation material<sup>5)</sup></b>									
PTFE	•	•			•	•	•	•	
PP	•				•				
PE/PA 12	•								
PFA		•							
FEP			•	•					
PE		•							
<b>Concentric tube</b>									
Steel	•	•	•						
StSt (1.4435)	•	•	•						
<b>Screening tube (option)</b>									
Steel	•	•	•		•	•	•	•	•
StSt	•	•	•		•	•	•	•	•
<b>Temperature adapter (option)</b>									
Steel	•	•			•	•		•	
StSt (1.4435)	•	•			•	•		•	
PA	•	•	•		•	•	•	•	
<b>Housing material</b>									
Plastic	•	•	•	•	•	•	•	•	•
Aluminium	•	•	•	•	•	•	•	•	•
<b>Others</b>									
Adapter <sup>6)</sup>	•	•			•			•	
Overtoltage protect.-option CB-2-36 (integrated)	•	•	•	•	•	•	•	•	•
Overtoltage arrester <sup>7)</sup>	•		•					•	•
Bending of electrode <sup>8)</sup>	•	• <sup>9)</sup>							

\*) also Ex 0

1) applied

2) 1.4435

3) 1.4571

4) 1.4401

5) For electrodes certified for Ex-Zone 0, PTFE and FEP are only approved as isolation material

6) For combustible liquids in pressurized vessels, e.g. liquid gas, ammonia

7) For high electrostatic discharges, e.g. plastic granules

8) Bending max. 90°

9) EL 21 only with PTFE at 3,2 mm isolation thickness

### 1.3 Technical data

#### Housing

Housing material	plastic PBT (Polyester) or Aluminium plastic coated
Protection	IP 66
- plastic housing	IP 66/67 (meets both protections)
- Aluminium housing	
Cable entry	1 piece M20 x 1,5
Terminals	for max. 1,5 mm <sup>2</sup> cross-section area of conductor

#### Mechanical connection

Material	galvanized steel (St 37), 1.4571 (StSt), Aluminium
Thread	G 1 1/2" A or 1 1/2" NPT
Flange	flange versions

#### Electrode

Material	EL 11	1.4435 (316 L)
	EL 21	steel (St 37)
	EL 31	1.4401 (316 L)
	EL 24, 42	1.4571 (316 L)
Length	- rod	max. 3 m
	- cable	max. 20 m
Isolation	see "Isolation materials"	
Max. tensile load (cable)		
- EL 31	3 KN	
- EL 33, 34, 42, 52, 53	3 KN	

#### Ambient conditions

Ambient temperature on the housing	-40°C ... +80°C
Medium temperature	see "Medium temperature and operating pressure"
Storage and transport temperature	-40°C ... +80°C
Operating pressure	see "Medium temperature and operating pressure"

#### Oscillator CAP E32 Ex, CAP E32 H Ex

Protection class	II
Overvoltage category	III
Meas. frequency	300 KHz
Capacitance ranges	0 ... 3000 pF

Supply voltage 12 ... 36 V DC  
 for Ex-applications note the stated permissible electrical connection values in the certificate.  
 Potential separation min. 500 V AC

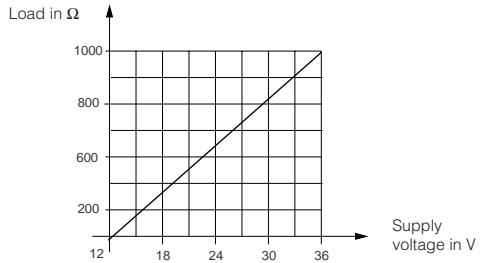

Accessory  
 Straining spring of 1.4571  
 - length approx. 185 mm (stressed)  
 - tensile load approx. 200 N

### Weight

Basic weight (e.g. EL 24) approx. 0,8 kg  
 Rod weight  
 ø 6 mm - 0,23 kg/m  
 ø 10 mm - 0,62 kg/m

### Oscillators in two-wire technology for capacitive electrodes EL

Type	Application	Meas. range	Frequency	Signal cond.instr.
CAP E32 Ex	Compact electronics 4 ... 20 mA for continuous level measurement, according to the principle of phase selective admittance processing Parameter adjustment via keys on the oscillator	0 - 3000 pF	300 KHz	not required
CAP E32 H Ex	Compact electronics 4 ... 20 mA for continuous level measurement, according to the principle of phase selective admittance processing Parameter adjustment via keys on the oscillator, VVO from V. 2.30 or HART®-handheld	0 - 3000 pF	300 KHz	not required

## Oscillator

The oscillator CAP E32 (H) Ex with the patented processing (phase selective admittance processing) extends the application range of capacitive level measurement technology. This function can be switched on, see 4 Set-up.

In conjunction with a fully insulated rod electrode, the oscillator compensates even strong conductive build-up.

Mounted in an individual rod or cable electrode type EL, this oscillator ensures also the exact measurement in solids with varying humidity contents.

The oscillator processes the measuring currents according to the phase position. Measuring currents with a defined phase shifting as they occur with build-up or humidity changes are filtered out.

fully and partly insulated electrodes react differently (see also "Fig. 1.3 Humidity change"). Whereby the measured value on fully insulated electrodes raises with steady level, the measured value on partly insulated electrodes drops.

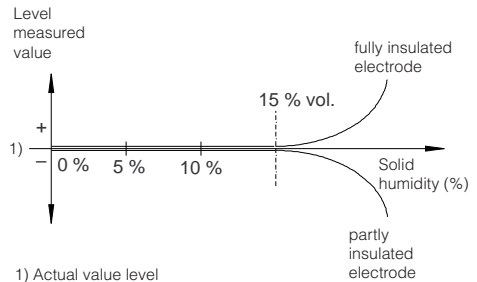

Fig. 1.3 Humidity change

## Humidity change

A humidity change in solids causes a change of the dielectric constant figure ( $\epsilon_r$ ). In parallel the ohmic value of the medium changes. Due to the change also a phase shifting of the measuring currents is caused.

With a capacitive measurement already lowest humidity changes cause measuring errors. Typical products are, e.g. sand, aggregate in the cement industry, hop or plastic granules (after drying).

When using the oscillator CAP E32 (H) Ex humidity changes of 15 % vol. do not influence the accuracy of the measurement. Even layering of product with different humidity do not play a role for the measuring accuracy. When the humidity contents exceeds 15 % vol.

## Medium temperature<sup>1)</sup> and operating pressure<sup>1)</sup>

The figures in the tables relate to the figures on this page. The statements on pressure are valid for screw connections G 1 1/2 A, NPT 1 1/2" and R 1 1/2".

Boltings DN 50 acc. to DIN 11 851 only up to max. 25 bar. With flange versions you have to note their nominal pressure.

All electrodes are also suitable for vacuum (-1 bar).

For electrodes certified for Ex-Zone 0, only PTFE and FEP are approved as isolating material.

### Mechanical connection, 1.4571

Isolation / Electrode type	PE	PP	PTFE	PE/PA 12	PFA	FEP
EL 11	-	1	3	-	-	-
EL 21	1	-	3	-	3	-
EL 21 (flange)	-	-	2	-	-	-
EL 24	-	-	-	-	-	2
EL 29	-	-	2	-	-	-
EL 31	-	1	3	-	-	-
EL 33	-	-	3	-	-	-
EL 42	-	-	2	-	-	-
EL 52	-	-	3	-	-	-
EL 53	-	-	-	1	-	-

### Mechanical connection, steel (St 37)

Isolation / Electrode type	PE	PP	PTFE	PE/PA 12	PFA	FEP
EL 11	-	4	6	-	-	-
EL 21	4	-	6	-	6	-
EL 21 (flange)	-	-	5	-	-	-
EL 24	-	-	-	-	-	5
EL 31	-	4	6	-	-	-
EL 33	-	-	6	-	-	-
EL 42	-	-	5	-	-	-
EL 52	-	-	6	-	-	-
EL 53	-	-	-	4	-	-

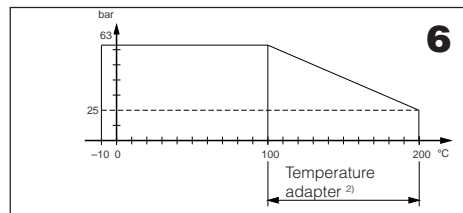
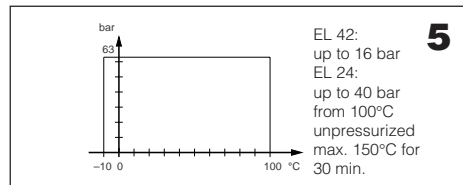
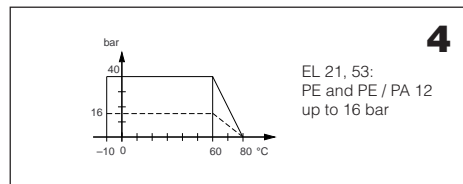
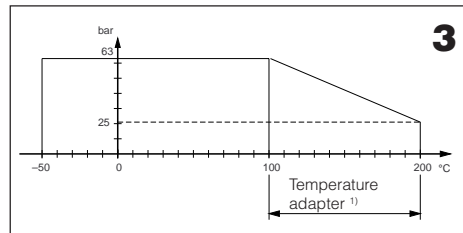
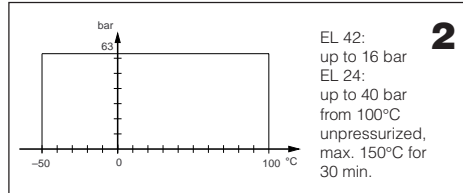
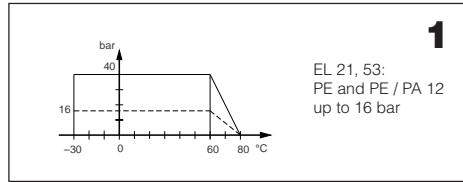

<sup>1)</sup> Temperature adapter of PA up to 150°C, from 100°C unpressurized

**Mechanical connection, Aluminium**

Isolation / Electrode type	PE	PP	PTFE	PE/PA 12	PFA
EL 11	-	7	8	-	-
EL 21	7	-	8	-	8
EL 31	-	7	8	-	-
EL 33	-	-	8	-	-
EL 42	-	-	8	-	-
EL 52	-	-	8	-	-
EL 53	-	-	-	7	-

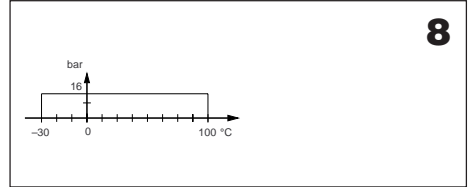
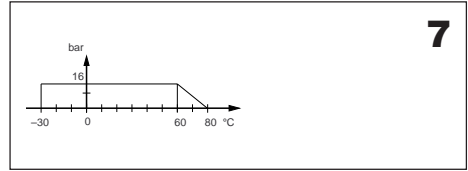

**Mechanical connection, PP, PVC, PTFE, screwed adapter**

Isolation / Electrode type	FEP	PP	PTFE
EL 29	10	10	10

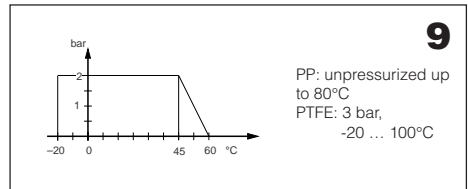

1) For Ex-applications the permissible temperatures and pressures stated in the certificate must be noted. Additionally note the table on the following page.  
 2) Temperature adapter of PA up to 150°C, from 100°C unpressurized

**Electronics temperature**

The following medium and ambient temperatures must be kept, so that the limit temperature on the electronics is not exceeded.

**Temperature class T4 (or no Ex)**

**Without temperature adapter**

- medium temperature -40°C ... +135°C
- ambient temperature<sup>1)</sup> -40°C ... +90°C

**Temperature class T3**

**With temperature adapter**

			Plastic housing		Metal housing	
Medium temperature	-40°C ...	180°C	200°C	150°C	175°C	200°C
Ambient temperature <sup>1)</sup>	-40°C ...	80°C	75°C	80°C	69°C	58°C

1) Ambient temperature on oscillator

## 1.4 Approvals

### Explosion protection

Only certified capacitive electrodes EL\*\* Ex 0 must be used in hazardous areas with combustible gases, vapours or fog.

Capacitive electrodes EL\*\* Ex 0 are suitable for the use in hazardous areas of zone 1 and zone 0.

Proof for the explosion protection of these instruments is the EC-type approval and the conformity certificate possibly with national zone 0 - annex issued by the approval authority. These documents are generally attached to the instruments.

When the capacitive electrodes are mounted and operated in hazardous areas, the Ex-installation regulations must be noted.

The information and regulations of the supplied certificates (EC-type approval, conformity certificate) of the capacitive electrodes as well as of the appropriate instrument (signal conditioning instrument, separator, safety barrier) must be noted.

- The mounting of Ex-systems must be generally carried out by skilled staff.
- The capacitive electrodes must be powered from an intrinsically safe circuit; the permissible electrical values are stated in the appropriate certificate.
- Capacitive electrodes with electrostatically chargeable plastic parts are provided with a warning label informing about measures which must be taken to avoid dangers caused by electrostatic discharges. Note the contents of the warning label.
- The explosion protection of the instrument used is only ensured when the limit temperatures stated in the certificate are not exceeded.
- In case of danger due to oscillation or vibration, the appropriate parts of the capacitive electrodes must be protected.
- After shortening of the electrode cable it must be noted that the weight is sufficiently secured by means of pins.

### Overfill protection acc. to WHG

The information and regulations of the supplied type approvals must be noted when a capacitive electrode is used as overfill protection for vessels storing water endangering liquids. The general type approval must be available on site.

Electrodes must be only used in such liquids against which the materials of the wetted parts of the capacitive electrodes are sufficiently chemically resistant.

### Ship approvals

For the use on ships, type approval certificates are available of several ship classification authorities (GL, LRS, ABS, BV, RINA).

### CE-approval

The capacitive electrodes type EL meet the protective regulations of EMVG (89/336/EWG) and NSR (72/23/EWG). The conformity has been judged acc. to the following standards:

EMVG	Emission	EN 50 081 - 1
	Susceptibility	EN 50 082 - 2
NSR		EN 61 010 - 1

### Zone 2

According to DIN VDE 0165, instruments can be used in hazardous areas of zone 2 without approval; they must meet the requirements in section 6.3 of this VDE. The compliance of the instruments with these requirements is confirmed by Messrs. VEGA in a manufacturer declaration.

**1.5 Dimensions**

**Dimensions of the capacitive electrodes type EL ... Ex 0**

**Type EL 11**  
**(partly insulated)**  
**(Ex 0)**

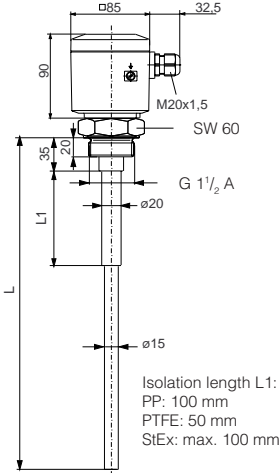

L (min. 100 mm, max. 4000 mm)

**Type EL 21 (fully insulated)**  
**(Ex 0)**

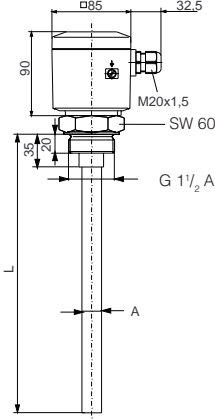

L (min. 100 mm, max. 4000 mm)

**Type EL 24 (fully insulated, for adhesive products)**  
**(Ex 0)**

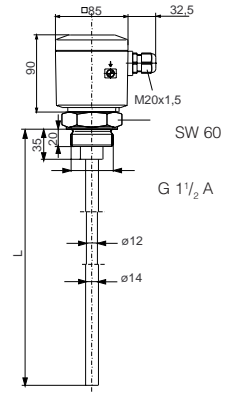

L (min. 120 mm, max. 4000 mm)

Isolation	A
	outer-ø
PE 2,0 mm	20 mm
PTFE 2,0 mm	20 mm
PTFE 3,2 mm	16 mm
PFA 2,0 mm	20 mm

**Type EL 29**  
**(fully insulated)**

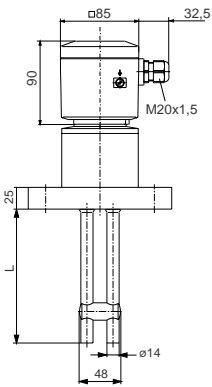

L (min. 120, max. 3000 mm)

**Type EL 31 (partly insulated)**  
**(Ex 0)**

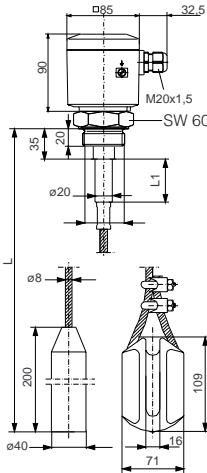

L (min. 400 mm, max. 25000 mm)

Isolation length L1:

PP: 100 mm  
PTFE: 50 mm  
StEx: max. 100 mm

**Type EL 42 (fully insulated)**  
**(Ex 0)**

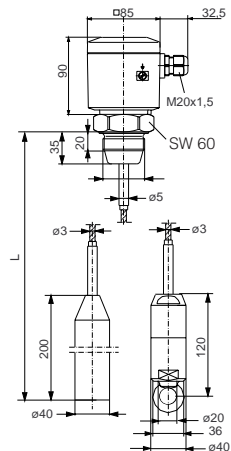

L (min. 400 mm, max. 25000 mm)

**Type EL 52 (fully insulated)**

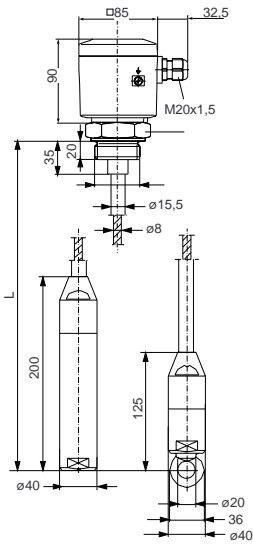

L (min. 400 mm, max. 25000 mm)

**Type EL 53 (fully insulated)**

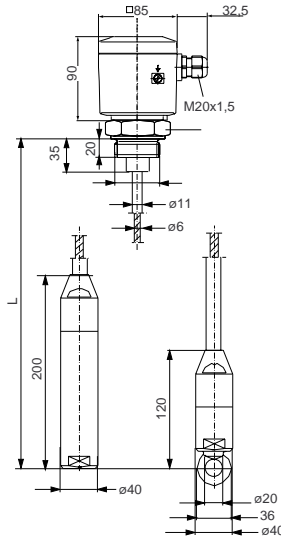

L (min. 400 mm, max. 25000 mm)

**Housing**

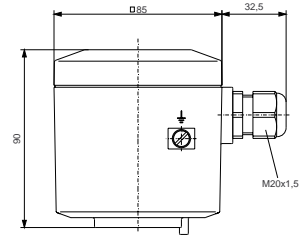

Housing of plastic / Aluminium

**Screwed adapter of PP or PTFE**

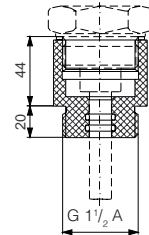

**Temperature adapter**

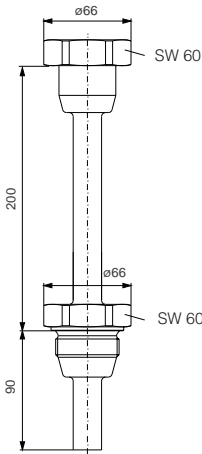

of galvanized steel or 1.4571

**Temperature adapter**

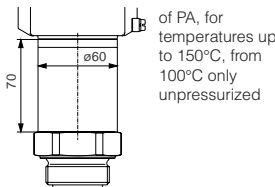

**Adapter**

for combustible liquids in pressurized vessels, e.g. liquid gas, ammonia

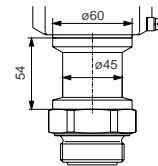

**Concentric tube**

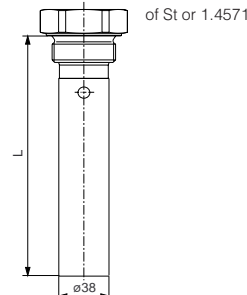

**Screening tube**

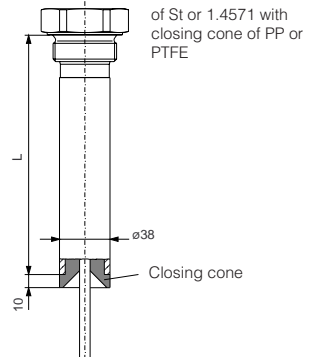

## 1.6 Type plate

Before mounting and electrical connection please check if you use the suitable instrument. Therefore note the type plate which is located as follows:

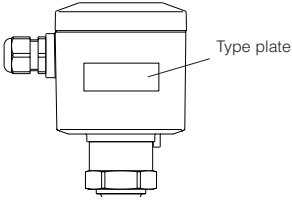

The type plate contains important data required for mounting and connection. The configuration and components of the type plate are hence explained in the following example.

### Configuration of the type plate (example)

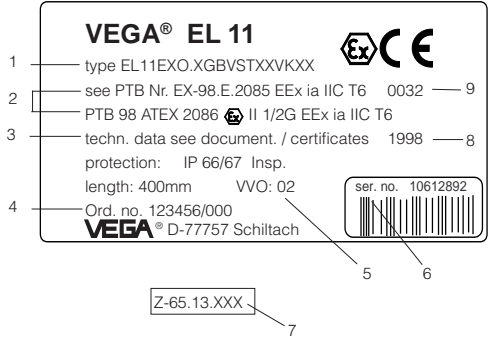

- 1 Master data of the order no.
- 2 Ex-certification number  
Explosion protection version - note the information and regulations of the certificate
- 3 Data of the electronics / Approvals
- 4 No. of the order confirmation /Pos.-no.
- 5 Number of the electrode type
- 6 Serial number
- 7 Test mark when used as part of an overfill protection for vessels storing water endangering liquids - note the information and regulations in the general type approval
- 8 Manufacturing year
- 9 Number of the test authority

#### Order code

Detailed information on the order you will find in the "Product Information Capacitive" or in the "VEGA-Pricelist".

## 2 Mounting

### 2.1 Mounting instructions

#### General

Different mediums and requirements to the measurement require various installations. Hence the following instructions should be noted.

#### Lateral load

Note that the electrode is not subjected to strong lateral forces. Mount the electrode in a position in the vessel where no interfering influences such as e.g. stirrers, filling opening etc. occur. This is mainly valid for very long rod and cable electrodes.

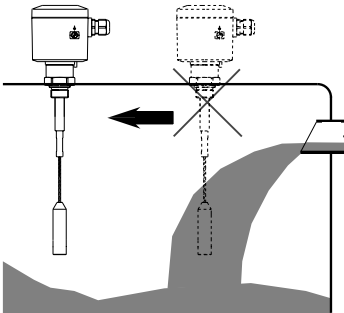

Fig. 2.1 Lateral load

#### Extraction forces

In case of strong extraction forces e.g. during filling or settling of solids, high tensile loads can be caused.

In these cases use for short measuring distances a rod electrode, as a rod is generally more stable. If due to the length or the mounting position a cable electrode should be necessary, the electrode should not be strained, but only equipped with a gravity weight as then the cable can more easily follow the product movements. Note that the electrode cable does not touch the vessel wall.

#### Pressure

In case of gauge or low pressure in the vessel, the mounting boss must be sealed on the thread. Use the attached seal ring. Check if the seal ring is resistant against the medium.

Isolating measures such as e.g. the covering of the thread with Teflon tape can interrupt the electrical connection in case of metal vessels. Hence earth the electrode on the vessel.

**Shortening of the electrode**

The dimensions of fully insulated electrodes are fixed and must hence not be modified. Each modification will destroy the instrument.

Partly insulated cable or rod electrodes can be shortened afterwards.

The electrode basic capacitance is automatically compensated during adjustment. It is hence possible to shorten the electrodes individually.

Cable electrode EL 31 can also be shortened afterwards (see fig. 2.2). Loosen the two pins on the gravity weight (hexagon) and remove the two pins. Pull the cable out of the gravity weight.

To avoid splicing of the steel cable (EL 31) during cutting, you have to tin the cable around the cutting position with a copper bit or strongly tighten the cable with a wire. Shorten the electrode cable with a metal cutting saw or a cutting-off wheel by the requested length.

Carry out the adjustment. The instruction is under "4.1 Adjustment".

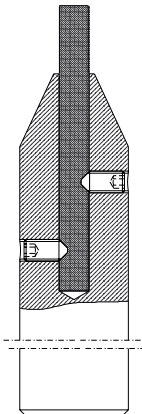

Fig. 2.2 Shortening of the electrode

**Filling opening**

Install the electrode such that it does not protrude directly into a strong filling stream. Should such an installation place be necessary, mount a suitable sheet above or in front of the electrode e.g. L 80 x 8 DIN 1028, etc.

**Humidity from outside**

To avoid humidity ingress, loop the connection line to the electrode housing on vertically installed electrodes directly behind the cable entry to the bottom so that rain and condensation water can drain off.

This is mainly valid for mounting outside, in areas where humidity must be expected (e.g. by cleaning processes) or on cooled or heated vessels (see fig. 2.3).

**Cable entries**

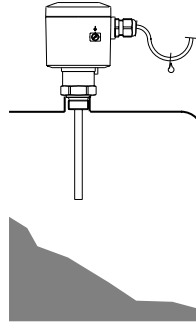

Fig. 2.3 Humidity

When mounting outside, on cooled vessels or in humid areas where cleaning is made e.g. with steam or high pressure, the seal of the cable entry is very important.

Use cable with a round cross-section area of conductor and tighten the cable entry. The cable entry is suitable for cable diameters of 5 mm to 9 mm.

**Metal vessels**

Note that the mechanical connection of the electrode is electrically conductive connected with the vessel to ensure sufficient earth.

Use conductive seals such as e.g. copper, lead etc. Isolating measures such as covering the thread with Teflon tape can interrupt the necessary electrical connection. In this case use the earth terminal on the housing to connect the electrode to the vessel wall.

### Non-conductive vessels

In non-conductive vessels, e.g. plastic tanks, the second pole of the capacitor must be provided separately, e.g. by a concentric tube or the use of a double rod electrode.

When using a standard electrode, a suitable earth plate is necessary. Hence provide a possibly large earth plate, e.g. wire braiding laminated into the vessel wall or metal foil which is glued to the vessel. Connect the earth plate with the earth terminal on the housing.

### Rod electrode

Mount the rod electrode such that the electrode protrudes into the vessel. When mounting in a tube or a socket, build-up can be caused which can influence the measurement. This is particularly the case with viscous or adhesive products.

### Cable electrodes in solids

Dependent on the kind of solid and position or kind of filling, the cable electrode can “float” despite of the gravity weight. The electrode (cable) is pushed by the solid to the vessel wall or to the top and wrong measured values are caused. This should be avoided with continuous level measurement.

In this case use a fixing weight or a fixing insulator to fasten the electrode (fig. 2.4).

When fastening the cable electrode avoid high tensile strengths. An appropriate fixing spring avoiding overloading of the cable is listed in our pricelist as accessory.

### Lateral installation

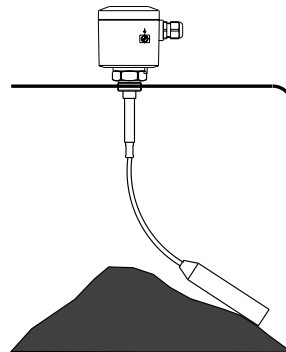

Fig. 2.4 Cable electrode in solids

With electrodes, delivering continuous measured values, the electrode must only be installed vertically. Should the installation from top not be possible, the electrodes can also be mounted laterally (fig. 2.5)

Under the accessory in our pricelist you find a screening tube and a closing cone or a bent rod electrode by which the electrode can be also mounted laterally. Choose the length (L) of the screening tube such that no product bridges can be caused between cable and vessel wall and that the electrode cable cannot touch the vessel wall due to product movements. Use a fixing weight or a fixing insulator.

### Material cone

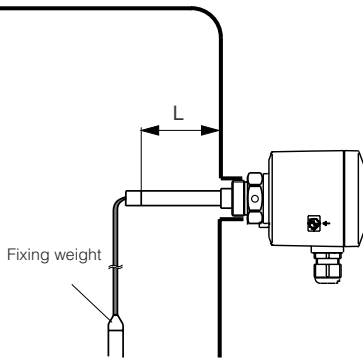

Fig. 2.5 Continuous electrodes

Note when installing the electrodes into the vessel, that material cones can be caused with solids which can change the switch point. We recommend to choose an installation place where the electrode detects an average value of the material cone.

emptying opening in the vessel, the electrode must be installed appropriately. To compensate the measuring errors caused by the material cone, you should install the electrode at a distance of  $\frac{d}{6}$  from the vessel wall.

According to the position of the filling and

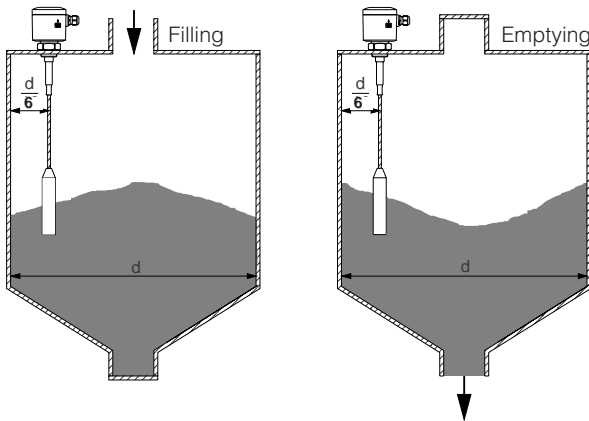

Fig. 2.6 Material cone, filling and emptying centered

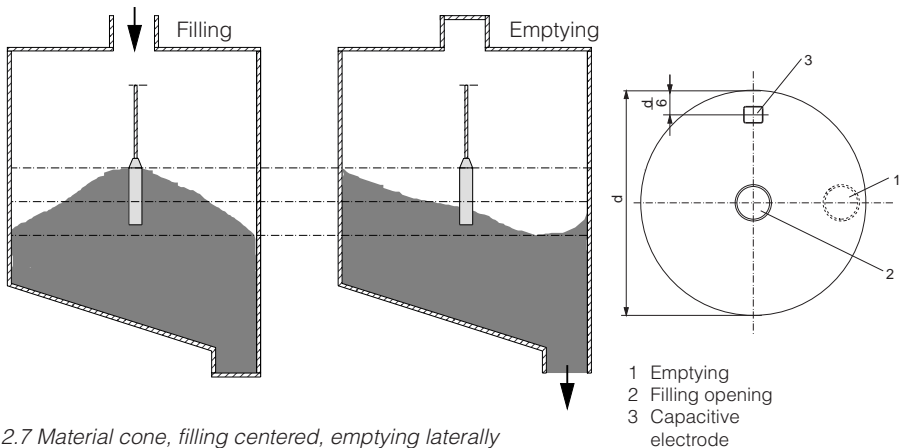

Fig. 2.7 Material cone, filling centered, emptying laterally

### 3 Electrical connection

#### 3.1 Connection instructions

**Note**

Switch off the power supply before starting connection work.

Connect supply voltage according to the following connection diagrams.

**Note**

If strong electromagnetic interferences have to be expected, we recommend to use screened cable. The screening of the cable should only be earthed at one sensor end (electrode).

Generally connect the electrode with vessel ground (PA). For this purpose there is a terminal laterally on the housing. This connection is additionally for the mass reference potential as well as to drain off electrostatic charges.

**Note**

The oscillator is independent of the electrode and can be exchanged locally.

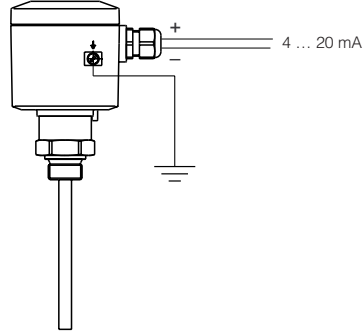

#### 3.2 Wiring plan

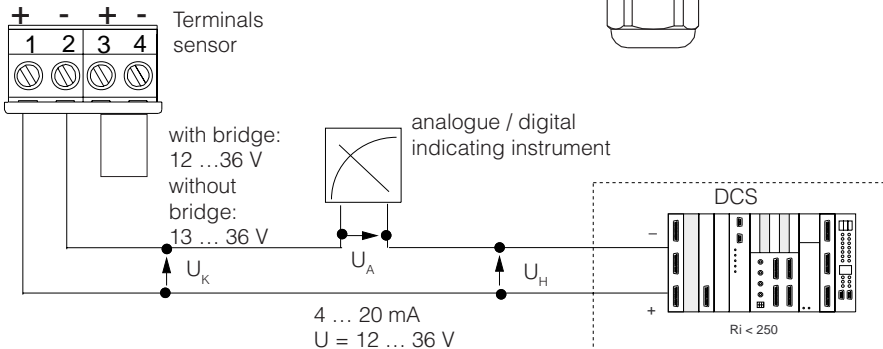
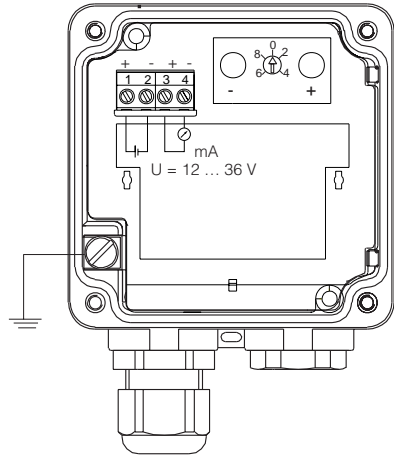

**Skilled staff**

Instruments operated in Ex-areas must only be mounted by skilled staff. They must note the mounting regulations and the supplied EC-type approvals and conformity certificates.

When capacitive electrodes are mounted on vessels which must be protected according to TRbF 100 no. 8, para.1 against inflammation due to lightning, they have to be equipped with the external overvoltage arrester type B 62-36 G or the internal overvoltage protection unit type CB 2-36.

**Vessel with cathodic corrosion protection**

**a) Capacitive electrodes with integral overvoltage protection unit type CB 2-36**

**(Ex)-area Zone 1**

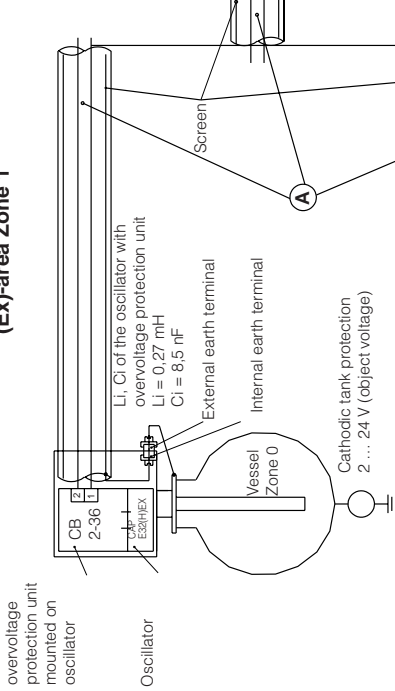

**Not (Ex)-area**

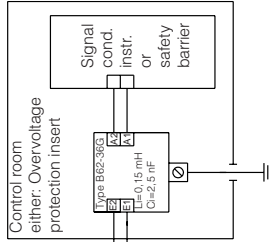

**b) Capacitive electrodes with external overvoltage protection unit**

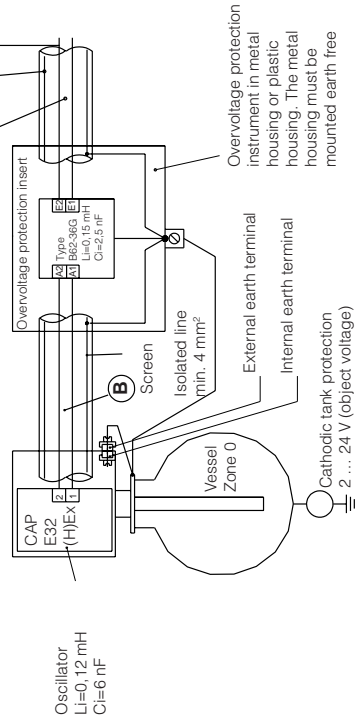

**A** Between control room and overvoltage protection system a suitable cable must be used, if necessary with metal cover or screen. Metal cover or screen - if necessary - must be only connected to the overvoltage protection system on the electrode side. The cable must have an outer isolation, test voltage of the cable A:  $\geq 500$  V AC

**B** Between overvoltage protection system and capacitive electrode a suitable cable with metal cover, screen or a suitable cable with metal protection tube must be used (metal cover or protection tube must not be earthed). Test voltage of the cable B:  $\geq 1500$  V AC

### Vessel without cathodic corrosion protection

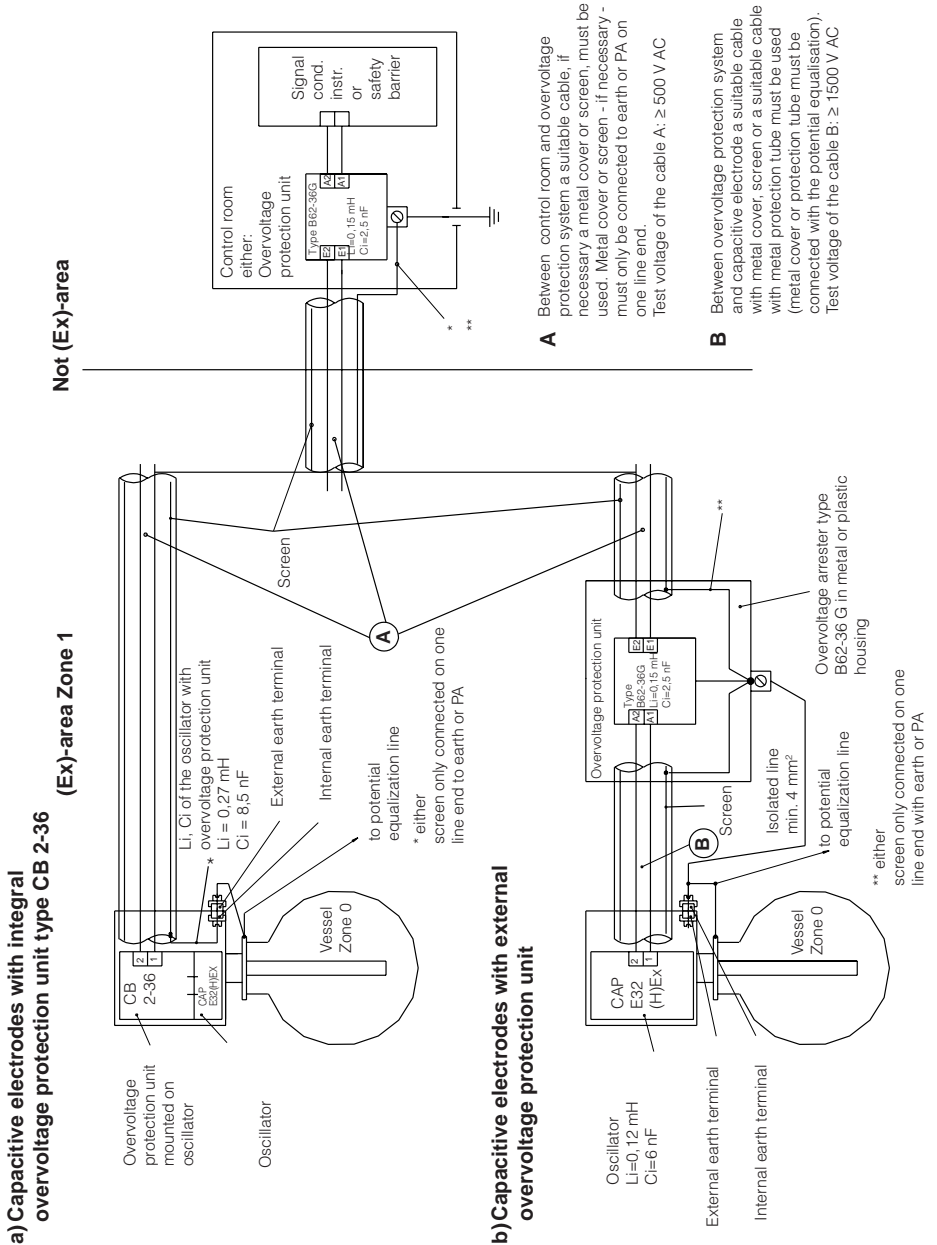

Not (Ex)-area

- A** Between control room and overvoltage protection system a suitable cable, if necessary a metal cover or screen, must be used. Metal cover or screen - if necessary - must only be connected to earth or PA on one line end.  
 Test voltage of the cable A:  $\geq 500$  V AC
- B** Between overvoltage protection system and capacitive electrode a suitable cable with metal cover, screen or a suitable cable with metal protection tube must be used (metal cover or protection tube must be connected with the potential equalisation).  
 Test voltage of the cable B:  $\geq 1500$  V AC

## 4 Set-up

### 4.1 General adjustment

The figures in brackets relate to the pictures under chapter "3 Electrical connection". With the set-up the electrode must be adjusted with the original medium.

In certain cases also a dry adjustment can be carried out.

The electrode can be adjusted in three different ways:

- with integrated oscillator
- with operating software VEGA Visual Operating (VVO from V. 2.30)
- with HART®-handheld

#### **CAP E 32 Ex**

Adjustment - directly on the oscillator.

#### **CAP E 32 H Ex**

Adjustment - directly on the oscillator  
 - via PC with adjustment program VVO<sup>1)</sup>  
 - via HART®- handheld

#### **Oscillator**

The capacitive electrodes EL can be directly adjusted on the oscillators CAP E32 Ex and CAP E32 H Ex.

All sensor basic functions can be carried out with the two keys and the rotating switch.

#### **PC with adjustment program VVO<sup>1)</sup>**

With the adjustment program VVO V. 2.30 (VEGA Visual Operating) on the PC you can adjust the capacitive electrode in conjunction with oscillator CAP E 32 H Ex very comfortably. Beside the sensor basic functions, also additional functions are available.

You require an interface adapter VEGACONNECT 2, which you can connect to any individual position of the signal line or directly on the sensor.

System requirements:

- IBM-compatible PC with a free standard interface. We recommend a PC with Pentium-processor with a clock frequency of 100 MHz.
- Memory: 16 MB
- Software requirements: Windows 95

#### **HART®-handheld**

The capacitive electrodes EL with oscillator CAP E32 H Ex are suitable for HART®-protocols and can be adjusted with a HART®-handheld. All relevant sensor functions are possible with the HART®-standard menus. A manufacturer specific DDD (Data-Device-Description) is not required.

1) When you want to adjust a sensor with the PC, you have to connect the PC-lines on the signal line outside the Ex-zone.  
 The intrinsic safety must be ensured with the connection. Use a suitable interface converter e.g. VEGACONNECT 2

## 4.2 Adjustment - Oscillators CAP E32 Ex and CAP E32 H Ex

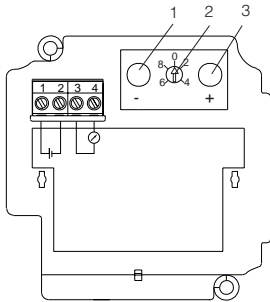

- 1 Minus switch
- 2 Rotating switch
- 3 Plus key

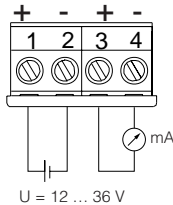

### Rotating switch (2)

With the rotating switch (10 steps) you choose the appropriate mode.

As soon as you continue to turn the rotating switch, the modified value is taken over.

- 0 Operate
- 1 Min. adjustment
- 2 Max. adjustment
- 3 Integration time
- 4 Reverse characteristics
- 5 Linearisation
- 6 Sensor optimization
- 7 Simulation current
- 8 Reset
- 9 Offset correction

### Plus and minus keys (3 and 1)

With the keys + and - you can modify the values of the parameters and choose out of several possibilities.

When you push both keys together, the value of the appropriately chosen function is reset to factory setting (except min./max. adjustment)

## Functional description

### 0 Operate

Basic position  
The instrument should be in this position during measurement. In mode Operate the actual measured value is transmitted. The plus and minus keys do not function.

### 1 Min. adjustment

This function is used to carry out the min. adjustment. Empty the vessel to min. level (0 % - level).

Push the plus and minus key together to set the current value for the actual level to 4 mA.

When you want to coordinate a certain current value to a known level, you can modify the current with the plus and minus keys. Every time you push the key, the current value will be changed in 10  $\mu$ A-steps. When you keep the key pushed, the value modifies with increasing speed.

Example: When you know that your vessel is filled to 10 %, then you can enter under min. adjustment a value of 5,6 mA.

$$20 \text{ mA} - 4 \text{ mA} = 16 \text{ mA}$$

$$16 \text{ mA} * 10\% = 1,6 \text{ mA}$$

$$1,6 \text{ mA} + 4 \text{ mA} = \underline{5,6 \text{ mA}}$$

It is recommended to connect an amperemeter, see 3.2 Electrical connection. You can monitor the current value during modification. When you keep the key pushed, the value changes automatically and with increasing speed. The difference between min. and max. adjustment should be at least 20% or 3,2 mA.

(+/-) set 4 mA

(+) increase current

(-) lower current

### 2 Max. adjustment

You use this function to carry out the max. adjustment. Fill the vessel to max. level (100 % level). Push the plus and minus key together. You can set the current value for the actual level to 20 mA.

When you want to coordinate a certain current

value to a known level, you can modify the current with the plus and minus keys. Each time you push the key, the current value changes in 10 µA-steps.

When you keep the key pushed, the value changes with raising speed.

Example: When you know that your vessel is filled to 90 % and should be filled to 100 %, then you can enter under the min. adjustment a value of 18,4 mA.

$$20 \text{ mA} - 4 \text{ mA} = 16 \text{ mA}$$

$$16 \text{ mA} * 90\% = 14,4 \text{ mA}$$

$$14,4 \text{ mA} + 4 \text{ mA} = \underline{18,4 \text{ mA}}$$

It is recommended to connect an amperemeter, see 3.2 Electrical connection. You can monitor the current value during modification. When you keep the key pushed, the value changes automatically and with increasing speed. The difference between min. and max. adjustment should be at least 20% or 3,2 mA.

- (+/-) set 20 mA
- (+) increase current
- (-) reduce current

**3 Integration time**

When you want to adjust the integration time (damping), set the rotating switch to position 3. With the plus and minus keys you can double or halve the value of the integration time step by step. As a standard feature an integration time of 0,5 seconds is adjusted. Count how often you have pushed the key, so that you can adjust the time correctly. If you are not sure, set the integration time to the preadjusted value of 0,5 s by pushing both keys together. Then repeat the adjustment.

After the adjusted integration time 63 % of the measured value change are available at the output.

The following integration times can be chosen on the oscillator: 0,5; 1; 2; 4; 8; 16; 32; 64; 128; 256 (s)

- (+/-) 0,5 s
- (+) increase time
- (-) reduce time

Example: To adjust an integration time of 8 seconds, you have to push the key "+" 4 times.

**4 Reverse characteristics**

With this function you can reverse the characteristics of the current output. The reverse characteristics is visible on the amperemeter.

- (+/-) 4 ... 20 mA
- (-) 4 ... 20 mA
- (+) 20 ... 4 mA

**5 Linearisation**

With this function you can activate the saved linearisation curve. As a standard feature the curve for cylindrical tank is saved. On CAP E 32 H you can enter other linearisation curves via VVO. In this case there is no preadjustment necessary on the oscillator.

- (+/-) linearisation off
- (+) linearisation on
- (-) linearisation off

**6 Sensor optimization**

**Mode 1 = Phase angle 90°**

Mode 1 is a pure capacitance measurement, the ohmic resistance is not considered in the measuring result.

Application:

- standard adjustment
- non-conductive liquids up to approx. 50 µS
- compensation of the resistance changes in liquids
- generally on partly insulated electrodes in liquids
- non-conductive solids without humidity contents
- with bad product earth
- with electrodes in conjunction with a concentric tube
- in non-conductive vessels with ground plate provided from outside

**Mode 2 = Phase angle 45°**

The capacitance and the ohmic resistance are

measured separately, the capacitance value is corrected by the calculation of the ohmic resistance so that measuring errors due to build-up or change in the product humidity are compensated.

Application:

- high conductivity products
- adhesive, conductive products
- solids with fluctuating humidity contents

For the use in conductive, adhesive liquids, the suitable electrode type EL 24 should be applied.

- (+/-) Mode 1 (90°)
- (+) Mode 1 (90°)
- (-) Mode 2 (45°)

### 7 Simulation current

With this function you can simulate the level. As soon as you set the rotating switch to position 7, the simulation is active. The actual current value of the actual level is taken over for simulation. With the plus and minus keys you can modify the current value in a range of 3,8 mA to 22 mA. Every time you push the key, the current value changes in 10  $\mu$ A-steps.

When you keep the key pushed, the value modifies automatically and with increasing speed.

- (+) increase current
- (-) reduce current

### 8 Reset

All adjusted values are reset to factory setting. Note that also the adjustment is deleted. Tag number, measurement loop designation etc. from the HART® or VVO-adjustment however remain unchanged.

- (+/-) Factory setting

### Factory setting

0 Operate ---

1 Min. adjustment	4 mA	at 0 pF
2 Max. adjustment	20 mA	at 3000 pF
3 Integration time	0,5 s	
4 Reverse characteristics		4 ... 20 mA
5 Linearisation		off
6 Sensor optimization	mode 1	(90°)
7 Simulation current	off	
8 Reset	---	
9 Offset correction	already saved values	remain

### 9 Offset correction

This function is required when an adjustment should be carried out in m. This is only possible with an oscillator CAP E 32 H Ex. With this function the initial capacitance in the electronics is saved. Requirement is that the electrode is mounted in the vessel and completely uncovered.

On electrodes with concentric tube this function is already carried out as factory setting as the vessel does not influence the measurement. The offset correction must only be repeated when exchanging the oscillator.

- (+/-) Initial capacitance is saved

### 4.3 Adjustment with VVO

When an oscillator CAP E 32 H Ex is mounted, the electrode can be also adjusted via a PC with adjustment software VVO (from version 2.30).

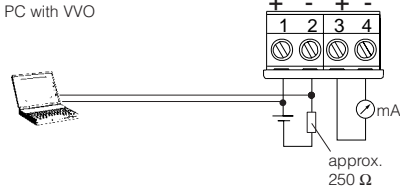

**Note**

When the resistance of the voltage supply is less than 250 Ω, a resistor must be looped into the signal/connection line during adjustment. The digital adjustment and communication signals would be shortcircuited via too small resistors e.g. of the supply current source or the processing system so that the sensor communication would not be ensured. The easiest way would be to connect the required adjustment resistor in parallel to the connection sockets of the HART@-handheld (see fig. 1).

- Switch on the power supply of the connected sensor.
- Start the adjustment software VVO (VEGA Visual Operating) on your PC.
- In the entrance window you choose with the arrow keys or the mouse the point *Planning* and click to *OK*.  
You should only choose *Planning* when you are authorized to modify instrument parameters. Otherwise choose *Operator* or *Maintenance*.
- In the window User identification you are asked for the name and the password.
- For set-up (*planning*) enter under name: *VEGA* and under password again: *VEGA*. It does not matter if you use capital or small letters.

VVO determines automatically the kind of the connected sensor and shows a little later to which sensor the connection exists.

When you get no sensor connection, check the following:

- The supply voltage must be at least 20 V.
- When VEGACONNECT 2 is directly connected to the sensor line, the load resistor must be 250 ... 350 Ohm.
- You have to use a VEGACONNECT 2. Older versions of VEGACONNECT are not compatible.

The following adjustment steps are described in their sequence and should be carried out in this sequence with the initial set-up.

Further information are stated in the operating instruction of the adjustment program VEGA Visual Operating (VVO).

### Configuration

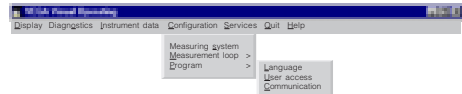

Under the menu point Configuration you can choose the following functions:

- Measuring system
- Measurement loop
- Program

The electrode is preadjusted by VEGA. The measuring system must only be re-configured when the oscillator is exchanged.

## Measuring system

In this sensor you can choose your appropriate electrode. You can see the electrode type on the type plate of the instrument.

Choose the correct electrode out of the list, e.g. EL 21 14 mm PTFE. In front of the listed electrodes you see the number of the electrode type. The number to your electrode is stated on the type plate. See also 1.6 Type plate. When your electrode is not stated in the list, choose "not configured". Push the button for saving to confirm the choice.



In this window you can carry out additionally a reset. All adjusted values are then reset to factory setting. Note that also the adjustment will be deleted.

Tag number, measurement loop designation etc. from the HART® or VVO-adjustment however remain unchanged.

## Factory Setting

0 Operate	---
1 Min. adjustment	4 mA at 0 pF
2 Max. adjustment	20 mA at 3000 pF
3 Integration time	0,5 s
4 Reverse characteristics	4 ... 20 mA
5 Linearisation	off
6 Sensor optimization	mode 1 (90°)
7 Simulation current	off
8 Reset	---
9 Offset correction	already saved values remain

## Measurement loop

In this window you can make the measurement loop designation.

### Measurement loop no. (Sensor-TAG)

In this field you can enter a measurement loop number, e.g. Tank 15 - 3. Max. 16 positions are available.

### Measurement loop description

In this field you can specify your measurement loop in detail, e.g. level measurement - cleaning solution.

Up to 80 positions can be entered.

## Application

For capacitive electrodes *Level measurement* is fixed adjusted and cannot be modified.

## Program

In this menu point you can modify the adjustments for the program.

## Language

Here you can modify the language of the program.



## User access

With this function you can modify the user name and the password or deactivate the password request.

**Communication**

You can determine the adjustments for data transmission.

**Options**

In this function, programm adjustments such as activate sound, backup etc. are available.

**Instrument data**



Under the menu point instrument data you can choose the function:

- Parameter adjustment.

**Parameter adjustment**

The following functions are available:

- adjustment
- conditioning
- outputs
- sensor optimization
- additional functions

**Adjustment - Min./Max. adjustment**

With this function you can adjust the electrode (min./max. adjustment).

You can choose if you want to carry out the adjustment with or without medium.

**Adjustment with medium**

Min. adjustment

There must be min. level in the vessel. When you push the button *Save*, the current value for the actual min. level is set to 4 mA. The read out of the sensor value in pF is also possible.

You can also coordinate a certain percentage value to a known level.

When you know e.g. that your vessel is filled to 10 %, this can be entered under min. adjustment.

Max. adjustment

There must be max. level in the vessel. When you push the button *Save*, the current value for the actual max. level is set to 20 mA. The sensor value can be also read out in pF.

You can also coordinate a certain percentage value to a known level.

The difference between min. and max. adjustment should be at least 20% or 3,2 mA.

**Adjustment without medium (dry adjustment)**



By means of the adjustment software VVO you can carry out under certain requirements an adjustment without medium.

The requirements for an adjustment in m are:  
In conductive medium:

- electrode is fully insulated

For conductivity the following criteria are valid:

	Mode 1 (90°)	Mode 2 (45°)
with conc.tube	> 50 µS/cm	>150 µS/cm
without conc. tube	>100 µS/cm	>300 µS/cm

In non-conductive medium:

- concentric tube electrode
- you know the DK-value of the medium

When you know already the electrode capacitance of a second similar measurement loop (same electrode, same installation conditions, same medium) you can also carry out the dry adjustment in pF.

First carry out an offset correction with uncovered electrode (only with adjustment in m: *Instrument data - Parameter adjustment - Additional functions*).

Move to function *Adjustment without medium*.

You can choose if you want to carry out the adjustment in pF or in m. When you have chosen the adjustment in m, you have to enter whether your medium is conductive or non-conductive. When the medium is non-conductive you must additionally enter the dielectric constant figure.

In the previous table you can see which criteria are valid for the conductivity with the capacitive measurement and if you have to choose *Conductive* or *Non-conductive*.

When you have chosen m, you can coordinate to the current or percentage values an appropriate value in metres.

Example

0% = 4,00 mA = 0,2 m  
100 % = 20,00 mA = 3,2 m

When you have chosen pF, you can coordinate to the current or percentage values an appropriate value in pico-farad

Example

0% = 4,00 mA = 97,2 pF  
100 % = 20,00 mA = 1428,0 pF

When you push the button *OK*, the values are taken over for adjustment.

### Conditioning

In this window the following functions are available:

- scaling
- linearisation
- integration time

### Scaling

With this command you can scale the measured value for your indication.

You can choose out of 16 volume, height and mass units or just dimensionless.

The indication values can be between -10000 and +10000.

### Linearisation

In this window you can linearize unlinear vessels such as e.g. cylindrical tanks.

The following linearisation curves are available:

- linear
- cylindrical tank
- spherical tank
- user programmable curve

On oscillator CAP E32 H you can enter under "user programmable curve" also own linearisation curves for special vessels, e.g. vertical cylindrical tanks with large conical outlet.

Push the button *Edit*. You can enter the value pairs (percentage value - volume value) for 32 index markers.

Push the button *Transfer*, to enquire further linearisation curves.

### Integration time

Choose this function when you want to adjust an integration time (damping).

The possible integration time is between 0,5 and 300 seconds. As a standard feature an integration time of 0,5 seconds is adjusted. For an integration time of 0,5 s you have to enter the value 0.

After the adjusted integration time, a measured value change of 63 % is available on the output.

### Output - Current output

In this window you can change the preadjustments for the current output. Push the button *Save* to transfer the modified values.

### Failure mode

The capacitive sensor delivers in case of failure generally 22 mA. This value cannot be modified.

### The current output corresponds to

The parameter of the current output is always percent with capacitive electrodes.

### Invert current output

With this function you can reverse the characteristics of the current output (4 ... 20 or 20 ... 4 mA).

### Sensor optimisation

In this window you can adjust the mode of the sensor.

Hence the phase angle of the phase selective admittance processing (PSA) is modified. "Mode 1" is preadjusted.

### Mode 1 = Phase angle 90°

Mode 1 is a pure capacitance measurement, the ohmic resistance is not considered in the measuring result.

Application:

- standard adjustment
- non-conductive liquids up to approx. 500  $\mu$ S
- compensation of resistance changes in liquids
- generally with partly insulated electrodes in liquids
- non-conductive solids without humidity contents
- in case of bad earth of the medium
- with electrodes in conjunction with a concentric tube
- in non-conductive vessels with earth plate provided from outside.

### Mode 2 = Phase angle 45°

The capacitance and the ohmic resistance are measured separately, the capacitance value is corrected by calculation with the ohmic resistance, so that measuring errors by conductive build-up or modifications of the product humidity are compensated.

Application:

- high conductivity products
- adhesive, conductive products
- solids with fluctuating humidity contents

### Additional functions

#### Offset correction

This function is required when an adjustment should be carried out in m. This is only possible in conjunction with oscillator CAP E 32 H Ex. With this function the initial capacitance is saved in the electronics. Requirement is that the electrode is mounted in the vessel and completely uncovered.

The offset correction is necessary when an adjustment should be carried out without medium.

On electrodes with concentric tube, this function is already carried out as factory setting as the vessel does not influence the measurement.

The offset correction must only be repeated when the oscillator is exchanged.

### Display



Under the menu point display you can choose the function:

- Display of measured value.

### Display of measured value

In this window the actual measured value is displayed digitally and as bargraph.

The upper bar shows the actual measured value in percent, pF or scaled in the appropriate unit.

The lower bar shows the actual sensor current value in mA.

## Diagnostics

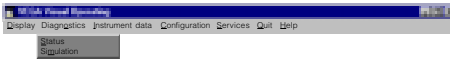

Under the menu point diagnostics you can choose the following functions.

- status
- simulation

### Status

This function is not available.

### Simulation

With this function you can simulate a level. Push the start button to activate the simulation. Shift the scrollbar to the requested current value or enter a certain current value. The scaled indication bar is modified in parallel. Push the button *Stop* to interrupt the simulation. When you quit the window *Simulation*, the simulation is automatically interrupted.

## Services

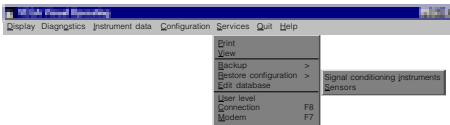

Under the menu point services you can choose the following functions:

- print
- view
- backup
- restore configuration
- edit database
- user level
- connection
- modem

## Print

With this function you can print a protocol with the adjustments of the sensor.

## View

With this function you can have the protocol with the sensor adjustments displayed.

## Backup - Sensors

In this window you can save the adjustments of the sensor in a database.

## Restore configuration - Sensors

In this window you can enquire the adjustments of the sensor from the database.

## Edit database

In this window you can edit the saved sensor data of the database.

## User level

In this window you can choose the user level. The following user levels are available:

- operator
- maintenance
- planning

### Operator

This user level is for the operator. Indication or print out of measured values and sensor data. For this level there is no password required.

### Maintenance

When you use the level maintenance, you can choose all functions except configuration. The password for this level is: VEGA.

### Planning

When you choose the level planning all functions are accessible. The passwords for the planning level are: VEGA - VEGA.

## Connection

With this function you can start a new connection. This function can also be activated with key F8.

**Modem**

This window enables the adjustments for data transmission with a modem. This function can also be activated with key F7. No special requirements necessary for the modem used.

**Note**

When the resistor of the supply voltage is less than 250 Ω, a resistor must be looped into the signal/connection line during adjustment. The digital adjustment and communication signals would be shortcircuited via too small resistors e.g. of the current source or the processing system so that the sensor communication would no more be ensured. The easiest way would be to connect the required resistor in parallel to the socket of the HART®-handheld (see fig. 1, page 38).

**4.4 Adjustment with HART®-handheld**

The capacitive electrodes EL with oscillator CAP E32 H Ex are suitable for HART®-protocols and can be adjusted with a HART®-handheld.

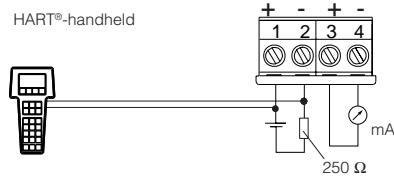

All relevant sensor functions can be carried out with the HART®-standard menus. A manufacturer specific DDD (Data-Device-Description) is not necessary. Connect the HART®-handheld to the signal line after you have connected the sensor to the supply voltage.

**Multidrop-operation**

With the HART®-handheld the Multidrop-operation can be chosen. Hence several HART®-sensors can be composed on one two-wire line.

The sensor provides beside the 4 ... 20 mA-signal also a digital (HART®) level signal.

- When you enter address 0 (factory setting), the sensors takes a level independent 4 ... 20 mA-current and delivers a digital (HART®) level signal. In this line e.g. also an indicating instrument (4 ... 20 mA) can be looped.
- When you enter an address from 1 to 15, the sensor takes permanently a current of 4 mA and delivers a digital (HART®) level signal.

**Burst-operation**

Normally the sensor signals the measured values to the processing unit only on request. When you switch on Burst-operation, the sensor signals the measured values without request.

### Connection to a VEGA-signal conditioning instrument

(fig. 3, page 38)

When you operate a sensor suitable for HART® on a VEGA-signal conditioning instrument, you have to provide the sensor connection on the signal conditioning instrument with a resistor of the following table for the duration of the HART®-adjustment.

VEGA-signal conditioning instrument	Rx
VEGAMET 513, 514, 515, 602 VEGATRENN 544 VEGATOR 521...527	50 ... 100 $\Omega$
VEGAMET 614 VEGADIS 371	no additional resistor required
VEGAMET 601	200 ... 250 $\Omega$
VEGASEL 643	150 ... 200 $\Omega$
VEGAMET 513 S4, 514 S4 515 S4	100 ... 150 $\Omega$

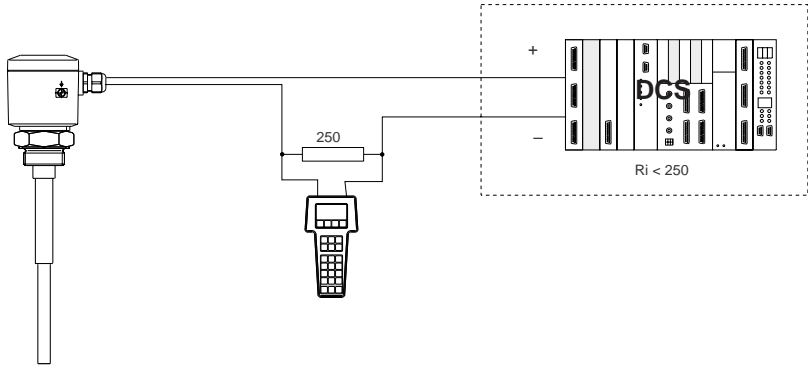

Fig. 1

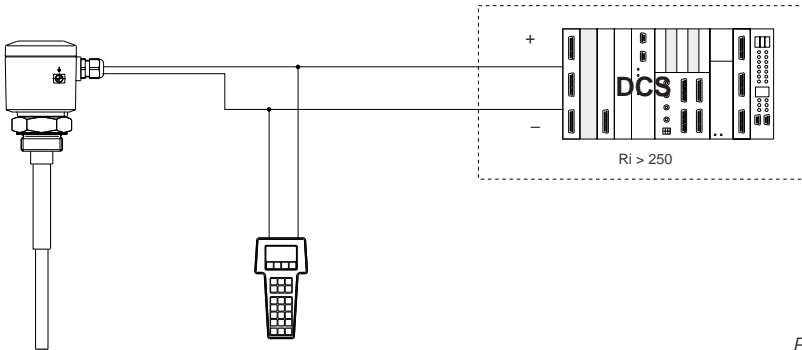

Fig. 2

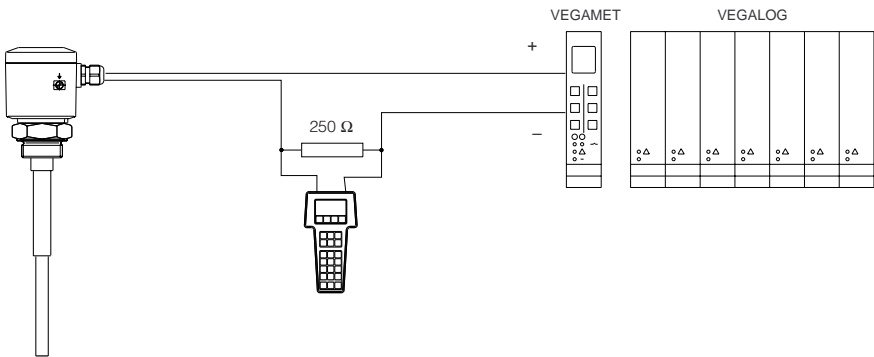

Fig. 3

## Adjustment steps

On the following pages you see the menu plan to the HART®-handheld in relation with capacitive electrodes.

The most important adjustment steps are marked in the menu plan with the figures A ... D.

General information to the HART®-handheld:

When you enter or modify parameters, you have to push the key "ENTER". Hence the adjustment is saved in the handheld but not in

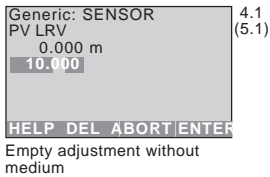

the sensor itself.

After you have pushed "ENTER", you have to push "SEND", to transfer the adjustment to the

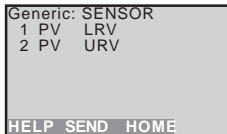

sensor.

After pushing of "SEND" a warning is displayed.

When you push "OK", the adjustment is

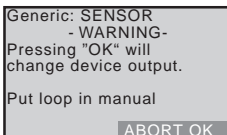

transmitted to the sensor.

Another safety enquiry asks you to switch over your system from manual to automatic

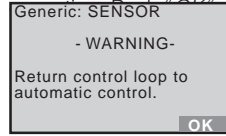

With "HOME" you reach again the initial menu.

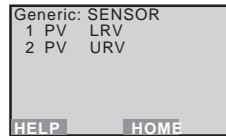

## HART®-menu plan

Switch on:

```

Hart Communicator
Self Test
in Progress

Firmware Rev: F2.2
Module Rev: 3.6
01992-96 FRSI
    
```

after approx.  
20 s

```

Generic: Sensor
Online(Generic)
1 Device setup
2 PV
3 PVAO
4 PVLRV
5 URV
HELP SAVE
    
```

Set-up the sensor in the sequence of the figures A, B, C and D (adjustment without medium).  
In case of adjustment with medium, set-up the sensor in the sequence A1, B1, C and D.

```

Generic: Sensor
Device setup
1 Process variables
2 Diag/Service
3 Basic setup
4 Detailed setup
5 Review
SAVE HOME
    
```

```

Generic: Sensor
Process variables
1 Snr 2,56 m
2 AI % rng
3 AO1
HELP SAVE HOME
    
```

```

Generic: Sensor
PV
2,56 m
HELP EXIT
    
```

```

Generic: Sensor
AO1
16.952 mA
HELP EXIT
    
```

```

Generic: Sensor
1 PV LRV
2 URV
HELP SEND HOME
    
```

**A**

```

Generic: Sensor
PV LRV
0.000 m
10.000
HELP DEL ESC ENTER
    
```

Empty adjustment  
without medium

**B**

```

Generic: Sensor
PV URV
100.000 m
90.300
HELP DEL ESC ENTER
    
```

Full  
adjustment  
without  
medium

continue like under A  
figure 4.1(5.1)

```

Generic: Sensor
1 PV LRV
2 URV
HELP SEND HOME
    
```

continue like under  
figure 4

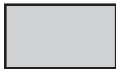

Important and  
necessary menu  
windows

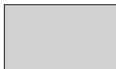

Less important  
menu windows



Not required,  
unimportant or blocked  
menu windows

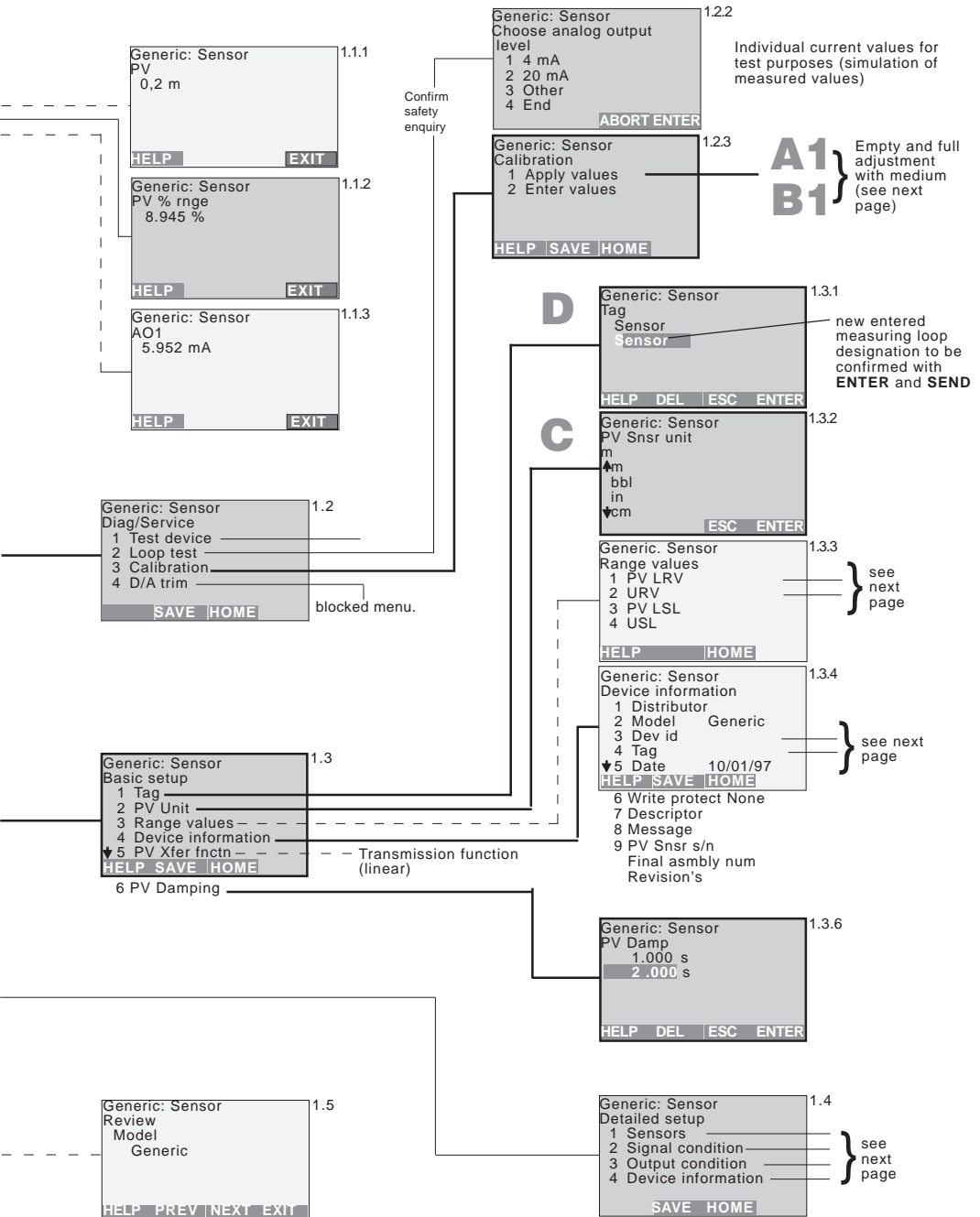

HART®-menu plan (continuation)

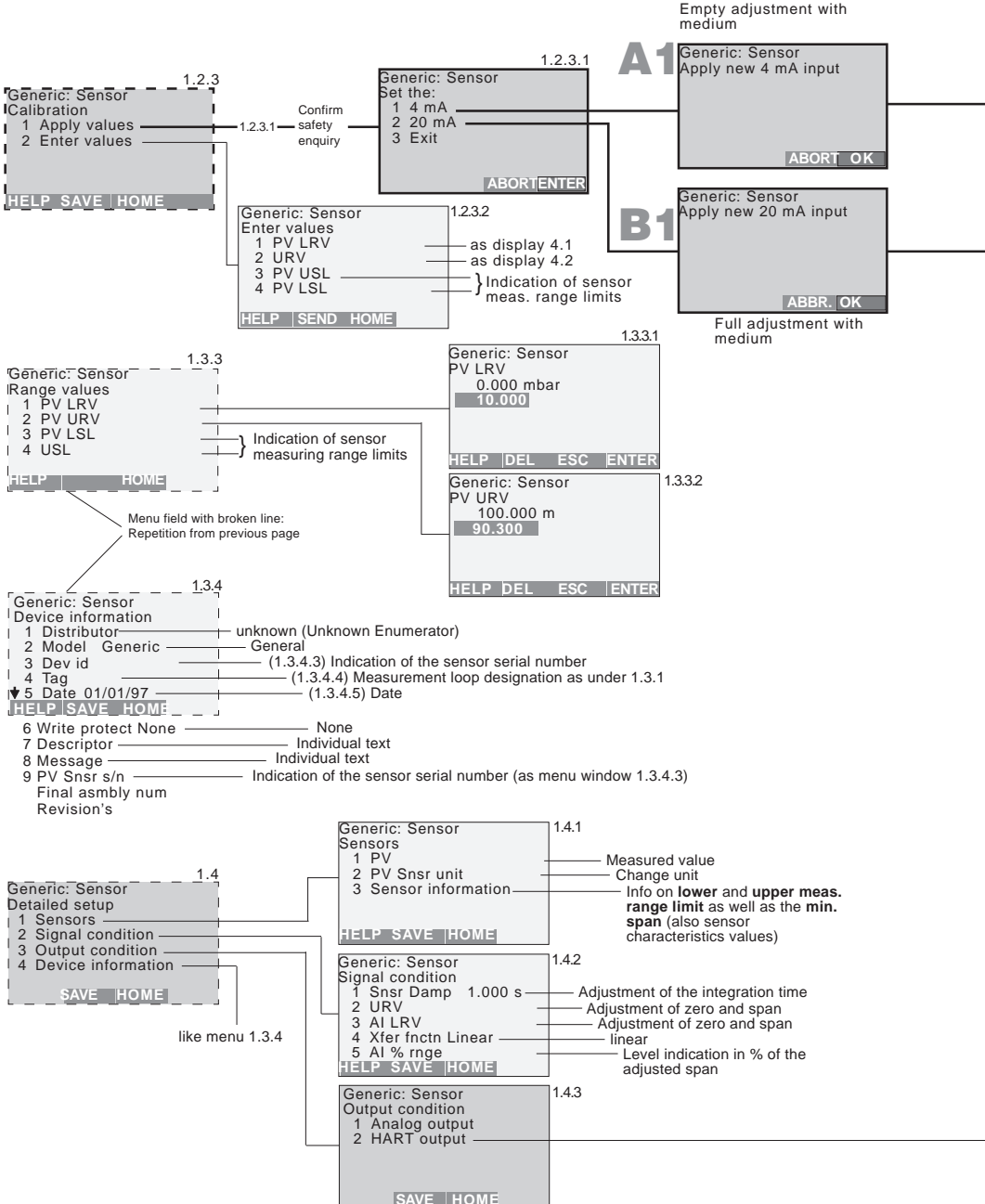

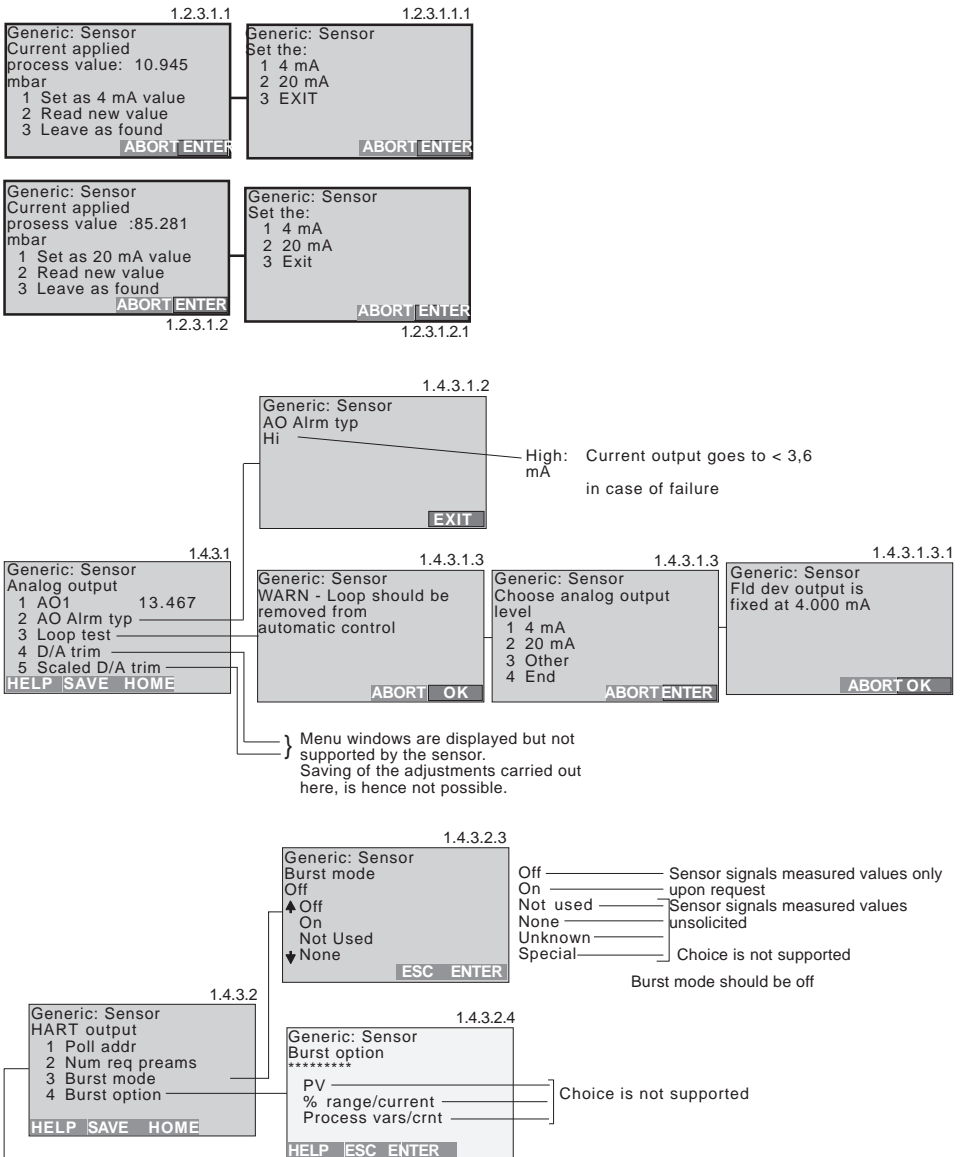

**Note:**

After adjustment of a parameter push "ENTER" and then "SEND".  
 Confirm the message to switch over the meas. circuit to manual operation with "OK".  
 Confirm the message to change over to automatic operation also with "OK".  
 Only then the adjustment is written in the sensor and is effective.

## 5 Diagnosis

### 5.1 Simulation

To simulate a certain filling, you can enquire the function simulation on the oscillator, in the adjustment program VVO or in the HART®-handheld.

Then you simulate a certain current. Note that connected instruments such as e.g. a DCS react according to their adjustment and trigger if necessary alarm functions or activate system functions.

### 5.2 Maintenance

The instrument is maintenance free.

### 5.3 Repair

Due to safety and guarantee reasons repair work beside the wiring must only be made by VEGA-staff.

In case of a defect, please return the appropriate instrument with a short description of the error to our repair department.

Failures are shortterm malfunctions of the instrument which are caused by wrong adjustment or defects on the sensor or the connection lines.

Failures, possible reasons and their removal are stated under "5.4 Failure removal".

## 5.4 Failure removal

### Failure

Current value  
 $\geq 22 \text{ mA}$

### Measure, failure removal

Check the sensor inputs on the following failures:

- shortcircuit on the input
- sensor not correctly connected
- sensor line interrupted
- supply voltage too low or too high

Measure the current on the connection line to the sensor.

The terminal voltage on the sensor in standard condition is at least 12 V.

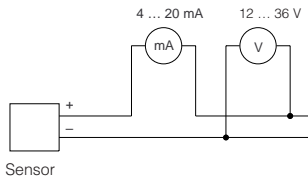

Note with Ex-systems that the Ex-protection is not influenced by the measuring instruments.

Current value  $> 22 \text{ mA}$

- Check all connections and the connection line to the sensor.
- Loosen the two small screws with a screwdriver and remove the oscillator out of the plug connection.
- Measure the current.
  - When the current value remains  $> 22 \text{ mA}$ , the oscillator is defect. Exchange the oscillator.
  - When the current value is  $< 22 \text{ mA}$ , the electrode is defect. Return the electrode for repair.

**Failure**

Sensor defect,  
measurement does  
not react to level  
changes

**Measures, failure removal**

Test of the internal connections:

- Loosen the 4 screws of the housing cover with a screwdriver and remove the housing cover.
- Loosen the two small screws with a screwdriver and pull the oscillator out of the housing.
- Measure with an Ohm-Meter (range  $M\Omega$ ) the resistance values between the following contacts:

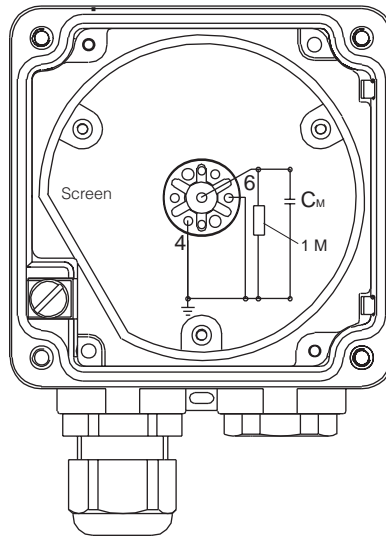

$C_M$  - Meas. capacitor

**Contact 4 against middle pin (1)**

The resistor must be  $1 M\Omega$ .

If the resistor is less, this means humidity in the housing or a failure in the electrode isolation. A possible reason could be a not isolated electrode which is used in conductive (humid) product.

If the resistor is higher or if the connection is interrupted, the reason is mainly a bonding failure in the adapter plate or a defect resistor due to strong electrostatic discharge.

In both cases the electrode must be repaired at VEGA.

**VVO-  
failure message**  
Meas. value invalid

#### **Contact 4 against vessel**

The connection between contact 4 and the metal vessel (not instrument hexagon or electrode flange) should be as good as possible. Measure with an ohmmeter (range very low) the resistance value between contact 4 and the vessel.

- Shortcircuit (0 ... 3  $\Omega$ ), optimum connection
- Resistance > 3  $\Omega$ 
  - corrosion on the mounting boss or flange
  - probably the mounting boss was covered with Teflon tape or similar

Check the connection to the vessel. If there is no connection, you can connect a line from the earth terminal outside to the vessel.

Note that coated flanges must be in any case connected via the earth terminal to the vessel.

#### **Contact 4 against 6**

In case of values > 3  $\Omega$  there is a defect.

When you cannot find a failure in the electrode, than exchange the oscillator against a similar replacement type (if available) or send the electrode for repair to VEGA.

After insertion of the new electronics, carry out an adjustment. See 4 Set-up.

#### **Measured value invalid**

The actual measured value is not within the valid measuring range.

Reasons can be e.g. extreme modifications of the dielectric constant figure or wrong adjustments.

Modify the actual measuring conditions.

**VVO-  
failure message**  
Instrument failure

**Instrument failure**

No failure detected on the sensor.

Possible reasons are:

- supply voltage outside the tolerance
  - defect oscillator
  - damage of the electrode or the isolation
  - electrode shortcircuited with the vessel wall
- 
- Separate the sensor from the supply voltage and then connect voltage again (cold start).
  - If the fault signal does not extinguish, check the sensor line and the correct supply voltage.
  - If the fault signal does not extinguish, check the sensor on damages. If you cannot detect any failure, call our service department.







# ***HiTECH***

Technologies, Inc.

**A TECHNOLOGY FOR  
EVERY LEVEL APPLICATION**

## ***HiTECH* Technologies, Inc.**

---

301 Oxford Valley Road - Building 505  
Yardley, PA 19067-7706

Tel: 215. 321. 6012; Fax: 215. 321. 6067

Tech Support (Toll Free) 866-DrLevel or 888-NIVELCO

Email: [info@DrLevel.com](mailto:info@DrLevel.com) or [info@hitechtech.com](mailto:info@hitechtech.com)

Web Site: [www.DrLevel.com](http://www.DrLevel.com) or [www.hitechtech.com](http://www.hitechtech.com)

---

