

VEGA

Operating Instructions

VEGAPULS 63

4 ... 20 mA/HART

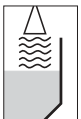

Contents

1 About this document

1.1	Function	4
1.2	Target group	4
1.3	Symbolism used	4

2 For your safety

2.1	Authorised personnel	5
2.2	Appropriate use	5
2.3	Warning about misuse	5
2.4	General safety instructions	5
2.5	CE conformity	5
2.6	Compatibility acc. to NAMUR NE 53	6
2.7	FCC conformity (only for USA/Canada)	6
2.8	Safety information for Ex areas	6
2.9	Environmental instructions	7

3 Product description

3.1	Configuration	8
3.2	Principle of operation	8
3.3	Adjustment	9
3.4	Storage and transport	9

4 Mounting

4.1	General instructions	10
4.2	Mounting information	11

5 Connecting to power supply

5.1	Preparing the connection	18
5.2	Connection procedure	19
5.3	Wiring plans, single chamber housing	20
5.4	Wiring plans, double chamber housing	21
5.5	Wiring plans, double chamber housing Exd	24
5.6	Wiring plans, version IP 66/IP 68, 1 bar	26
5.7	Switch on phase	26

6 Setup with the indicating and adjustment module PLICSCOM

6.1	Short description	27
6.2	Installing the indicating and adjustment module PLICSCOM	27
6.3	Adjustment system	29
6.4	Setup procedure	30
6.5	Menu schematic	34

7	Setup with PACTware™	
7.1	Connecting the PC	37
7.2	Parameter adjustment with PACTware™.	38
8	Maintenance and fault rectification	
8.1	Maintenance	40
8.2	Fault rectification	40
8.3	Exchanging the electronics.	42
8.4	Instrument repair	42
9	Dismounting	
9.1	Dismounting procedure	44
9.2	Disposal	44
10	Supplement	
10.1	Technical data.	45
10.2	Dimensions	52
10.3	Certificates	55

1 About this document

1.1 Function

This operating instructions manual has all the information you need for quick setup and safe operation of VEGAPULS 63. Please read this manual before you start setup.

1.2 Target group

This operating instructions manual is directed to trained personnel. The contents of this manual should be made available to these personnel and put into practice by them.

1.3 Symbolism used



Information, tip, note

This symbol indicates helpful additional information.



Caution, warning, danger

This symbol informs you of a dangerous situation that could occur. Ignoring this cautionary note can impair the person and/or the instrument.



Ex applications

This symbol indicates special instructions for Ex applications.



List

The dot set in front indicates a list with no implied sequence.



Action

This arrow indicates a single action.



Sequence

Numbers set in front indicate successive steps in a procedure.

2 For your safety

2.1 Authorised personnel

All operations described in this operating instructions manual must be carried out only by trained specialist personnel authorised by the operator. For safety and warranty reasons, any internal work on the instruments must be carried out only by personnel authorised by the manufacturer.

2.2 Appropriate use

VEGAPULS 63 is a sensor for continuous level measurement.

2.3 Warning about misuse

Inappropriate or incorrect use of the instrument can give rise to application-specific hazards, e.g. vessel overfill or damage to system components through incorrect mounting or adjustment.

2.4 General safety instructions

VEGAPULS 63 is a high-tech instrument requiring the strict observance of standard regulations and guidelines. The emitting frequencies of all VEGAPULS sensors are in the C or K-band range (depending on the instrument version). The low emitted powers are far below the internationally permitted limit values, in case of correct use, no health problems are expected. There are no restrictions in using the instrument also outside metallic, closed vessels. The user must take note of the safety instructions in this operating instructions manual, the country-specific installation standards (e.g. the VDE regulations in Germany) as well as all prevailing safety regulations and accident prevention rules.

2.5 CE conformity

VEGAPULS 63 is in CE conformity with EMC (89/336/EWG), R & TTE directive (1999/5/EC), meets the NAMUR recommendation NE 21 and is in CE conformity with NSR (73/23/EWG).

Conformity has been judged acc. to the following standards:

- EMC:
 - Emission EN 61326: 1997 (class B)
 - Susceptibility EN 61326: 1997/A1: 1998

- R & TTE directive: I-ETS 300-440 Expert opinion No. 0043052-02/SEE, Notified Body No. 0499
- NSR: EN 61010-1: 2001

2.6 Compatibility acc. to NAMUR NE 53

VEGAPULS 63 meets NAMUR recommendation NE 53. VEGA instruments are generally upward and downward compatible:

- sensor software for DTM VEGAPULS 63 HART, PA or FF
- DTM VEGAPULS 63 for adjustment software PACTware™
- adjustment module PLICSCOM for sensor software

The parameter adjustment of the basic sensor functions is independent of the software version. The range of functions depends on the respective software version of the individual components.

The software version of VEGAPULS 63 can be determined as follows:

- via PACTware™
- on the type label of the electronics
- via the adjustment module PLICSCOM

On our website www.vega.com you will find all software histories. Make use of this convenience and get registered for update information via e-mail.

2.7 FCC conformity (only for USA/Canada)

VEGAPULS with all antenna versions are FCC approved.

Modifications must be expressly agreed by VEGA, otherwise the operating licence acc. to FCC will expire.

VEGAPULS 63 is in conformity with part 15 of the FCC regulations. Note the respective regulations for operation:

- The instrument must not cause any interfering emissions
- The instrument must be insensitive to interfering emissions, also to such causing unwanted operating conditions.

2.8 Safety information for Ex areas

Please note the Ex-specific safety information for installation and operation in Ex areas. These safety instructions are part of the operating instructions manual and come with the Ex-approved instruments.

2.9 Environmental instructions

Protection of the environment is one of our most important duties. That is why we have introduced an environment management system with the goal of continuously improving company environmental protection. The environment management system is certified acc. to DIN EN ISO 14001.

Please help us fulfil this obligation by observing the environmental instructions in this manual:

- Chapter "*Storage and transport*"
- Chapter "*Disposal*"

3 Product description

3.1 Configuration

Scope of delivery

The scope of delivery encompasses:

- VEGAPULS 63 radar sensor
- Documentation
 - this operating instructions manual
 - Ex-specific safety instructions (with Ex versions) and, if necessary, further certificates

Components

VEGAPULS 63 consists of the following components:

- Process fitting, flange
- Housing with electronics, optionally available with plug connector, optionally available with connection cable
- Housing cover, optionally available with indicating and adjustment module PLICSCOM

The components are available in different versions.

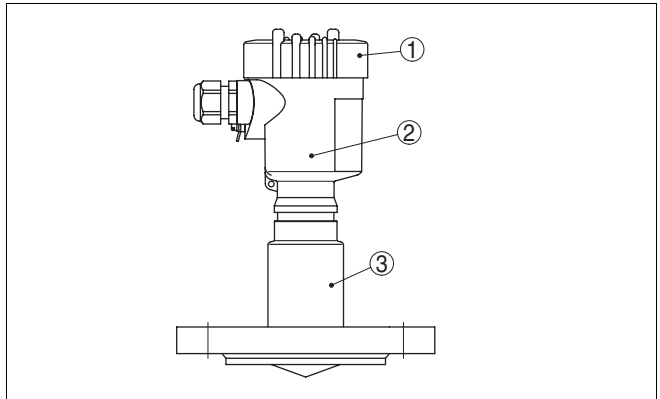

Fig. 1: VEGAPULS 63, flange version with plastic housing

- 1 Housing cover with integrated PLICSCOM (optional)
- 2 Housing with electronics
- 3 Process fitting with encapsulated antenna system

3.2 Principle of operation

Area of application

VEGAPULS 63 is a radar sensor in K-band technology (emitting frequency approx. 26 GHz) for continuous level measurement. It is particularly suitable for small vessels with aggressive liquids under easy process conditions.

For measurement of very corrosive liquids under very difficult process conditions in the chemical, pharmaceutical and food processing industry.

Physical principle

The antenna of the radar sensor emits short radar pulses with a duration of approx. 1 ns. These pulses are reflected by the product and received by the antenna as echoes. The running time of the radar pulses from emission to reception is proportional to the distance and hence to the level. The determined level is converted into an appropriate output signal and outputted as measured value.

Power supply

Two-wire electronics 4 ... 20 mA/HART for power supply and measured value transmission on the same cable.

The power supply range can differ depending on the instrument version. The exact range is stated in the "*Technical data*" in the "*Supplement*".

3.3 Adjustment

VEGAPULS 63 can be adjusted with three different adjustment media:

- the indicating and adjustment module PLICSCOM
- an adjustment software acc. to FDT/DTM standard, e.g. PACTware™ and PC
- a HART handheld

The entered parameters are generally saved in VEGAPULS 63, optionally also in PLICSCOM or in PACTware™.

3.4 Storage and transport

Packaging

Your instrument was protected by packaging during transport. Its capacity to handle normal loads during transport is assured by a test acc. to DIN EN 24180.

The packaging of standard instruments consists of environment-friendly, recyclable cardboard. For special versions PE foam or PE foil is also used. Dispose of the packaging material via specialised recycling companies.

Storage and transport temperature

- Storage and transport temperature see "*Supplement – Technical data – Ambient conditions*"
- Relative humidity 20 ... 85 %

4 Mounting

4.1 General instructions

Installation position

Select an installation position you can easily reach for mounting and connecting as well as later retrofitting of an indicating and adjustment module. The housing can be rotated by 330° without the use of any tools. You can also install the indicating and adjustment module in four different positions (each displaced by 90°).

Moisture

Use the recommended cable (see chapter "*Connecting to power supply*") and tighten the cable entry.

You can give your VEGAPULS 63 additional protection against moisture penetration by leading the connection cable downward in front of the cable entry. Rain and condensation water can thus drain off. This applies mainly to mounting outdoors, in areas where moisture is expected (e.g. by cleaning processes) or on cooled or heated vessels.

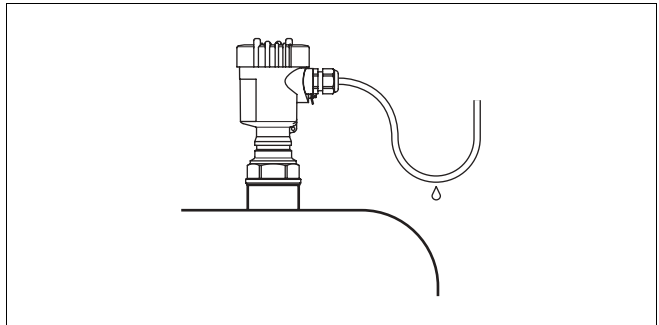

Fig. 2: Measures against moisture penetration

Measuring range

The reference for the measuring range of the sensors is the lower edge of the flange.



Information:

If the product reaches the antenna, buildup can form on it over a period of time and later cause measurement errors.

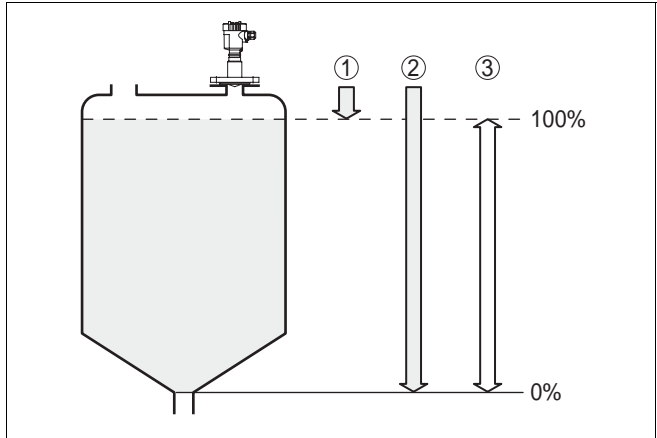

Fig. 3: Measuring range (operating range) and max. measuring distance
 1 full
 2 empty (max. measuring distance)
 3 Measuring range

Pressure

The process fitting must be sealed if there is gauge or low pressure in the vessel. Before use, check if the seal material is resistant against the measured product. The max. permissible pressure is stated in the "Technical data" in the "Supplement" or on the type label of the sensor.

4.2 Mounting information

Installation position

When mounting VEGAPULS 63, keep a distance of at least 200 mm (7.9 in) to the vessel wall. If the sensor is installed in the center of concave or arched vessel tops, multiple echoes can arise. These can, however, be faded out by an appropriate adjustment (see "Setup").

If this distance cannot be maintained, a false echo storage should be carried out during setup. This applies particularly if buildup on the vessel wall is expected. In this case, we recommend repeating the false echo storage later on with existing buildup.

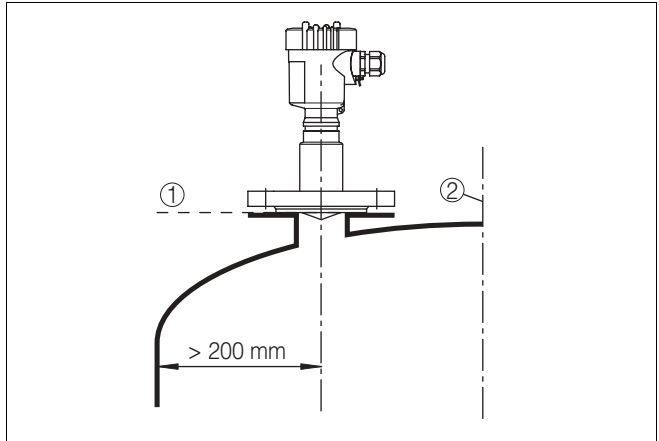

Fig. 4: Mounting on rounded vessel tops

- 1 Reference plane
- 2 Vessel center or symmetry axis

In vessels with conical bottom it can be advantageous to mount the sensor in the center of the vessel, as measurement is then possible down to the lowest point of the vessel bottom.

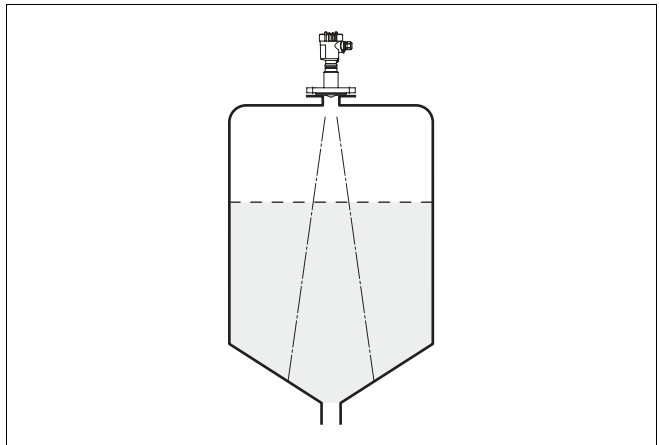

Fig. 5: Vessel with conical bottom

Inflowing material

Do not mount the instruments in or above the filling stream. Make sure that you detect the product surface and not the inflowing product.

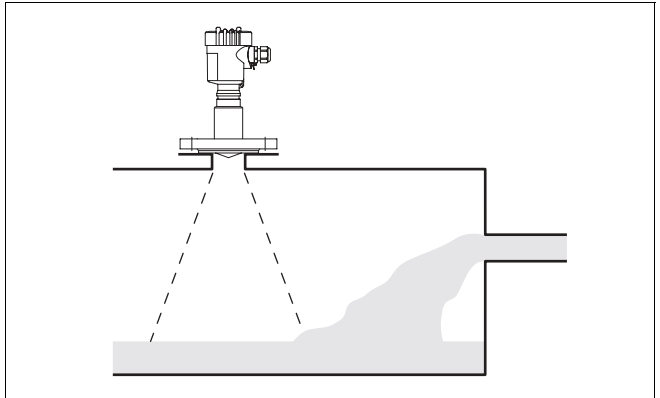

Fig. 6: Inflowing liquid

Socket

If the reflective properties of the medium are good, you can mount VEGAPULS 63 on socket pieces. You will find recommended values of the socket heights in the following illustration. The socket end should be smooth and burr-free, if possible also rounded. Carry out a false echo storage.

The optimum installation location of the sensor, also in respect to the cleanability, is on a block flange or with hygienic fittings, e.g. Neumo Biocontrol.

In case of deviating socket dimensions, a false echo storage should be carried out during setup.

The flange screws of VEGAPULS 63 must always be tightened with a torque of approx. 60 Nm (44 lbf ft) so that the PTFE washer seals reliably.

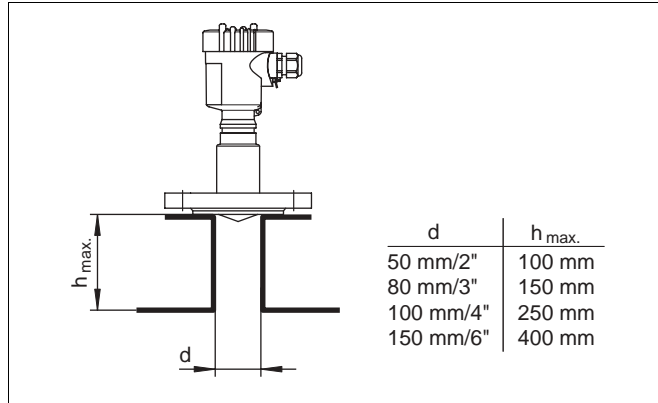

Fig. 7: Deviating socket dimensions

Sensor orientation

In liquids, direct the sensor as close as vertical to the product surface to achieve an optimum measurement.

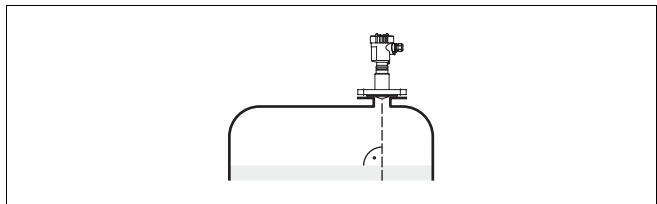

Fig. 8: Orientation in liquids

Vessel installations

The radar sensor should be installed at a location where no installations cross the radar signals.

Vessel installations such as, for example, ladders, limit switches, heating spirals, struts, etc. can cause false echoes superimposed on the useful echo. Make sure when planning your measuring location that the radar signals have "free access" to the measured product.

If there are existing vessel installations, a false echo storage should be carried out during setup.

If large vessel installations such as struts or supports cause false echoes, these can be attenuated through supplementary measures. Small, inclined sheet metal baffles above the installations scatter the radar signals and avoid a direct false echo reflection.

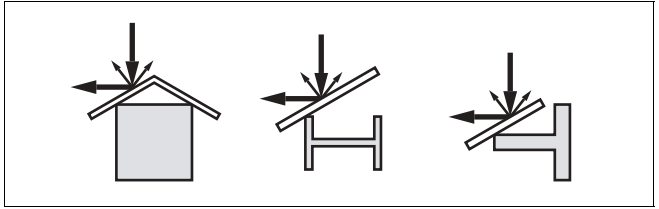

Fig. 9: Cover smooth profiles with deflectors

Agitators

If there are agitators in the vessel, a false echo storage should be carried out with the agitators in motion. This ensures that the interfering reflections from the agitators are saved with the blades in different positions.

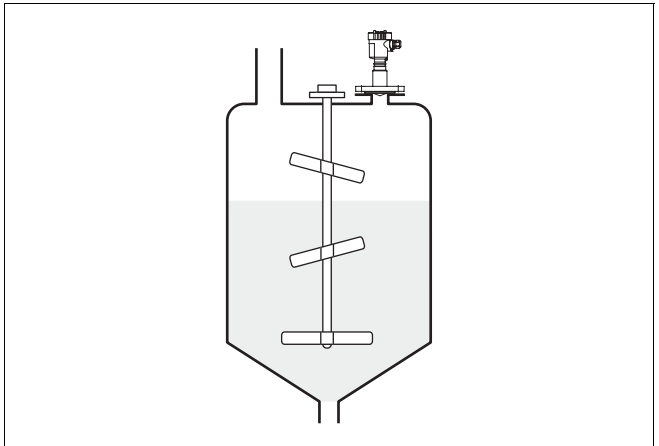

Fig. 10: Agitators

Foam generation

Through the action of filling, stirring and other processes in the vessel, dense foams which considerably damp the emitted signals may form on the product surface.

If foams can cause measurement errors, biggest possible radar antennas and low frequency radar sensors, e.g. VEGAPULS 65, 66 (C-band) should be used.

VEGAFLEX sensors with guided microwaves are not influenced by foam generation and are particularly suitable for such applications.

Measurement in the standpipe (surge or bypass tube)

By the use of a standpipe, influences of vessel installations and turbulence can be excluded. Under these requirements, the measurement of products with low dielectric values (from DK value 1.6) is possible.

Surge or bypass tubes must extend all the way down to the requested min. level, as measurement is only possible within the tube.

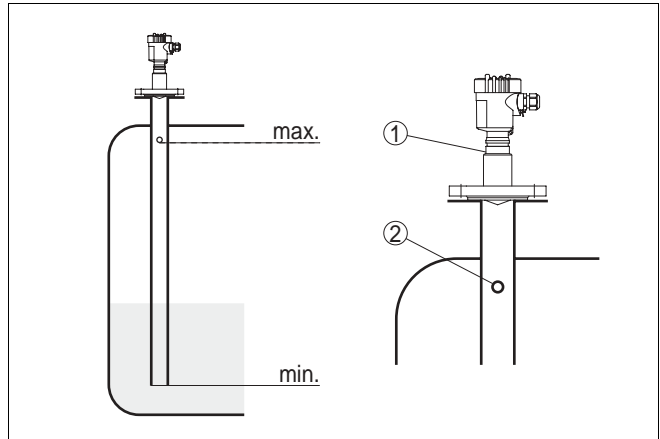

Fig. 11: Pipe antenna systems in a tank
 1 Marking of the polarisation direction
 2 Vent hole, max. diameter 5 mm (0.2 in)

If possible, the antenna diameter of the sensor should correspond to the inner diameter of the tube. With VEGAPULS 63 these are approx. 50 mm (2 in). The sensor can be used from tube diameters of 50 ... 80 mm (2 ... 3.2 in).

Take note of the necessary upper vent hole in the surge pipe which must be displaced by 90° to the polarisation direction on the sensor (see illustration: "Pipe antenna systems in a tank").

As an alternative to the surge pipe in the vessel, a pipe system outside of the vessel is possible as bypass tube. For setup, select the function "Bypass tube".

Direct the sensor in such a way that the polarisation marking on the process fitting is displaced by 90° to the tube holes or the tube connection openings (see illustration: "VEGAPULS in a bypass tube").

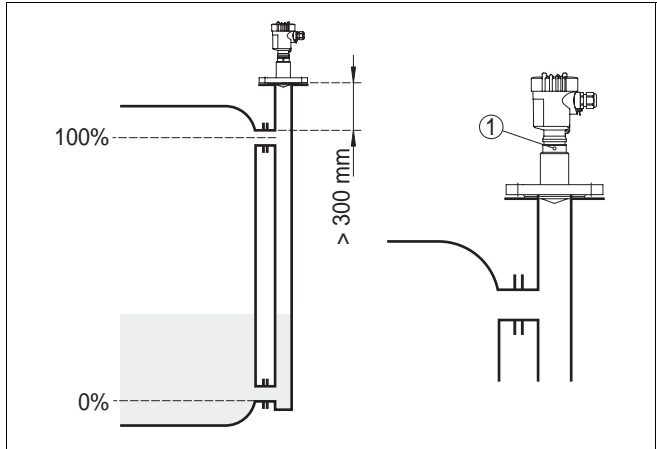

Fig. 12: VEGAPULS in a bypass tube
1 Marking of the polarisation direction

When mounting the sensor on a bypass tube, VEGAPULS 63 should be mounted at a distance of approx. 300 mm (12 in) or more from the upper pipe connection. In case the tube is very rough inside, an inserted tube (tube in tube) or a radar sensor with pipe antenna should be used.

5 Connecting to power supply

5.1 Preparing the connection

Note safety instructions

Always observe the following safety instructions:

- Connect only in the complete absence of line voltage
- If overvoltages are expected, overvoltage arresters should be installed.



Tip:

We recommend VEGA overvoltage arresters ÜS-F-LB-I and ÜSB 62-36G.X.

Take note of safety instructions for Ex applications



In hazardous areas you should take note of the appropriate regulations, conformity and type approval certificates of the sensors and power supply units.

Select power supply

Power supply and current signal are transmitted via the same two-wire connection cable. The power supply range can differ depending on the instrument version. The exact range is stated in the "*Technical data*" in the "*Supplement*".

Provide a reliable separation between the supply circuit and the mains circuits acc. to DIN VDE 0106 part 101. The VEGA power supply units VEGATRENN 149AEx, VEGASTAB 690, VEGADIS 371 as well as all VEGAMETs meet this requirement.

Bear in mind the following factors regarding supply voltage:

- the reduction of the output voltage of the power supply unit under nominal load (with a sensor current of 20.5 mA or 22 mA in case of fault signal)
- the influence of additional instruments in the circuit (see load values in "*Technical data*")

Select connection cable

VEGAPULS 63 is connected with standard two-wire cable without screen. An outer cable diameter of 5 ... 9 mm ensures the seal effect of the cable entry. If electromagnetic interference is expected, we recommend the use of screened cable.

Cable screening and grounding

Connect the cable screen on both ends to ground potential. In the sensor, the screen must be connected directly to the internal ground terminal. The ground terminal outside on the housing must be connected to the potential equalisation (low impedance).

If potential equalisation currents are expected, the connection on the evaluation side must be made via a ceramic capacitor (e.g. 1 nF, 1500 V). The low frequency potential equalisation currents are thus suppressed, but the protective effect against high frequency interference signals remains.

Select connection cable for Ex applications



Take note of the corresponding installation regulations for Ex applications. In particular, make sure that no potential equalisation currents flow over the cable screen. In case of grounding on both sides this can be achieved by the use of a capacitor or a separate potential equalisation.

5.2 Connection procedure

Proceed as follows:

- 1 Unscrew the housing cover
 - 2 If an indicating and adjustment module is installed, remove it by turning it slightly to the left.
 - 3 Loosen compression nut of the cable entry
 - 4 Remove approx. 10 cm (4 in) of the cable mantle, strip approx. 1 cm (0.4 in) insulation from the ends of the individual wires
 - 5 Insert the cable into the sensor through the cable entry
 - 6 Lift the opening levers of the terminals with a screwdriver (see following illustration)
 - 7 Insert the wire ends into the open terminals according to the wiring plan
 - 8 Press down the opening levers of the terminals, you will hear the terminal spring closing
 - 9 Check the hold of the wires in the terminals by lightly pulling on them
 - 10 Connect the screen to the internal ground terminal and the external ground terminal to potential equalisation
 - 11 Tighten the compression nut of the cable entry, the seal ring must completely encircle the cable
 - 12 Screw the housing cover back on
- The electrical connection is finished.

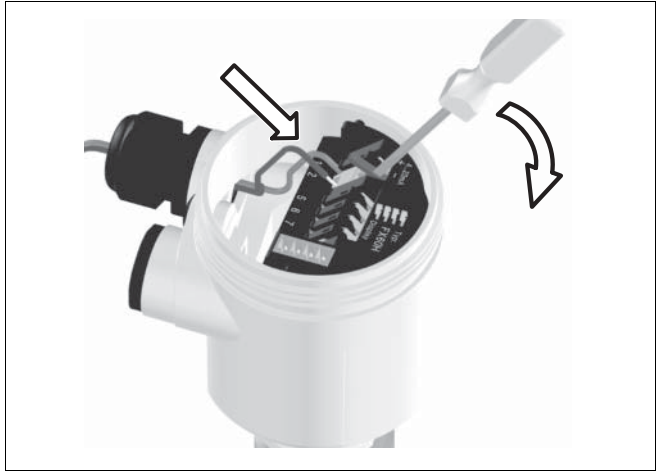

Fig. 13: Connection steps 6 and 7

5.3 Wiring plans, single chamber housing



The following illustrations apply to the non-Ex as well as to the Ex ia version.

Housing overview

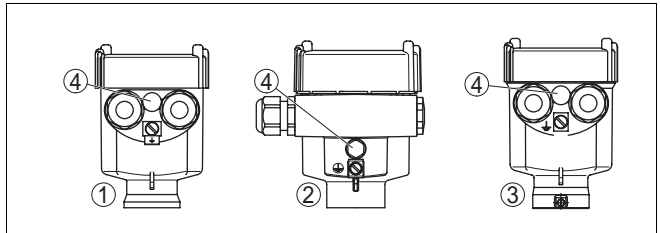

Fig. 14: Material versions, single chamber housing

- 1 Plastic
- 2 Aluminium
- 3 Stainless steel
- 4 Filter element for pressure compensation or blind stopper with version IP 66/
IP 68, 1 bar

Electronics and connection compartment

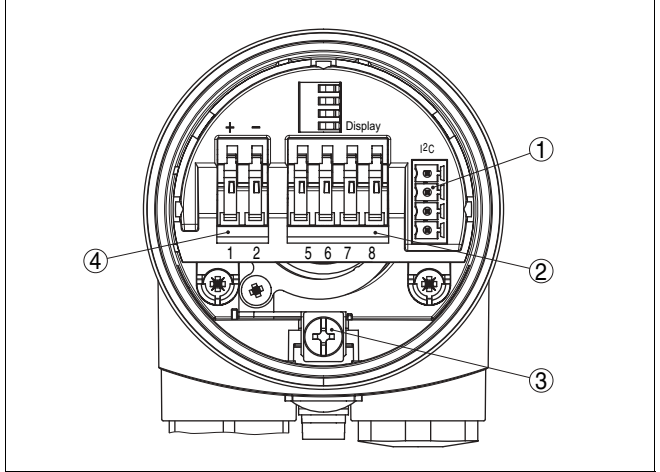

Fig. 15: Electronics and connection compartment, single chamber housing
 1 Plug connector for VEGACONNECT (I²C interface)
 2 Spring-loaded terminals for connection of the external indication VEGADIS 61
 3 Ground terminal for connection of the cable screen
 4 Spring-loaded terminals for power supply

Wiring plan

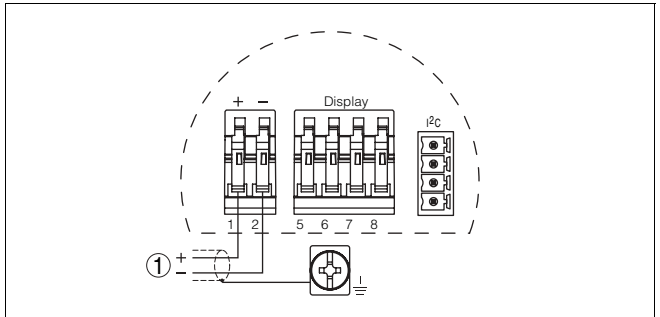

Fig. 16: Wiring plan, single chamber housing
 1 Power supply/Signal output

5.4 Wiring plans, double chamber housing



The following illustrations apply to the non-Ex as well as to the Ex ia version. The Exd version is described in the next subchapter.

Housing overview

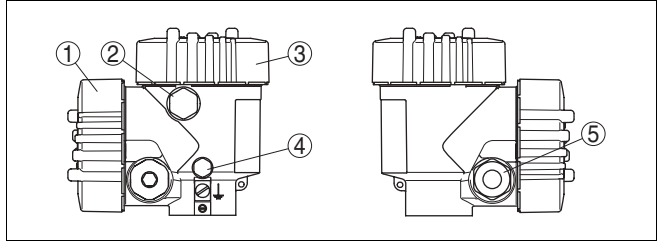

Fig. 17: Double chamber housing

- 1 Housing cover, connection compartment
- 2 Blind stopper or plug M12x1 for VEGADIS 61 (option)
- 3 Housing cover, electronics compartment
- 4 Filter element for pressure compensation or blind stopper with version IP 66/ IP 68, 1 bar¹⁾
- 5 Cable entry or plug

Electronics compartment

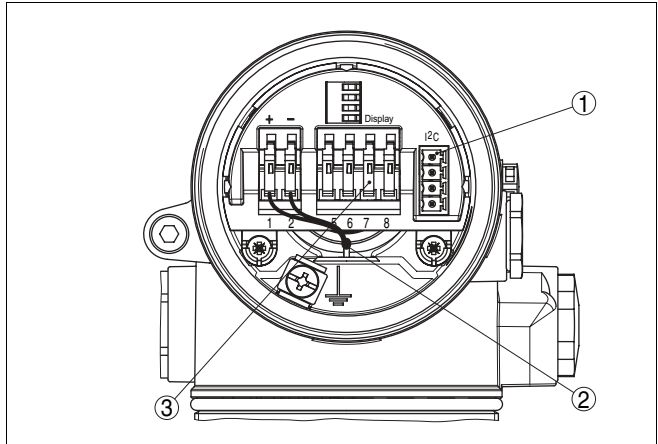

Fig. 18: Electronics compartment, double chamber housing

- 1 Plug connector for VEGACONNECT (I²C interface)
- 2 Internal connection cable to the connection compartment
- 3 Terminals for VEGADIS 61

¹⁾ Version IP 66/IP 68, 1 bar not with four-wire instruments

Connection compartment

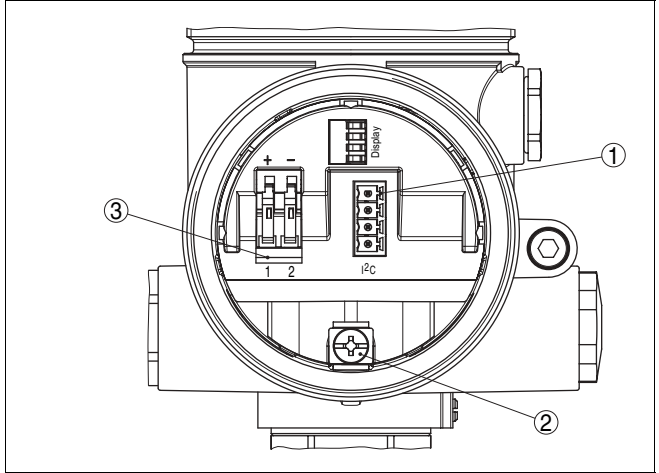

Fig. 19: Connection compartment, double chamber housing

- 1 Plug connector for VEGACONNECT (I²C interface)
- 2 Ground terminal for connection of the cable screen
- 3 Spring-loaded terminals for power supply

Wiring plan

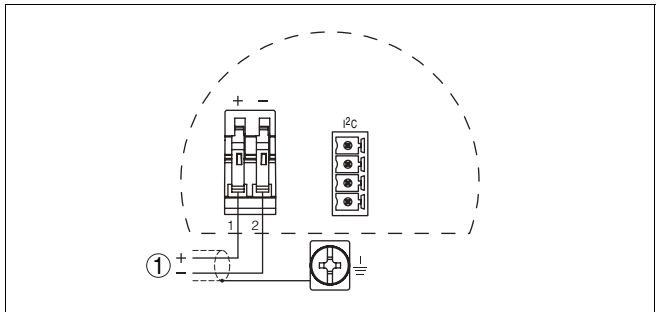

Fig. 20: Wiring plan, double chamber housing

- 1 Power supply/Signal output

5.5 Wiring plans, double chamber housing Exd

Housing overview

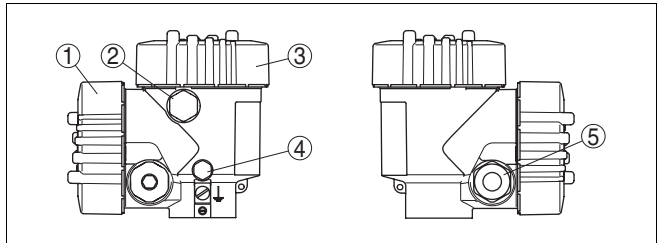

Fig. 21: Double chamber housing

- 1 Housing cover, connection compartment
- 2 Blind stopper or plug M12x1 for VEGADIS 61 (option)
- 3 Housing cover, electronics compartment
- 4 Filter element for pressure compensation or blind stopper with version IP 66/ IP 68, 1 bar²⁾
- 5 Cable entry or plug

Electronics compartment

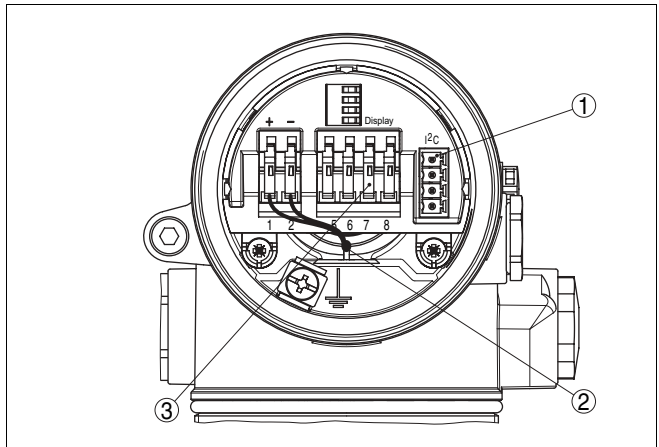

Fig. 22: Electronics compartment, double chamber housing

- 1 Plug connector for VEGACONNECT (I²C interface)
- 2 Internal connection cable to the connection compartment
- 3 Terminals for VEGADIS 61

²⁾ Version IP 66/IP 68, 1 bar not with four-wire instruments

Connection compartment

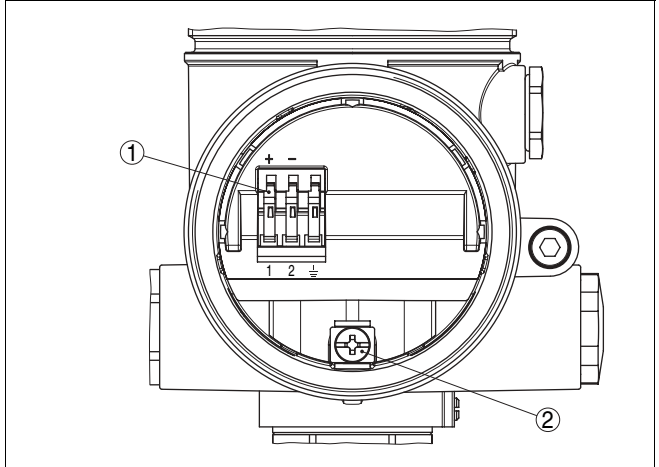

Fig. 23: Connection compartment, double chamber housing Exd

- 1 Spring-loaded terminals for power supply and cable screen
- 2 Ground terminal for connection of the cable screen

Wiring plan

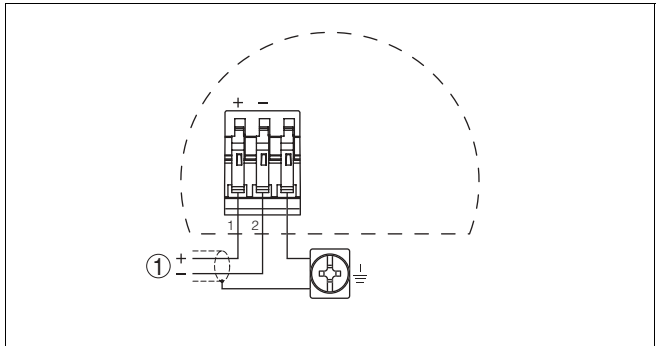

Fig. 24: Wiring plan, double chamber housing Exd

- 1 Power supply/Signal output

5.6 Wiring plans, version IP 66/IP 68, 1 bar

Wire assignment, connection cable

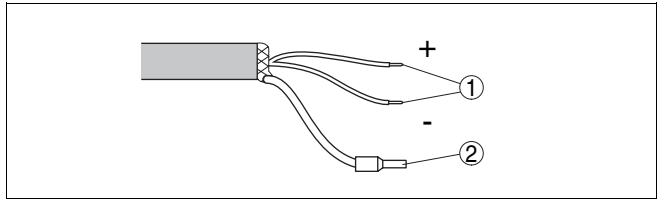

Fig. 25: Wire assignment, connection cable

- 1 br (+) and bl (-) for power supply or to the processing system
2 Screen

5.7 Switch on phase

Switch on phase

After VEGAPULS 63 is connected to power supply, the instrument carries out a self-test for approx. 30 seconds. The following steps are carried out:

- Internal check of the electronics
- Indication of the instrument type, the firmware version as well as the sensor TAGs (sensor name)
- Output signal jumps briefly (approx. 10 seconds) to the set error current

Then the actual measured value is displayed and the corresponding current is transmitted to the cable.³⁾

³⁾ The values correspond to the actual level as well as to the settings already carried out, e.g. default setting.

6 Setup with the indicating and adjustment module PLICSCOM

6.1 Short description

Function/Configuration

The indicating and adjustment module PLICSCOM is used for measured value display, adjustment and diagnosis. It can be mounted in the following housing versions and instruments:

- All sensors of the plics[®] instrument family, in the single as well as in the double chamber housing (optionally in the electronics or connection compartment)
- External indicating and adjustment unit VEGADIS 61.



Note:

You will find detailed information on the adjustment in the operating instructions manual of the indicating and adjustment module PLICSCOM.

6.2 Installing the indicating and adjustment module PLICSCOM

Insert/remove PLICSCOM

PLICSCOM can be inserted or removed at any time. It is not necessary to interrupt the power supply.

Proceed as follows:

- 1 Unscrew the housing cover
- 2 Place PLICSCOM in the desired position on the electronics (you can choose any one of four different positions - each displaced by 90°)
- 3 Press PLICSCOM lightly onto the electronics and turn it to the right until it snaps in.
- 4 Screw housing cover with inspection window tightly back on

Removal is carried out in reverse order.

PLICSCOM is powered by the sensor, an additional connection is not necessary.



Fig. 26: Installation of PLICSCOM



Note:

If you intend to retrofit VEGAPULS 63 with a PLICSCOM for continuous measured value indication, a higher cover with an inspection glass is required.

6.3 Adjustment system

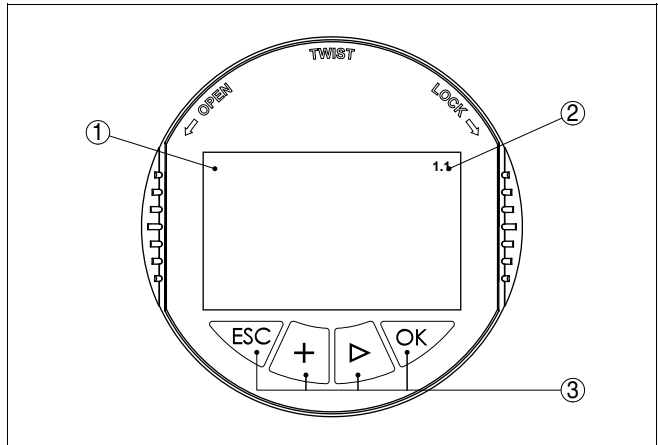

Fig. 27: Indicating and adjustment elements

- 1 LC display
- 2 Indication of the menu item number
- 3 Adjustment keys

Key functions

- **[OK]** key:
 - move to the menu overview
 - confirm selected menu
 - edit parameter
 - save value
- **[->]** key to select:
 - menu change
 - list entry
 - editing position
- **[+]** key:
 - modify value of a parameter
- **[ESC]** key:
 - interrupt input
 - jump to the next higher menu

Adjustment system

The sensor is adjusted via the four keys of the indicating and adjustment module. The LC display indicates the individual menu items. The functions of the individual keys are shown in the above illustration. Approx. 10 minutes after the last pressing of a key, an automatic reset to measured value indication is triggered. Any values not confirmed with **[OK]** will not be saved.

6.4 Setup procedure

Address setting HART-Multi-drop

In HART-Multidrop mode (several sensors on one input) the address must be set before continuing with the parameter adjustment. You will find a detailed description in the operating instructions manual of PLICSCOM or in the online help of PACTware™ or DTM.

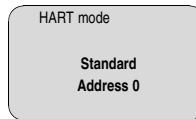

Parameter adjustment

Because VEGAPULS 63 is a distance measuring instrument, the distance from the sensor to the product surface is measured. In order to have the actual product level displayed, an allocation of the measured distance to the height percentage must be carried out. To make this adjustment, the full and empty distances in the vessel are entered. If these values are known, it is also possible to carry out the adjustment with other distances, e.g. 10 % and 90 %. Starting point of these distance values is always the seal surface of the thread or flange. The actual level is then calculated on the basis of these entered values. At the same time, the operating range of the sensor is limited from maximum range to the requested range.

The real product level during this adjustment is not important, because the min./max. adjustment is always carried out without changing the product level. These settings can be made ahead of time without the instrument having to be installed.

In the main menu item "*Basic adjustment*", the individual submenu items should be selected one after the other and provided with the correct parameter values.

Start your parameter adjustment with the following menu items of the basic adjustment:

Carrying out min. adjustment

Proceed as follows:

- 1 Move from the measured value display to the main menu by pushing **[OK]**.

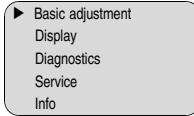

- 2 Select the menu item *Basic adjustment* with **[→]** and confirm with **[OK]**. Now the menu item "Min. adjustment" is displayed.

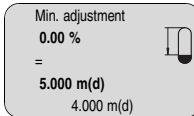

- 3 Prepare the % value for editing with **[OK]** and set the cursor to the requested position with **[→]**. Set the requested percentage value with **[+]** and save with **[OK]**. The cursor jumps now to the distance value.
- 4 Enter the appropriate distance value in m (corresponding to the percentage value) for the empty vessel (e.g. distance from the sensor to the vessel bottom).
- 5 Save the settings with **[OK]** and move to "Max. adjustment" with **[→]**.

Carrying out max. adjustment Proceed as follows:

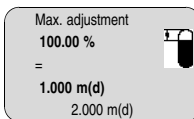

- 1 Prepare the % value for editing with **[OK]** and set the cursor to the requested position with **[→]**. Set the requested percentage value with **[+]** and save with **[OK]**. The cursor jumps now to the distance value.
- 2 Enter the appropriate distance value in m (corresponding to the percentage value) for the full vessel. Keep in mind that the max. level must lie below the dead band.
- 3 Save the settings with **[OK]** and move to "Medium selection" with **[→]**.

Medium selection

Each product has different reflective properties. In addition, there are various interfering factors which have to be taken into account: agitated product surfaces and foam generation (with liquids); dust generation, material cones and echoes from the

vessel wall (with solids). To adapt the sensor to these different conditions, you should first select in this menu item "*Liquid*" or "*Solid*".

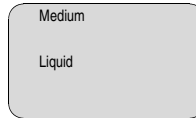

According to the conductivity and the dielectric value of liquids, the reflection properties can differ considerably. Therefore additional options such as "*Solvent*", "*Chem. mixture*" and "*Water based*" are offered below the menu item Liquid.

With solids, you can also choose between "*Powder/Dust*", "*Granular/Pellets*" or "*Ballast/Pebbles*".

Through this additional selection, the sensor is adapted perfectly to the product and measurement reliability, particularly in products with bad reflective properties, is considerably increased.

Enter the requested parameter via the appropriate keys, save your settings and jump to the next menu item with the **[→]** key.

Vessel shape

Apart from the medium also the vessel form can influence the measurement. To adapt the sensor to these conditions, this menu item offers (depending on either liquid or solid is selected) different options. With "*Solid*" these are "*Silo*" or "*Bunker*", with "*Liquid*", "*Storage tank*", "*Stilling tube*", "*Open vessel*" or "*Stirred vessel*".

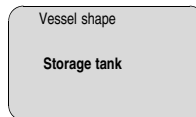

Enter the requested parameter via the appropriate keys, save your settings and jump to the next menu item with the **[→]** key.

Damping

To suppress fluctuation in the measured value display, caused e.g. by a turbulent product surface, an integration time can be set. This time can be between 0 and 999 seconds. Please note that the reaction time of the entire measurement will be longer and the sensor will react to quick changes of the measured value with a corresponding delay. In general, a time of a few seconds is sufficient to smooth the measured value display.

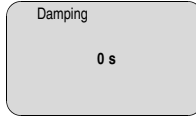

Enter the requested parameter via the appropriate keys, save your settings and jump to the next menu item with the **[→]** key.

Linearization curve

A linearization is necessary for all vessels in which the vessel volume does not increase linearly with the level – e.g. in a cylindrical or spherical tank – and the indication or output of the volume is requested. Corresponding linearization curves are preprogrammed for these vessels. They represent the correlation between the level percentage and vessel volume. By activating the appropriate curve, the volume percentage of the vessel is displayed correctly. If the volume should not be displayed in percent but e.g. in l or kg, a scaling can be also set in the menu item "*Display*".

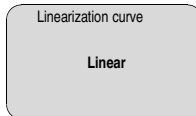

Enter the requested parameter via the appropriate keys, save your settings and jump to the next menu item with the **[→]** key.

Sensor-TAG

In this menu item you can enter an unambiguous designation for the sensor, e.g. the measurement loop name or the tank or product designation. In digital systems and in the documentation of larger plants, a singular designation should be entered for exact identification of individual measuring sites.

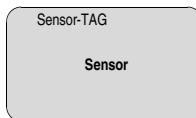

With this menu item, the Basic adjustment is finished and you can now jump to the main menu with the **[ESC]** key.

False echo storage

High sockets or vessel installations, such as e.g. struts or agitators as well as buildup and weld joints on the vessel walls cause interfering reflections which can impair the measurement. A false echo storage detects and marks these false echoes, so that they are no longer taken into account for the

level measurement. A false echo memory should be created with empty vessel so that all potential interfering reflections will be detected.

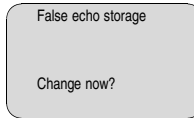

Proceed as follows:

- 1 Move from the measured value display to the main menu by pushing **[OK]**.
- 2 Select the menu item "Service" with **[->]** and confirm with **[OK]**. Now the menu item "False echo storage" is displayed.
- 3 Confirm "False echo storage - Change now" with **[OK]** and select in the below menu "Create new". Enter the actual distance from the sensor to the product surface. All false echoes in this area are detected by the sensor and saved after confirming with **[OK]**.



Note:

Check the distance to the product surface, because if an incorrect (too large) value is entered, the existing level will be saved as false echo. The filling level would then no longer be detectable in this area.

Optional settings

Additional adjustment and diagnosis options such as e.g. scaling, simulation or trend curve presentation are shown in the following menu schematic. You will find a detailed description of these menu items in the operating instructions manual of the indicating and adjustment module.

6.5 Menu schematic

Basic adjustment

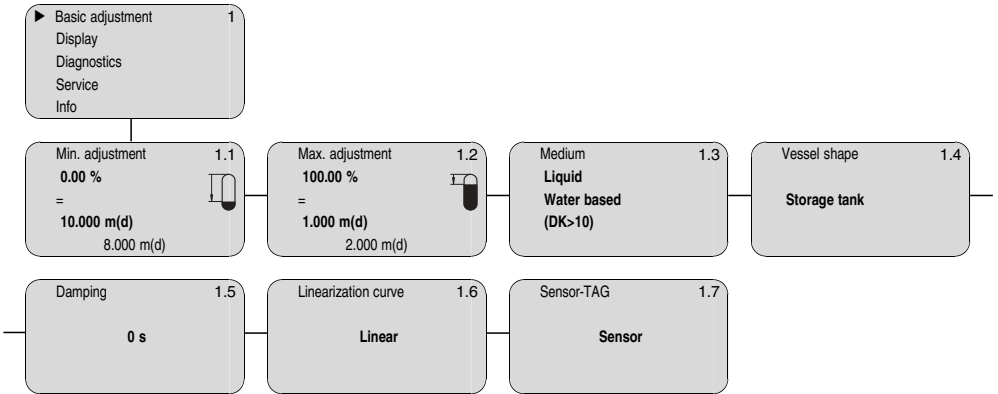

Display

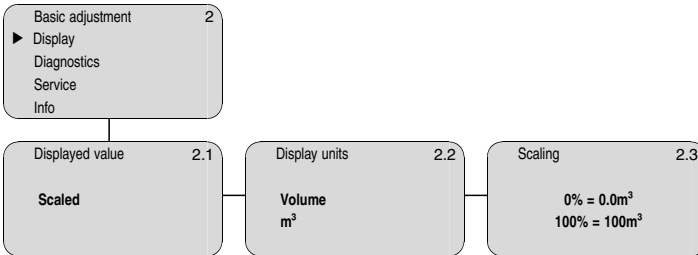

Diagnostics

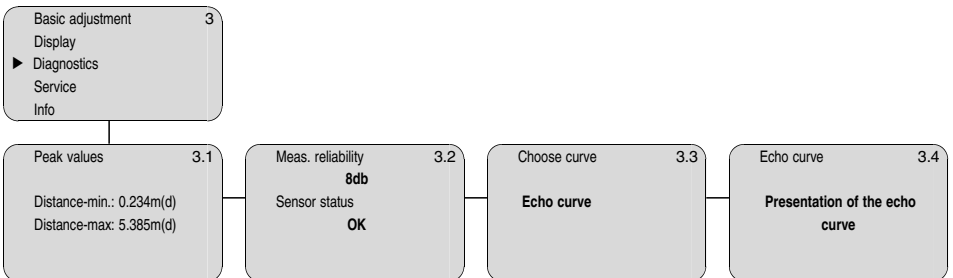

Service

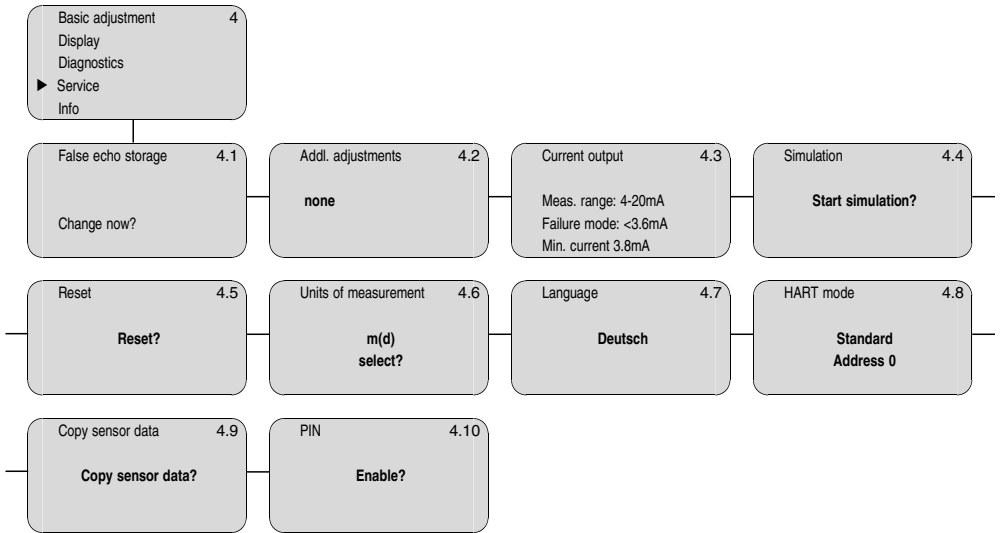

Info

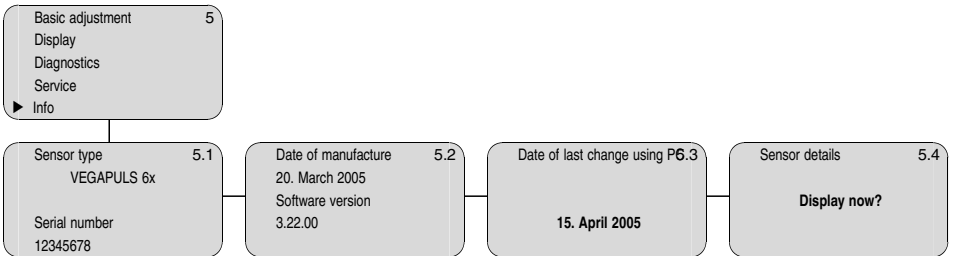

7 Setup with PACTware™

7.1 Connecting the PC

Connecting the PC directly to the sensor

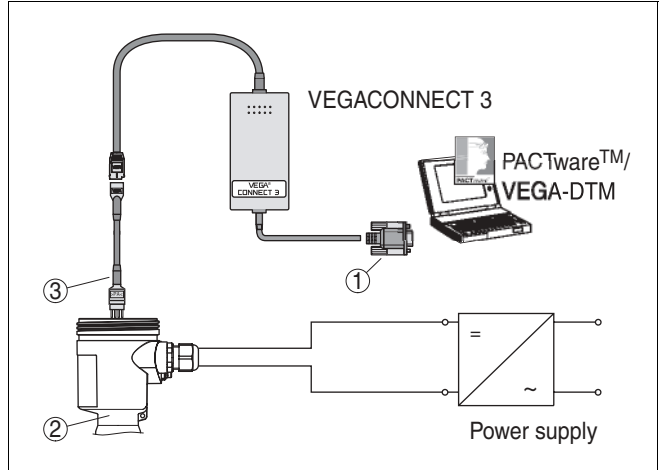

Fig. 28: PC connected directly to the sensor

- 1 RS232 connection
- 2 VEGAPULS 63
- 3 I²C adapter cable for VEGACONNECT 3

Necessary components:

- VEGAPULS 63
- PC with PACTware™ and suitable VEGA-DTM
- VEGACONNECT 3 with I²C adapter cable (article no. 2.27323)
- power supply unit

Connecting the PC to the signal cable

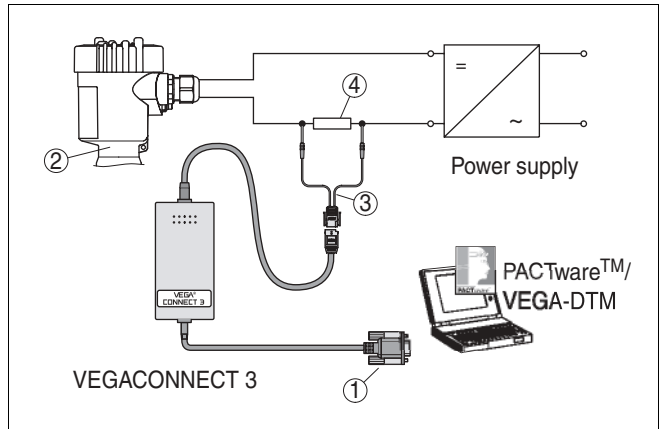

Fig. 29: Connecting the PC to the signal cable

- 1 RS232 connection
- 2 VEGAPULS 63
- 3 HART adapter cable for VEGACONNECT 3
- 4 HART resistance 250 Ohm

Necessary components:

- VEGAPULS 63
- PC with PACTware™ and suitable VEGA-DTM
- VEGACONNECT 3 with HART adapter cable (art. no. 2.25397)
- HART resistance approx. 250 Ohm
- power supply unit



Note:

With power supply units with integrated HART resistance (internal resistance approx. 250 Ohm), an additional external resistance is not necessary (e.g. VEGATRENN 149A, VEGA-DIS 371, VEGAMET 381). In such cases, VEGACONNECT 3 can be connected parallel to the 4 ... 20 mA cable.

7.2 Parameter adjustment with PACTware™

Further setup steps are described in the operating instructions manual *DTM Collection/PACTware™* attached to each CD and which can also be downloaded from our homepage. A detailed description is available in the online help of PACTware™ and the VEGA-DTMs.



Note:

Keep in mind that for setup of VEGAPULS 63, DTM-Collection 06/2003 or a newer version must be used.

All currently available VEGA-DTMs are provided in the DTM Collection on CD and can be obtained from the responsible VEGA agency for a token fee. This CD includes also the up-to-date PACTware™ version. The basic version of this DTM Collection incl. PACTware™ is also available as a free-of-charge download from the Internet.

8 Maintenance and fault rectification

8.1 Maintenance

When used as directed in normal operation, VEGAPULS 63 is completely maintenance-free.

8.2 Fault rectification

Causes of malfunction

VEGAPULS 63 offers maximum reliability. Nevertheless faults can occur during operation. These may be caused by the following, e.g.:

- Sensor
- Process
- Power supply
- Signal processing.

Fault rectification

The first measures to be taken are to check the output signal as well as evaluate failure messages via the indicating and adjustment module PLICSCOM. The procedure is described in the following. Further comprehensive diagnostics options offer a laptop with the software PACTware™ and the suitable DTM. In many cases, the reasons can be determined in this way and faults can be rectified.

24 hour service hotline

Should these measures not be successful, please call in urgent cases the VEGA service hotline under the phone number **+49 1805 858550**.

The hotline is available to you 7 days a week round-the-clock. Since we offer this service world-wide, the support is only available in the English language. The service is free of charge, only the standard telephone costs will be charged.

Checking the 4 ... 20 mA signal

Connect a hand-held multimeter with a suitable measuring range acc. to the wiring plan.

? 4 ... 20 mA signal not stable

- level fluctuations
- set integration time via PLICSCOM or PACTware™

? 4 ... 20 mA signal missing

- incorrect connection to power supply
- Check connection acc. to chapter "*Connection proce-*

ture" and correct, if necessary, acc. to chapter "*Wiring plans*"

- no power supply
- check cables for line break, repair, if necessary
- supply voltage too low or load resistance too high
- check and adapt, if necessary

- ? Current signal greater than 22 mA or less than 3.6 mA
- Electronics module defective
 - exchange instrument or return it for repair



In Ex applications, the regulations for the wiring of intrinsically safe circuits must be observed.

Fault messages via PLICSCOM

- ? E013
- no measured value available
 - sensor in boot phase
 - sensor does not find an echo, e.g. because of faulty installation or incorrect parameter adjustment
- ? E017
- adjustment span too small
 - Carry out a fresh adjustment and increase the distance between min. and max. adjustment
- ? E036
- no operable sensor software
 - carry out a software update or return instrument for repair
- ? E041
- hardware error, electronics defective
 - exchange instrument or return it for repair

8.3 Exchanging the electronics

If the electronics module is defective, it can be replaced by the user.



In Ex applications, only one instrument and one oscillator with appropriate Ex approval must be used.

If there is no electronics module available on site, it can be ordered from the responsible VEGA agency.

Sensor serial number

The order data of the sensor must be loaded in the new oscillator. These are the options:

- at the factory by VEGA personnel
- or on site by the user.

In both cases, the sensor serial number is necessary. The serial numbers are stated on the type label of the instrument or on the delivery note.



Information:

When loading on site, the order data must be downloaded from the Internet (see Operating Instructions manual of the oscillator).

Assignment

The oscillators are adapted to the appropriate sensor and differ in the signal output as well as in the power supply. The suitable oscillator is listed in the below overview.

4 ... 20 mA/HART

Electronics module PS-E.60KH. is suitable for K-band VEGAPULS 61, 62, 63 – 4 ... 20mA/HART:

- PS-E.60KH**X** (X = without approvals)
- PS-E.60KH**A** (A = approvals CA, DA, EA acc. to VEGA product list)
- PS-E.60KH**C** (C = approvals XM, CX, CM, CK, CI, DX, DM, DK, DI, EX, GX acc. to VEGA product list)

8.4 Instrument repair

If it is necessary to repair VEGAPULS 63 please proceed as follows:

You can download a return form (23 KB) from our homepage www.vega.com under: "*Services – Downloads – Forms and Certificates – Repair form*".

By doing this you help us carry out the repair quickly and without having to call back for needed information.

- Print and fill out one form per instrument
- Clean the instrument and pack it damage-proof
- Attach the completed form and possibly also a safety data sheet to the instrument.
- Send the instrument to the respective address of your agency. In Germany to the VEGA headquarters in Schiltach.

9 Dismounting

9.1 Dismounting procedure

**Warning:**

Before dismounting, be aware of dangerous process conditions such as e.g. pressure in the vessel, high temperatures, corrosive or toxic products etc.

Take note of chapters "*Mounting*" and "*Connecting to power supply*" and carry out the listed steps in reverse order.

9.2 Disposal

VEGAPULS 63 consists of materials which can be recycled by specialised recycling companies. We have purposely designed the electronic modules to be easily separable. Mark the instrument as scrap and dispose of it according to government regulations (electronic scrap ordinance, ...).

Materials: see "*Technical data*"

If you cannot dispose of the instrument properly, please contact us about disposal methods or return.

10 Supplement

10.1 Technical data

General data

Materials, wetted parts

- Process fitting 316L (1.4435)
- Antenna PTFE (TFM 1600), PFA plated

Materials, non-wetted parts

- Housing plastic PBT (Polyester), Alu-die casting powder-coated, stainless steel 316L
- Seal ring between housing and housing cover NBR (stainless steel housing), silicone (Alu/plastic housing)
- Inspection window in housing cover for PLICSCOM Polycarbonate (UL746-C listed)
- Ground terminal 316Ti/316L (1.4571/1.4435)

Weight

- Tri-Clamp, bolting 3.5 ... 6.0 kg (7.7 ... 13.2 lbs), depending on size and housing material
- flanges 4.2 ... 15.4 kg (9.3 ... 34 lbs), depending on flange size and housing material

Output variable

Output signal	4 ... 20 mA/HART
Resolution	1.6 μ A
Fault signal	current output unchanged; 20.5 mA; 22 mA; <3.6 mA (adjustable)
Current limitation	22 mA
Load	see load diagram in Power supply
Integration time (63 % of the input variable)	0 ... 999 s, adjustable
Rise time	150 ms (ti: 0 s, 0 ... 100 %)
Fulfilled NAMUR recommendation	NE 43

Input variable

Parameter	distance between process fitting and product surface
min. distance from flange	50 mm (2.0 in)
meas. range depending on process fitting	
– Tri-Clamp 2", 3", 4"	up to 10 m (33 ft)
– bolting DN 50, DN 80	up to 10 m (33 ft)

– flange DN 50, ANSI 2"	up to 10 m (33 ft)
– flange DN 80 ... DN 150, AN-SI 3" ... 6"	up to 20 m (66 ft)

Accuracy (similar to DIN EN 60770-1)

Reference conditions acc. to DIN EN 61298-1

– Temperature	18 ... +30°C (64 ... +86°F)
– Relative humidity	45 ... 75 %
– Atmospheric pressure	860 ... 1060 mbar (86 ... 106 kPa/ 12.5 ... 15.4 psi)

Characteristic curve deviation and measurement characteristics⁴⁾

Average temperature coefficient of the zero signal (temperature error)	0.06 %/10 K
Resolution, general	max. 1 mm
Frequency	K-band (26 GHz technology)
Interval	approx. 1 s
Beam angle	
– Tri-Clamp 2"	18°
– Tri-Clamp 3", 4"	10°
– Bolting DN 50	18°
– bolting DN 80	10°
– flange DN 50, ANSI 2"	18°
– flange DN 80 ... DN 150, AN-SI 3" ... 6"	10°
Adjustment time ⁵⁾	>1 s (dependent on the parameter adjustment)
Received average emitted power reaching an object directly in front of the antenna	
– distance 1 m	108 nW per cm ² (108x10 ⁻⁹ W/cm ²)
– distance 5 m	4.3 nW per cm ² (4.3x10 ⁻⁹ W/cm ²)
Accuracy	see diagram

⁴⁾ Relating to the nominal range, incl. hysteresis and repeatability, determined acc. to the limit point method.

⁵⁾ Time to output the correct level (with max. 10 % deviation) after a sudden level change.

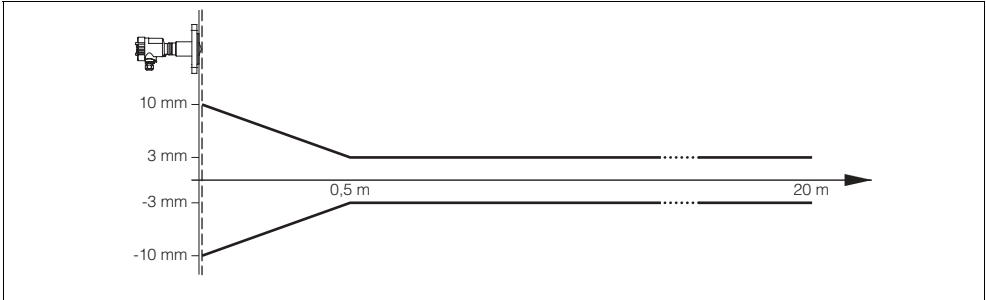

Fig. 30: Accuracy VEGAPULS 63

Ambient conditions

Ambient, storage and transport temperature

- without PLICSCOM -40 ... +80°C (-40 ... +176°F)
- with PLICSCOM -20 ... +70°C (-4 ... +158°F)

Process conditions

vessel pressure depending on the process fitting

- flange up to 2" (from 300 lb)/DN 50 -100 ... 1600 kPa (-1 ... 16 bar/-14.5 ... 232 psi)
- flange from 3" (from 300 lb)/DN 80 -80 ... 1600 kPa (-0.8 ... 16 bar/-11.6 ... 232 psi)
- Tuchenhagen Varivent -100 ... 1000 kPa (-1 ... 10 bar/-14.5 ... 145 psi)
- SMS -100 ... 1000 kPa (-1 ... 6 bar/-14.5 ... 87 psi)

Process temperature depending on the material of the antenna encapsulation (measured on the process fitting)

- TFM-PTFE -40 ... +150°C (-40° ... +302°F)
- TFM-PTFE aseptic, FKM (Viton) -25 ... +130°C (-13 ... +266°F)
- TFM-PTFE aseptic, EPDM -40 ... +130°C (-40 ... +266°F)
- PFA -40 ... +150°C (-40° ... +302°F)

Vibration resistance mechanical vibrations with 4 g and 5 ... 100 Hz⁶⁾

⁶⁾ Tested acc. to the regulations of German Lloyd, GL directive 2

Electromechanical data – version IP 66/IP 67 and IP 66/IP 68, 0.2 barCable entry/plug ⁷⁾

- Single chamber housing
 - 1x cable entry M20x1.5 (cable- \varnothing 5 ... 9 mm), 1x blind stopper M20x1.5
 - or:
 - 1x closing cap ½ NPT, 1x blind stopper ½ NPT
 - or:
 - 1x plug depending on the version, 1x blind stopper M20x1.5

- Double chamber housing
 - 1x cable entry M20x1.5 (cable- \varnothing 5 ... 9 mm), 1x blind stopper M20x1.5, plug M12x1 for VEGADIS 61 (option)
 - or:
 - 1x closing cap ½ NPT, 1x blind stopper ½ NPT, plug M12x1 for VEGADIS 61 (option)
 - or:
 - 1x plug (depending on the version), 1x blind stopper M20x1.5, plug M12x1 for VEGADIS 61 (option)

Spring-loaded terminals

for wire cross sections up to 2.5 mm²**Electromechanical data – version IP 66/IP 68, 1 bar**

Cable entry

- Single chamber housing
 - 1x IP 68 cable entry M20x1.5; 1x blind stopper M20x1.5
 - or:
 - 1x closing cap ½ NPT, 1x blind stopper ½ NPT

- Double chamber housing
 - 1x IP 68 cable entry M20x1.5; 1x blind stopper M20x1.5; plug M12x1 for VEGADIS 61 (option)
 - or:
 - 1x closing cap ½ NPT, 1x blind stopper ½ NPT, plug M12x1 for VEGADIS 61 (option)

⁷⁾ Depending on the version M12x1, acc. to DIN 43650, Harting, Amphenol-Tuchel, 7/8" FF

Connection cable

– Configuration	four cores, one suspension cable, one breather capillary, screen braiding, foil, mantle
– wire cross section	0.5 mm ²
– wire resistance	<0.036 Ohm/m
– tensile load	>1.200 N (270 pounds force)
– Standard length	5 m (16.4 ft)
– max. length	1000 m (3280 ft)
– Min. bending radius	25 mm (with 25°C/77°F)
– Diameter	approx. 8 mm
– Colour – standard PE	Black
– Colour – standard PUR	blue
– Colour – Ex version	blue

Indicating and adjustment module

Power supply and data transmission	through sensor via gold-plated sliding contacts (I ² C bus)
Indication	LC display in dot matrix
Adjustment elements	4 keys
Protection	
– unassembled	IP 20
– mounted into the sensor without cover	IP 40
Materials	
– Housing	ABS
– Inspection window	Polyester foil

Power supply

Power supply	
– non-Ex instrument	14 ... 36 V DC
– EEx ia instrument	14 ... 30 V DC
– EExd ia instrument	20 ... 36 V DC
Permissible residual ripple	
– <100 Hz	U _{ss} <1 V
– 100 Hz ... 10 kHz	U _{ss} <10 mV
Load	see diagram

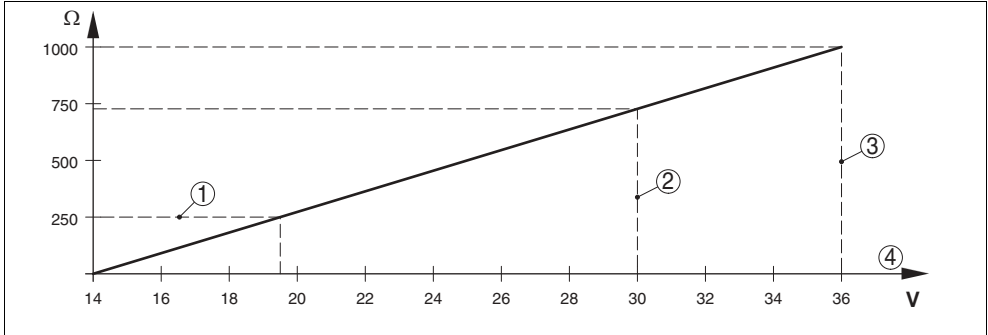

Fig. 31: Voltage diagram

- 1 HART load
- 2 Voltage limit EEx ia instrument
- 3 Voltage limit non-EEx/Exd instrument
- 4 Power supply

Electrical protective measures

Protection

- Plastic housing IP 66/IP 67
- Alu and stainless steel standard IP 66/IP 68 (0.2 bar)⁸⁾
- Alu and stainless housing, optionally available IP 66/IP 68 (1 bar)

Overvoltage category III

Protection class II

⁸⁾ Requirement to maintain the protection is the suitable cable.

Approvals⁹⁾¹⁰⁾

ATEX ia	ATEX II 1G, 1/2G, 2G EEx ia IIC T6
ATEX D	ATEX II 1/2D IP6X T
ATEX ia + D	ATEX II 1G, 1/2G, 2G EEx ia IIC T5 + ATEX II 1/2D IP6X T6
ATEX d	ATEX II 1/2G, 2G EExd ia IIC T6
ATEX d+D	ATEX II 1/2G, 2G EExd ia IIC T5 + ATEX II 1/2D IP6X T
IEC	IEC Ex ia IIC T6; IEC Exd ia IIC T6
FM	FM Cl.I, Div2 (NI)+Cl.II, III, Div1 (DIP); FM Cl.I-III, Div 1 (IS); FM Cl.I-III, Div 1 (IS)+Cl.I-III, Div 1 Gr.C-G(XP)
Ship approvals	GL, LRS, ABS, CCS, RINA
Others	WHG

⁹⁾ Deviating data with Ex applications: see separate safety instructions.

¹⁰⁾ Depending on order specification.

10.2 Dimensions

Housing in protection IP 66/IP 67 and IP 66/IP 68, 0,2 bar

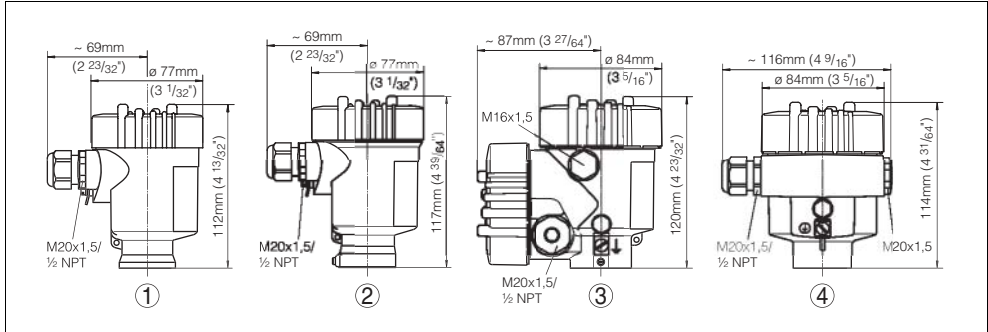

Fig. 32: Housing versions in protection IP 66/IP 67 and IP 66/IP 68, 0,2 bar (with integrated PLICSCOM the housing height increases by 9 mm/0.35 in)

- 1 Plastic housing
- 2 Stainless steel housing
- 3 Aluminium double chamber housing
- 4 Aluminium housing

Housing in protection IP 66/IP 68, 1 bar

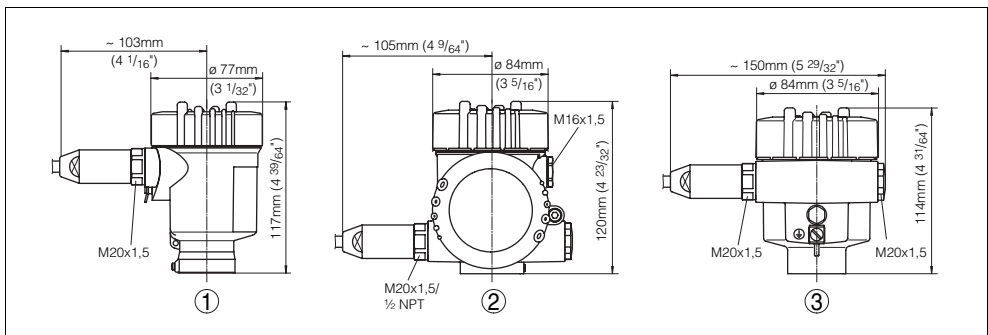

Fig. 33: Housing versions in protection IP 66/IP 68, 1 bar (with integrated PLICSCOM the housing height increases by 9 mm/0.35 in)

- 1 Stainless steel housing
- 2 Aluminium double chamber housing
- 3 Aluminium housing

VEGAPULS 63 – flange version

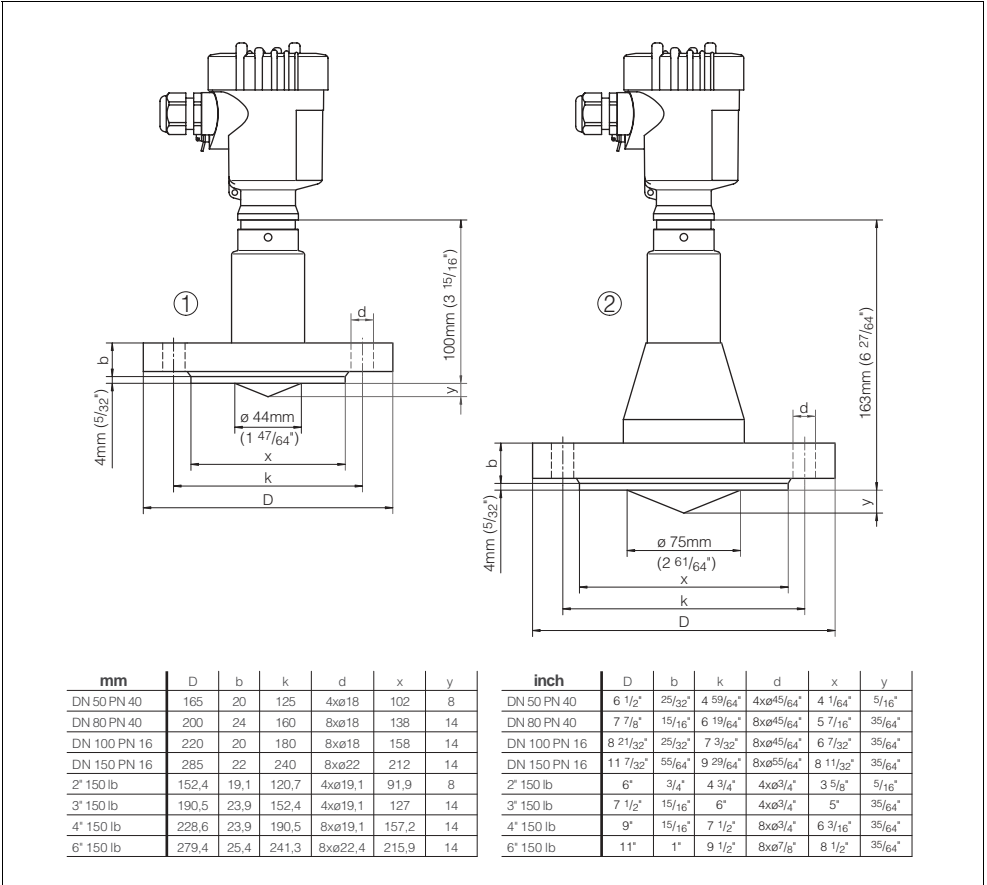

Fig. 34: VEGAPULS 63 – flange version

1 DN 50 and 2"

2 DN 80 ... DN 150 and 3" ... 6"

d = diameter and number of holes in the flange

VEGAPULS 63 – Version NeumoBiocontrol

Fig. 35: VEGAPULS 63 – NeumoBiocontrol hygienic fitting

VEGAPULS 63 – Version Tri-Clamp

Fig. 36: VEGAPULS 63 – Tri-Clamp hygienic fitting

10.3 Certificates

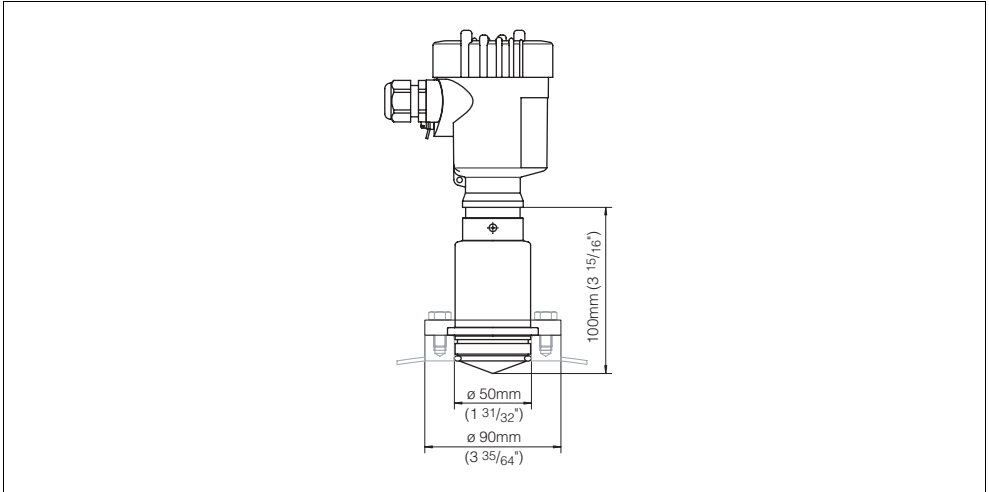
CE declaration of conformity

The image shows a CE Declaration of Conformity certificate for VEGA products. At the top center is the CE mark. Below it, the title 'Konformitätserklärung' is written in German, followed by its English and French translations: 'Declaration of conformity' and 'Déclaration de conformité'. The VEGA logo is prominently displayed in the center. Below the logo, the manufacturer's name and address are listed: 'VEGA Grieshaber KG, Am Hohenstein 113, 77761 Schiltach'. The certificate states that the manufacturer declares sole responsibility for the product's conformity with the following standards: EN 61326:1997 (Class B), EN 61326:1997/A1:1998, and EN 61010-1:2001. The specific products covered are VEGAPULS 61, VEGAPULS 62, VEGAPULS 63, VEGAPULS 65, and VEGAPULS 66, all with a 2-wire HART network interface. The certificate is dated 27.06.2003 and is signed by Josef Fehrenbach, Development Manager, at the Schiltach office.

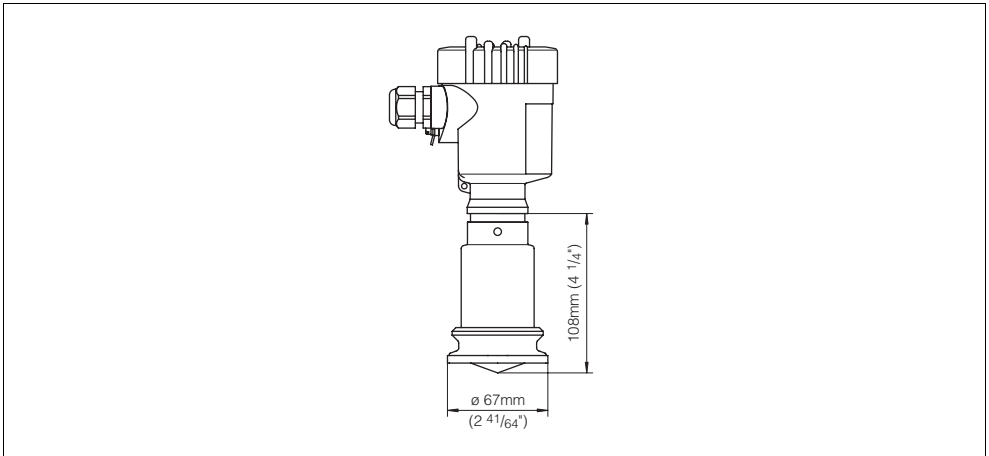
CE

Konformitätserklärung
Declaration of conformity
Déclaration de conformité

VEGA

VEGA Grieshaber KG
Am Hohenstein 113
77761 Schiltach

erklärt in alleiniger Verantwortung, daß das Produkt / declare under
our sole responsibility that our product / déclare sous sa seule
responsabilité que le produit

VEGAPULS 61, VEGAPULS 62, VEGAPULS 63
VEGAPULS 65, VEGAPULS 66
mit 2Leiter HART-Netzteil

auf das sich diese Erklärung bezieht, mit den folgenden Normen
übereinstimmt / to which this declaration relates is in conformity
with the following standards / auquel se réfère cette déclaration
est conforme aux normes

EN 61326 : 1997 (Klasse B)
EN 61326 : 1997 / A1 : 1998
EN 61010 – 1 : 2001

gemäß den Bestimmungen der Richtlinien / following the provision
of Directives / conformément aux dispositions des Directives

73/23 EWG
89/336 EWG
93/68 EWG

Schiltach, 27.06.2003 *p.p.a. J. Fehrenbach*

Josef Fehrenbach
Entwicklungsleitung

Fig. 37: CE declaration of conformity

Manufacturer declaration

VEGA

Manufacturer declaration no. 24626

Messrs. VEGA Grieshaber KG
Am Hohenstein 113
77761 Schiltach

declares that the **Radar Sensor Type VEGAPULS 61, 62, 63, 65, 66, 68
with electronics "H" 4 ... 20mA HART**

in accordance with DIN/EN 60079-14/2004 paragraph 5.2.3 item c 1

and when used correctly under the condition that the operator follows the instructions in the documents listed:

- Mounting and operating instructions in the Operating Instructions manual
- Data and instructions of this manufacturer declaration
- Installation regulations

are suitable for use in **Zone 2**

The max. surface temperature increase* during operation is 27K.

With an ambient temperature of 70°C on the housing and a process temperature of 70°C, the max. surface temperature* is 97°C during operation.

Measures to maintain the explosion protection during operation:

- This declaration is only applicable if VEGAPULS is operated within the stated electrical threshold values.
- Permissible operating voltage: U=14...36 V DC (VEGAPULS 68: U=15...36 V DC)
- The instrument must be installed and operated in such a way that ignition due to electrostatic charge is not expected (depending on the version, the antenna, process fitting or the housing are made of electrically non-conductive plastic).
- The availability, the perfect quality and the correct position of the seal between the lower part of the housing and the cover must be ensured; the cover must be screwed on tightly.
- If the instrument is operated with opened cover, the adjustment module PLICSCOM is mounted or its keys are pushed, it must be ensured that no explosive atmosphere is present.
- Make sure that the cable entry is tight and strain-relieved; the outer diameter of the connection cable must be adapted to the cable entry; the pressure screw of the cable entry must be tightened carefully.
- Free openings for cable and cable entries must be covered tightly.
- VEGAPULS must be mounted in such a way that contact of the sensor to the vessel wall can be excluded by taking vessel installations and flow conditions in the vessel into account.
- The surface temperature must not exceed the ignition temperature of the concerned explosive atmosphere.

*Single component in the instrument

This instrument was judged by a person meeting the requirements acc. to DIN/EN 60079-14.

VEGA Grieshaber KG
Schiltach, den 19.05.05



Fig. 38: Manufacturer declaration



All statements concerning scope of delivery, application, practical use and operating conditions of the sensors and processing systems correspond to the information available at the time of printing.