



USERS MANUAL



EchoTREK

S-300 compact ultrasonic level transmitter series for free flowing solids

Issue August 28, 2001

Transmitter programming is performed in accordance with the 3d edition of the INSTALLATION and PROGRAMMING MANUAL

Distributed exclusively in the U.S.A. by

HiTECH Technologies, Inc.

**301 Oxford Valley Road, Building 505
Yardley, PA 19067-7706**

1-800-755-4507

www.hitechtech.com



ULTRASONIC LEVEL SOLIDS MEASUREMENT PRINCIPLES

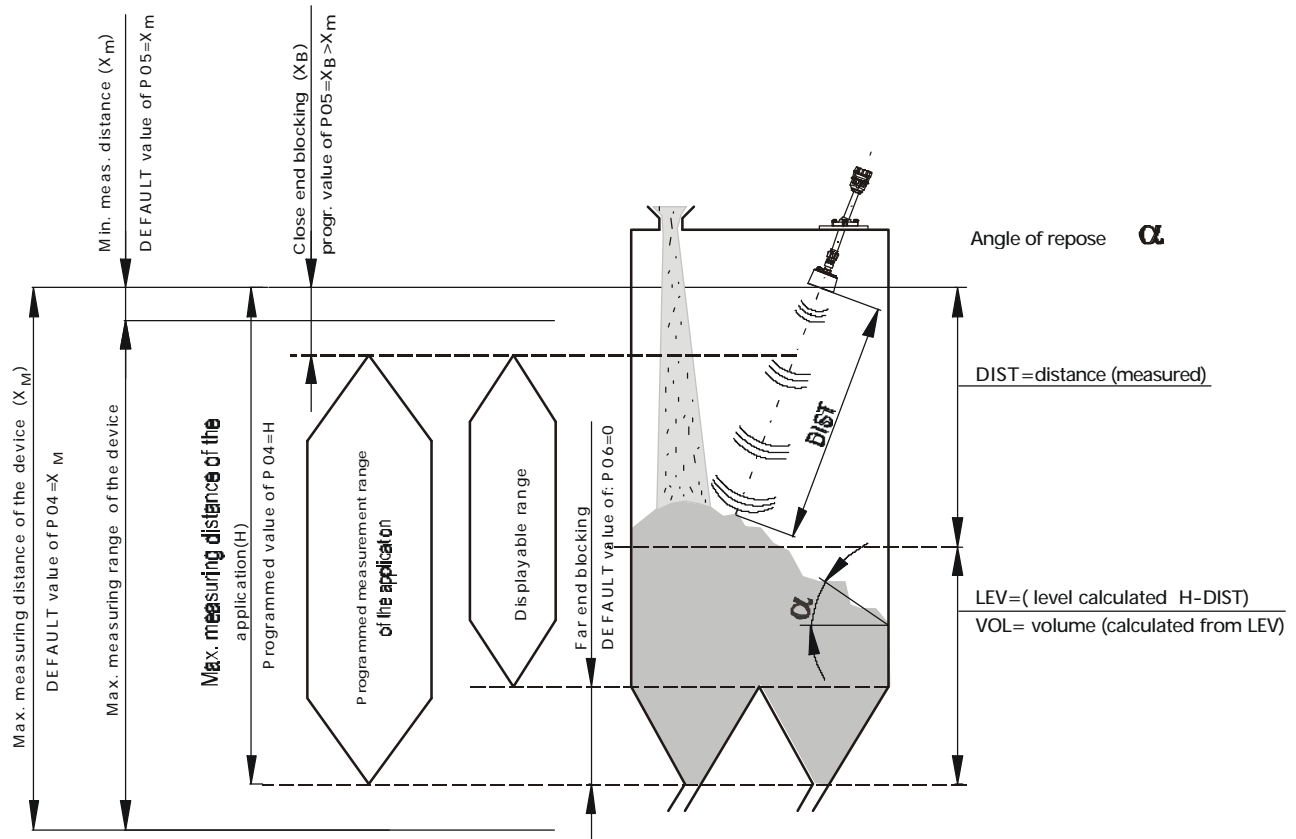

1. APPLICATION

APPLICATION

The EchoTREK SBD/STD-300 series of compact ultrasonic level transmitters from HiTECH/NIVELCO are designed to measure the level of the most free flowing solids (powders and granules).

This intelligent microprocessor based smart level transmitter offers scaleable 4-20 mA output, programmable relay and HART communication.

Level measurement based on non-contacting ultrasonic technology is especially suited for applications where, no physical contact can be established to the surface of the material to be measured and/or moving parts are to be avoided to eliminate mechanical wear-out.

PRINCIPLE OF OPERATION

The ultrasonic level technology is based on the principle of measuring the time required for ultrasound pulses to make a round trip from the sensor to the level to be measured and back.

The sensor emits an ultrasonic pulse and receives the echoes reflected. The intelligent electronics processes the received signal by selecting the echo reflected from the surface, and calculating from the time of flight, the distance between the sensor and the surface, which constitutes the basis of all output signals of the Echo TREK!

X	D
5 m	0,7 m
10 m	1,2 m
20 m	2 m
30 m	3 m
40 m	3,8 m
50 m	4,7 m

Foot prints corresponding to 5° beam angle.

A Total beam angle of 5° at -3 dB is a key feature of all HiTECH/Nivelco's SonicLaser ultrasonic transducers.

This unique narrow beam angle ensures reliable measurement in narrow silos with uneven sidewalls and even in the presence of dusting. Furthermore, as a result of the narrow beam angle – the emitted ultrasonic signals have an outstanding focusing – a sufficient signal penetration through dust is ensured.

Minimum measuring distance (X_m): (also known as the "Dead Band") is a feature common to all ultrasonic level transmitters. This is a short range in front of the sensor within which the ultrasonic device cannot measure.

Maximum measuring distance (X_M): The longest range under ideal condition within which the device can measure. No measurement is possible beyond this distance.

2. TECHNICAL DATA

GENERAL DATA

Product name	EchoTREK STD/SBD-300 series
Sensor material	Closed cell Polyurethane foam sensor face (PUR), Polypropylene sensor housing, Aluminum mounting accessories
Housing material	Epoxy powder coated Aluminum
Process temperature	-22°F – 167°F (-30°C ... +75°C)
Ambient temperature	-22°F – 140°F (-30°C ... +60°C), with SAP-100 programming module –77°F – 140°F (-25°C ... +60°C)
Pressure (Absolute.)	0.7 ... 1.1 bar (0,07 ... 0,11 MPa) and ± 0.1 bar (0.01 MPa) difference between outside and internal silo space
Mechanical protection	Sensor: IP65 (NEMA 5), Housing: IP67 (NEMA 4X)
Power supply / Consumption	Version I: 120 ... 375 V DC / 5,5 W 85 ... 255 V AC (50/60 Hz) / 6.8 VA ; Version II: 10.5 ... 40 V DC / 4.1 W 10.5 ... 28 V AC (50/60 Hz) / 4.6 VA
Accuracy*	± (0.2% of the measured distance plus 0.1% of the maximum measuring distance of the device)
Resolution	1/3" (10 mm)
Outputs	Analog: 4 ... 20 mA, max. 600 Ohm, galvanically isolated, over voltage protection
	Relay: SPDT, 250 V AC / 3 A, AC1
	Display (SAP-100): 6 digits, icons and bargraph, Custom LCD
	Digital communication: HART, MODBUS
Electrical protection	Class I.
Electrical connections	2 x Pg16 and 2 x 1/2" NPT for wire cross sections: 0.5 ... 2.5 mm²

* Under optimal circumstances of reflection and stabilised sensor temperature.

TYPE SPECIFIC DATA

Type	STD-34J SBD-34J STD-34X SBD-34X	STD-33J SBD-33J STD-33X SBD-33X	STD-31J SBD-31J STD-31X SBD-31X
Maximum measuring distance* (X _m) m/feet	8/26	25/82	50/164
Minimum measuring distance* (X _m) m/feet	0.6/2	0.6/2	1/3,33
Total beam angle (at -3dB)	5°		
Measuring frequency	30 kHz		15 kHz
Weight	15 lbs. (7 kg)		22 lbs. (10 kg)

* Measured from the sensor face

SAP-100 PROGRAMMING AND DISPLAY MODULE

Field indication	6 digits, icons and bargraph, Custom LCD
Ambient temperature	-13° F – 140°F (-25°C ... +60°C)
Housing material	PBT fiber-glass reinforced plastic, flame-retardant (DuPont®)

2.1 ACCESSORIES

- User's Manual
- Installation and Programming Manual 3d edition
- Warranty card
- EView Light configuration software and description on CD (for types of S□□- 3□□-3/4 only)
- 2 each Pg 16 cable gland

ACCESSORIES TO BE ORDERED

- Split flange (order code: SFA – 3□□)
- SAP-100 programming module
- EView configuration software CD

2.2 ORDER CODES

EchoTREK S D - 3 -

Type	Code
Transmitter	T
Transmitter + Local Indicator	B

Range	Code
50 m	1
25 m	3
8 m	4

Application	Code
Normal	J
Dust Ex	X

Power supply / Output	Code
Version I. 85 ... 255 V AC 120 ... 375 V DC	
4 ... 20 mA + Relay	1
4 ... 20 mA + Relay + HART	3
RS 485 (MODBUS protocol) + Relay	5
Version II. 10,5 ... 28 V AC 10,5 ... 40 V DC	
4 ... 20 mA + Relay	2
4 ... 20 mA + Relay + HART	4
RS 485 (MODBUS protocol) + Relay	6

2.3 DIMENSIONS

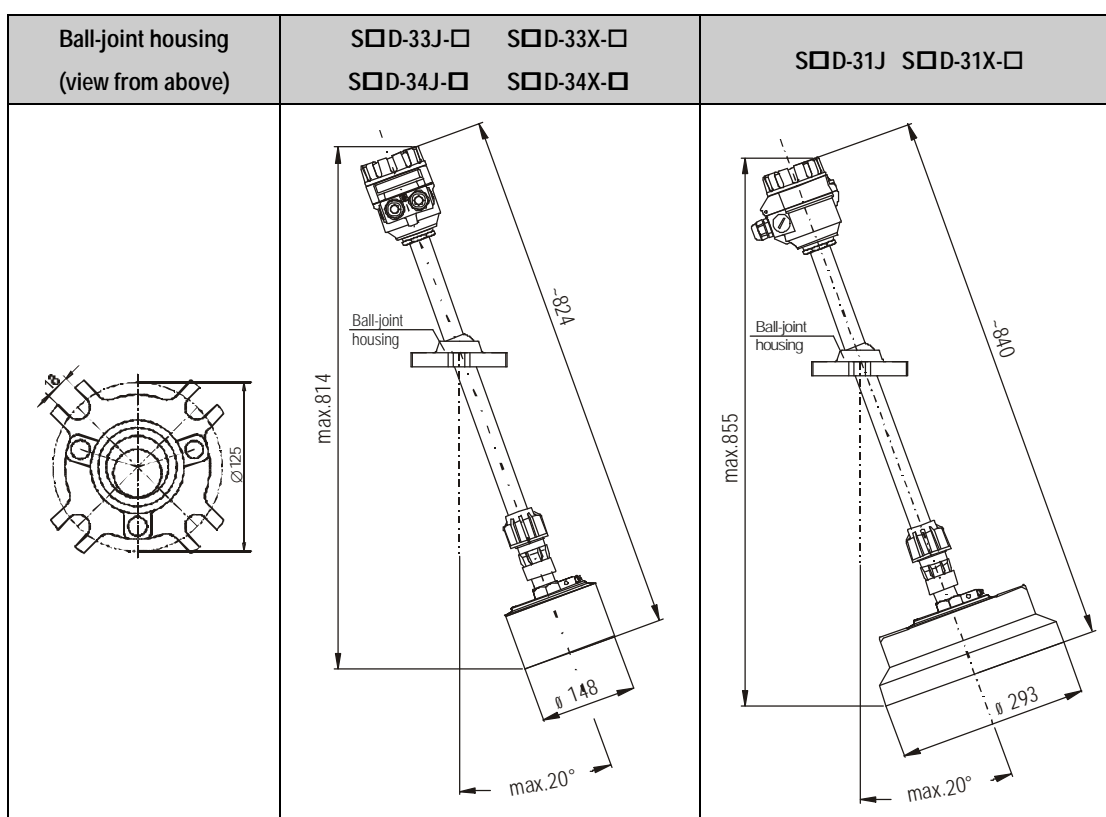

3. INSTALLATION

POSITIONING

Selecting optimal location for the transmitter various considerations should be made.

If the measured material is granule (material size > 5 mm) and the tank roof is dome shaped or conical, do not install the transmitter in the center of the tank/silo.

In general the transmitter can be installed on the radius $r = (0,3 \dots 0,5) R$.

Avoid that the 5° conical beam angle of the transmitter contact the tank/silo wall. In case the transmitter is mounted close to the wall, it should be tilted (See section "Aiming"). Protect the transmitter electronics from overheating due to direct sunshine.

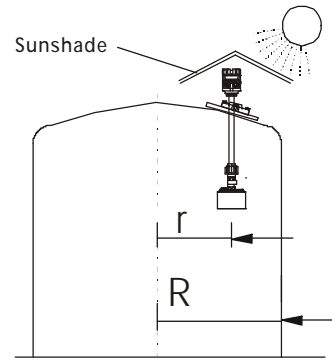

GRAVITY FILLING

Select a location that is as far away from the filling point(s) as possible.



PNEUMATIC FILLING

Select a location where the speed of the in-flowing material is the smallest.

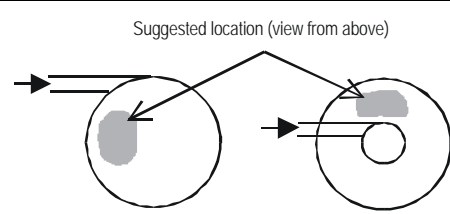

MOUNTING (See illustration for mounting)

The EchoTREK consists of a sensor that is attached to the aiming arm (a pipe with a ball-joint housing incorporating a ball joint) that is attached to the housing of the electronics. It is recommended to mount the transmitter on the roof of the tank/silo using a flange (See drawing). The Ball-joint housing has a screw-hole diameter of 125 mm for fixing it. For easy installation we recommend to use our special flange with a split insertion, available with four sizes of DN125/150/200/300 (to be ordered separately). Removing the split insertion, the flange is to be put around the aiming arm and the ball-joint housing is to be fixed to the split flange. It is essential to use the washers and the bolts (4 each) delivered with the split flange. The ball-joint will be pressed to the housing by a spring allowing adjustment/aiming. The 4 each of M12 bolts only has to be tightened after completing the adjustment/aiming.

Mounting EchoTREK versions S□□-33J and S□□-34J

1. Check the split flange for matching the boreholes with that of the counter-flange on the silo
2. Remove the split insertion from the flange and put the flange around the aiming arm between the sensor and the Aluminum base.
3. Slide the split insertion back to its place and screw the ball-joint housing to the flange with the 4 each M 12 bolts to such an extent that will allow free movement of the aiming arm through and tilting by the ball joint for the aiming process.
4. Pass the sensor through the opening cut on the roof and fasten the flange to its place.
5. Perform the aiming (See section "Aiming" below).
6. For fixing the position of the aiming arm, tighten the 4 (M 12) bolts of the ball-joint housing (Max. 3.5 Nm).

Mounting EchoTREK S□D -31□ versions, with silo/tank roof opening of Ø 11.81" (300 mm)

The procedure is the same as above but the flange diameter is 12".

Mounting EchoTREK S□D -31□ version with silo/tank roof opening less than Ø 11.81" (300 mm) and the silo space is accessible from inside

1. Check the split flange for matching the boreholes with that of the bolt places or counter-flange on the silo
2. Place the sealing below the flange (if necessary)
3. Push the unit out of the silo (upwards) (See on the next page)
4. Is the Aluminum base with the ball-joint over the counter-flange the special flange has to be placed around the aiming arm (See on the next page)
5. Put the split flange on the counter-flange and lower the ball-joint housing on it
6. Slide the insertion to its place (See on the next page)
7. Screw in the 4 (M12) bolts (See on the next page) to such an extent that will allow free aiming
8. Fasten the EchoTREK (with the split flange) to the counter-flange or to the roof of the silo/tank.
9. After completing aiming tighten the 4 (M12) bolts (Max. 3.5 Nm).

If the entire tilting range of the aiming arm is required, the thickness of the roof cannot exceed as specified on the above drawing.

The EchoTREK can also be mounted on existing (manhole) covers, access lids or for instance on a steel structure lowered into a larger (ex.: 0.5 x 0.5 m) opening on the roof. This solution is to be used with roof stronger than 350 ... 380 mm.

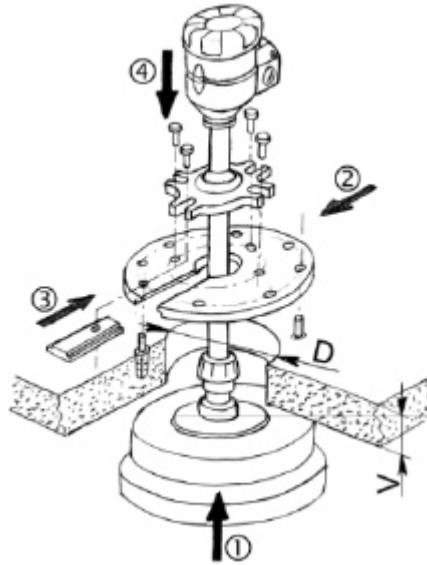

Illustration for mounting

Diameter of the opening D	Thickness of the roof V
160 mm	110 mm
190 mm	150 mm
230 mm	200 mm
300 mm	280 mm
340 mm	300 mm

AIMING OF THE ECHOTREK

To reduce weak signal reflection from the material surface caused by an angle of repose building due to the filling and/or emptying process, it is recommended to tilt the sensor by the aiming arm of the transmitter.

Aiming is best carried out during operation, when the tank/silo is almost empty. In most cases, the sensor should be aimed towards the middle of the tank/silo bottom by aiming at the silo outlet. In applications where repose is not present or with tall and narrow silos (diameter/height

5) aiming is not critical: the sensor should face straight downward. Aiming is also aided by the informational parameters P70 ... P 75 (see Programming Manual). Aiming should also be tested with full silo, since due to the great angle of repose the echo might be weak despite of the fact that level is near to the sensor. In such cases a reasonable compromise of aiming should be achieved that provide acceptable echo in every state of the filling.

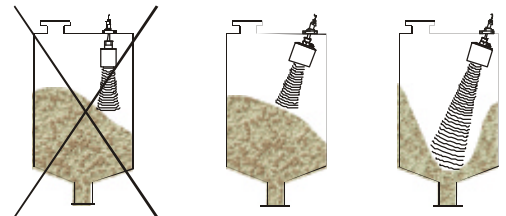

4. ELECTRICAL CONNECTIONS

- To access the electric connection point, unscrew the bolt on the side of the electronics housing. Use cable with a wire cross-section of 0.5 ... 2.5 mm².
- Electric connection may be carried out using either a single cable or two cables. Wires in different groups (A, B, C; shown below) must not be led in the same cable.

Group A	Group B	Group C
Low voltage power supply	4 ... 20 mA. Selv voltage power supply	RS485 (shielded twisted pair)
Low voltage for the relay	Selv voltage power or logic signal for the relay	

- Devices must be grounded either at the internal or external grounding screw terminals depending on the way of cabling.
- DC powered devices can be 3-wire connected. In this case the terminals "1" and "6" must be interconnected. In this case the galvanic isolation will not be provided!
- After performing the electric connections, check for correct sealing and close the housing.

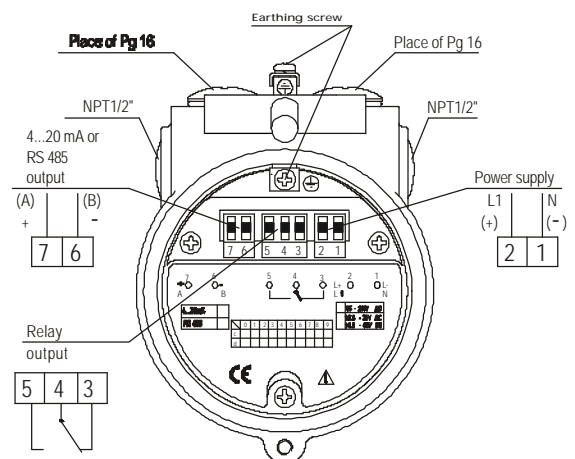

Wiring diagram

Space for the wiring, for better overview without upper part

5. PROGRAMMING

Modification of the parameters (programming) is required to customise the transmitter to the actual parameters of the tank/silo.

Programming of the EchoTREK is described in the Installation and Programming Manual (3d edition)!

Programming can be performed using the plug-in programming/indicator module SAP-100. EchoTREK's of series SB□-3□□ contain this module. The programming/indicator module can be plugged or unplugged even while the unit is powered up.

The programming module can be accessed by un-screwing the cover. The EchoTREK can work without the programming module.

Units with HART or RS485 communication can be fully programmed by digital communication. Necessary information for these units will be provided both in printed form and on CD.



Electrostatic discharge caused by touching the terminals of the SAP-100 programming module may cause damage to the device. Avoid this by common means of preventing electrostatic discharge (ex. by touching a grounded point before opening the device).

The STD/SBD EchoTREK series for solids cannot be programmed by magnet!

6. MAINTENANCE, REPAIR

The device does not require routine maintenance. In case dust adheres to the face of the sensor despite the self-cleaning of the sensor face through resonance, (ex.: static build-up) it can be cleaned by pressurised air.

Equipment sent back for repair should be cleaned or sterilized by the User. The User must declare that the above has been carried out.

HiTECH must perform all repairs, both during and/or beyond the guarantee period.

7. STORAGE CONDITIONS

Environmental temperature range: -30 ... +60°C

Relative humidity: max. 98 %

8. WARRANTY - PERFORMANCE GUARANTEE

Since 1986, every instrument sold by **HiTECH** has been guaranteed to perform in the application it originally was engineered and recommended for. Our company policy remains the same, every product sold comes with a **written performance guarantee**.

Should the equipment be unable to perform satisfactorily in your application and we are not able to correct the problem, we will accept the instrument in return and issue full credit.

This performance guarantee is valid for 60 days. Thereafter, our standard limited two years factory warranty goes into effect.