

HiTECH

Technologies, Inc.

EchoTREK™
THE NEXT GENERATION

SMART

SOLIDS LEVEL TRANSMITTERS

SonicLaser™ Sensing Technology

Model Sxx-34J

LEVEL MEASUREMENT up to 50 Feet

Powders and Bulk Solids

Carbon Black - Fly Ash

Cement - Lime - Sand

Grain - Flour - Sugar

Coal - Coal Powder

Plastics

Unique Foam Sensor
Specially Designed for
Solids Sensing

Innovative
Aiming System

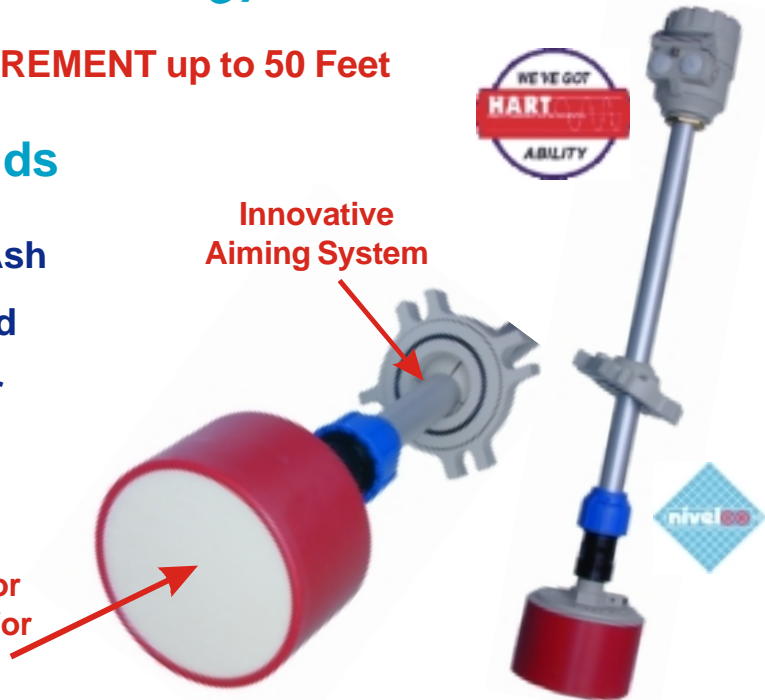

ADVANTAGES

- Simple programming
- 4 to 20ma PLUS programmable relay outputs
- 32-point linearization
- 2 x Fixed target suppression
- Built-in temperature sensor provides compensation
- Several operating modes:

Basic: Simple start up and 4/20 mA programming using a supplied magnet

Sophisticated: Plug-in programming module includes 5 digit LCD display, choose between a menu driven QUICKSET, full parameter programming or a simple calibration of the analog output.

Digital: For remote information transfer and programming: HART protocol is available.

EchoTREK™ is HiTECH's new line of SMART level transmitters incorporating the unique SonicLaser™ technology, combined user selectable digital algorithms and optional HART protocol.

EchoTREK™ compact transmitters include the latest version of the field proven QUEST II™ advanced, process adaptive signal processing software to identify and validate the signal echo.

HiTECH's SonicLaser™, utilizing unique patented technology, is the best available ultrasonic level measurement system on the market today. Presently there are over 20,000 narrow beam **SonicLaser™** sensors, successfully operating worldwide, in various harsh industrial processing environments



HiTECH Technologies, Inc.

301 Oxford Valley Road, Yardley, PA 19067-7706

Technical support: 800. 755. 4507

Tel: 215. 321. 6012 ~ Fax: 215. 321. 6067 ~ www.hitechtech.com

HITECH

Technologies, Inc.

EchoTREK™
THE NEXT GENERATION

SMART

SOLIDS LEVEL TRANSMITTERS

Model Sxx-34J

SPECIFICATIONS

Application	Medium sized Silos containing Powders or Granular materials
Measurement Range	Up to 50 feet
Frequency	30 KHz
Total beam angle @ -3dB	5 °
Process Temperature	- 22 °F to + 167 °F
Mounting	Aimer with various flanges available
Enclosure Sensor: Housing:	NEMA 4X & 6 NEMA 4
Sensor Materials	Paint coated Aluminum with Unique foam face
Housing Materials	Plastic or Powder coat die-cast Aluminum
Supply Voltage (3/4-wire versions)	80 to 255 V AC 50/60 Hz or 10.5 to 40 V DC and 10.5 to 28 V AC
Outputs	Analog 4 to 20 mA isolated Relay SPDT 250 V AC @ 3 A Digital HART® protocol (optional)

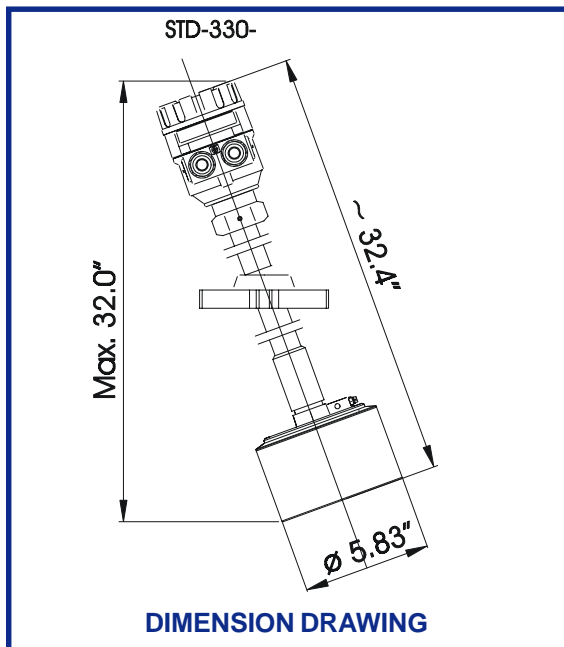

PERFORMANCE GUARANTEE

Since 1986, every instrument sold by **HITECH** has been guaranteed to perform in the application for which it was originally engineered and recommended. Our policy remains the same, each product sold comes with a **written performance guarantee**.

Should the equipment be unable to perform satisfactorily in your application and we are not able to correct the problem, we will accept the instrument in return and issue full credit.

This performance guarantee is valid for 60 days. Thereafter, our standard limited two years factory warranty goes into effect.



Copyright HITECH Technologies, Inc.2003

HITECH Technologies, Inc.

301 Oxford Valley Road, Yardley, PA 19067-7706

Technical support: 800. 755. 4507

Tel: 215. 321. 6012 Fax: 215. 321. 6067 www.hitechtech.com