



EasyTREK

SCD-300 compact ultrasonic level transmitter
series for free flowing solids

INSTALLATION and PROGRAMMING MANUAL

1st edition

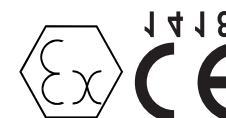

HiTECH/NIVELCO Process Control Co.

301 Oxford Valley Road, Bldg 505, Yardley, PA 19067 Tel: (215) 321-6012 ♦ Fax: (215) 321-6067

E-mail: info@hitechtech.com ♦ www.hitechtech.com

PRINCIPLES OF ULTRASONIC LEVEL MEASUREMENT

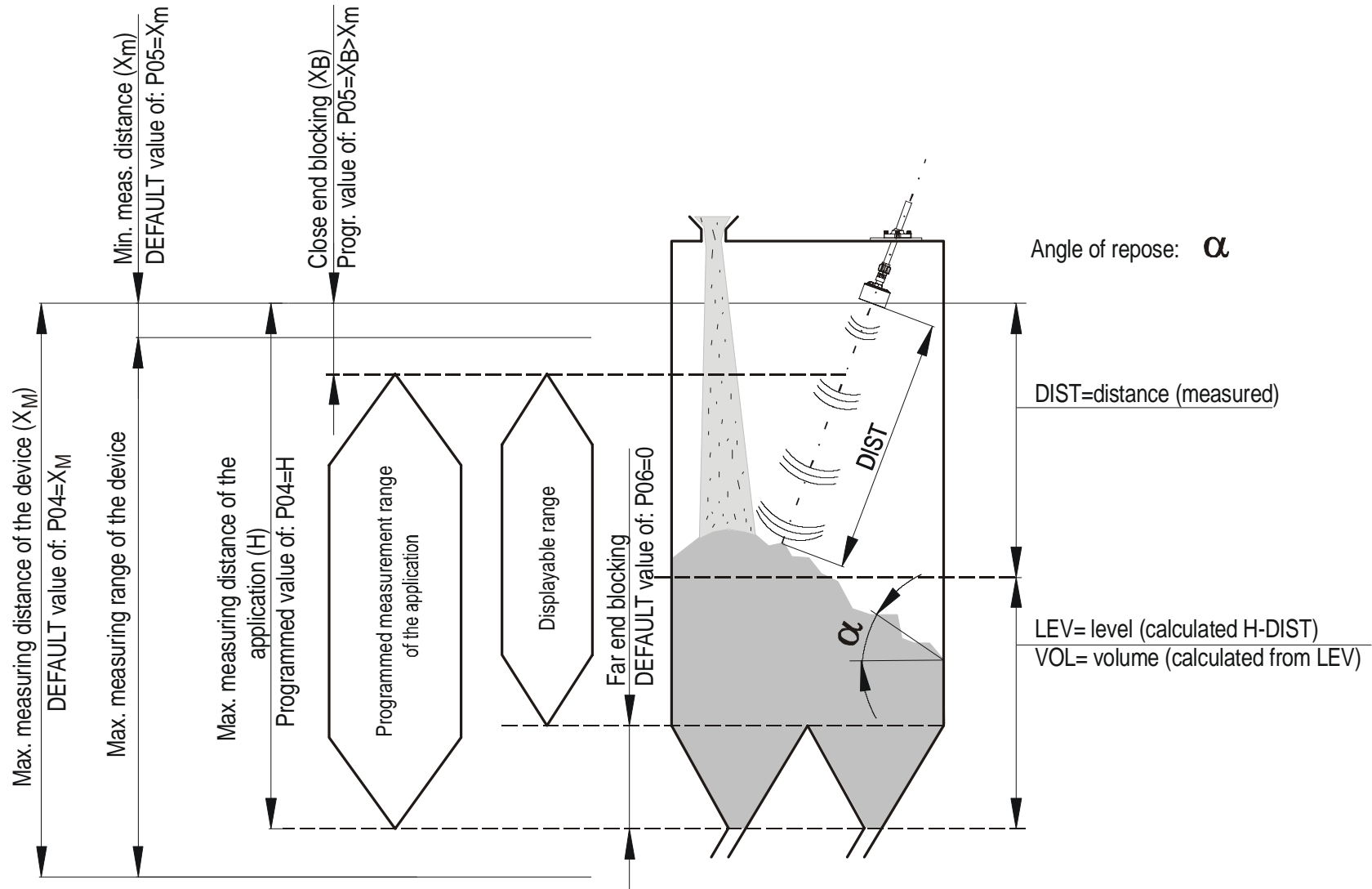

CONTENTS

1. INTRODUCTION	5	6. MAINTENANCE, REPAIR	33
2. TECHNICAL DATA	7	7. STORAGE CONDITIONS	33
2.1. GENERAL DATA	7	8. PARAMETER TABLE.....	34
2.2. SPECIAL DATA.....	7		
2.3. ACCESSORIES.....	8		
2.4. ORDER CODES	8		
2.5. DIMENSIONS	9		
3. INSTALLATION.....	10		
4. WIRING.....	12		
4.1. WIRING CONDITIONS.....	12		
4.2. CONNECTION CABLE EXTENSION	12		
5. PUTTING INTO OPERATION, ADJUSTING, PROGRAMMING ..	14		
5.1. PUTTING INTO OPERATION	14		
5.1.1. <i>Status indication signals in measuring mode</i>	15		
5.2. SAFETY REGULATIONS OF THE EX APPROVED UNITS	15		
5.3. PROGRAMMING	15		
5.4. PARAMETERS – DESCRIPTION AND PROGRAMMING.....	16		
5.4.1. <i>Measurement Configuration</i>	16		
5.4.2. <i>Current value</i>	21		
5.4.3. <i>Relay output</i>	22		
5.4.4. <i>Measurement optimization</i>	23		
5.4.5. <i>Volume measurement</i>	28		
5.4.6. <i>Linearisation</i>	29		
5.4.7. <i>Informational parameters</i>	30		
5.4.8. <i>Test parameters</i>	31		
5.4.9. <i>Error codes</i>	32		

*Thank you for choosing a HiTECH/ NIVELCO instrument.
We are sure that you will be satisfied throughout its use.*

1. INTRODUCTION

APPLICATION

The EASYTREK SCD - 300 series compact ultrasonic transmitters from HiTECH/NIVELCO are designed to measure the level of free flowing solids, granules and powders.

The unit does not touch the material to be measured and does not include any moving parts. Thus, it is not exposed to mechanical loading, no abrasive effect is expected and regular maintenance is not required.

A Total beam angle of 5° at -3 dB is a feature of all HiTECH/NIVELCO's ultrasonic sensors designed for the level measurement of free flowing solids. This uniquely narrow beam angle ensures reliable measurement in narrow silos with uneven side walls or sometimes even in the presence of dusting.

Furthermore, as a result of the narrow beam angle – the emitted ultrasonic signals have an outstanding focusing – a sufficient signal penetration through dust is ensured.

PRINCIPLE OF OPERATION

The ultrasonic level metering technology is based on the principle of measuring the time required for the ultrasound pulses to make a round trip from the sensor to the level to be measured and back.

The sensor emits an ultrasonic pulse train and receives the echoes reflected. The intelligent electronic device processes the received signals by selecting the echoes reflected from the surface and calculates the distance from the time of flight between the sensor and the surface of the medium. This is the basis for all other output signals (level or volume) of the EasyTREK! For measuring the level of the medium the greatest distance of the application (H) has to be programmed.

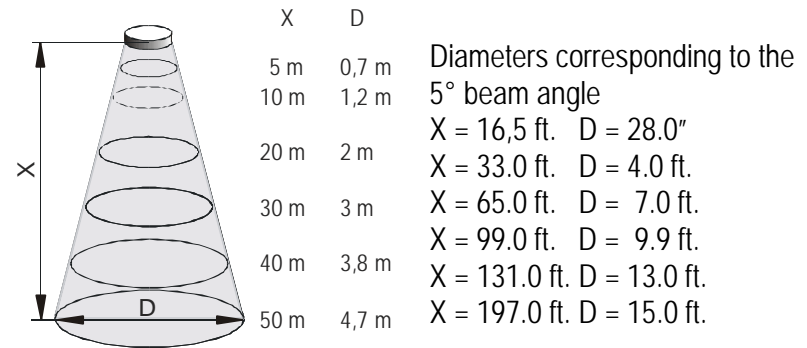

Minimum measuring distance (X_M) is the construction defined smallest distance within which measurement is not possible (Dead Band; see 5.3. Parameters P05). In special applications this range should be extended with programming (close end blocking)

Maximum measuring distance (X_M): is the construction defined greatest distance, which can be measured by the unit under ideal conditions. No measurement is possible over this distance i.e. maximum distance of the application H must not be greater than X_M . Under unfavourable circumstances such as bad reflection or heavy dusting of the material the measuring capability may be reduced up to the half of the unit's best performance.

THE FOLLOWING TYPES OF APPLICATIONS ARE POSSIBLE DEPENDING ON THE COMMUNICATION AND WHAT THE OUTPUT SIGNAL IS USED FOR:

1. Using the unit as a three - or four -wire current transmitter.

Normally, we use the analogue (4...20 mA) output signal of the EasyTREK. The application parameters of the device are set through HART communication at installation (right after installation or in a laboratory, prior to installation). In this case the short address of the device should stay the factory default: P19 = 0.

2. Using both, current transmission and digital (HART) signal transfer in single transmitter systems.

Digital signal transfer is also used beside the standard utilisation of the output current of the EasyTREK. In this case, there can be one or more devices in the current loop that use analogue signals (with their total resistance being $R_t = 250 \dots 600 \Omega$) and one HART master device.

The short address of the EasyTREK should stay the factory default: P19 = 0. This application can be achieved with using a PE□-1□0 or a PR□-1□ type MultiCONT unit as the HART master which ensures the power supply of the EasyTREK too.

3. Simultaneous control of several EasyTREK transmitters with the help of a MultiCONT.

In this case all of the EasyTREK s keep the connection with the MultiCONT through HART communication only.

This means that the measurement values are collected in cycles, and that the modifications of the transmitter settings are arbitrary.

The short addresses of the units are P19 = 1 ... 15. All types of setting and programming tasks can be done through a MultiCONT.

2. TECHNICAL DATA

2.1. GENERAL DATA

Type	EasyTREK SCD- 3□□ - 4	EasyTREK SCD- 3□□ - 8 Ex*
Housing material	PP+ Aluminium	Aluminium
Total beam angle (-3dB)	5°	
Process temperature	-22°F (-30°C) ... + 140°F (60°C)	- 4°F (-20°C) ... +140°F (60°C)
Process pressure (absolute)	0,07 ... 0,11 MPa (0,7 ... 1,1 bar) 10 PSI – 16 PSI	
Power supply / consumption	11,4 ... 40 V DC / 3,6 W, 11,4 ... 28 V AC / 4 VA	
Output	Analogue	4 ... 20 mA, R _{tmax} = 600 ohm, Galvanic isolation; protection against surge transients
	Digital communication	HART
	Relay	SPST ; 48 V AC / 5A; A12
Accuracy	±(0,2% of the measured distance + 0,1% of the range)	
Resolution	0.39" (10 mm)	
Damping	3 ... 1000 s	
Electric connection	6 x 2,5 mm ² Ø 7,5 mm shielded cable ; standard length 9.8 ft (3 m) ; (to order up to 98 ft. (30m)	
Electric protection	Class III	
Ingress protection	IP65	
Ex marking*	n.a.	ATEX  II 1D IP 65 T 130 °C

*Pending

2.2. SPECIAL DATA

Type	SCD-34□ - 4 SCD-34□ - 8 Ex*	SCD-33□ - 4 SCD-33□ - 8 Ex*	SCD-31□ - 4 SCD-31□ - 8 Ex*
Maximum measuring distance** (X _M)	49 ft. (15 m)	98 FT. (30 m)	197' (60 m)
Minimum measuring distance** (X _m)	1.6 ft. (0,5 m)	2 ft. (0,6 m)	3.28 FT. (1 m)
Ultrasound frequency	40 kHz	30 kHz	15 kHz
Sensor face	PVC foame		
Mass	7.7 lbs. (~ 3.5 kg)	7.7 lbs. (~ 3.5 kg)	14.0 lbs. (~ 6.5 kg)

**Under optimal circumstances of reflection and stabilised sensor temperature

2.3. ACCESSORIES

- Installation and Programming Manual
- Guaranty Certificate
- Manufacturer's Declaration
- EView Light configuration software and description on CD

ACCESSORIES TO BE ORDERED

- Split flange (order code: SFA – 3□5)
- EView configuration software CD
- HART modem

2.4. ORDER CODES

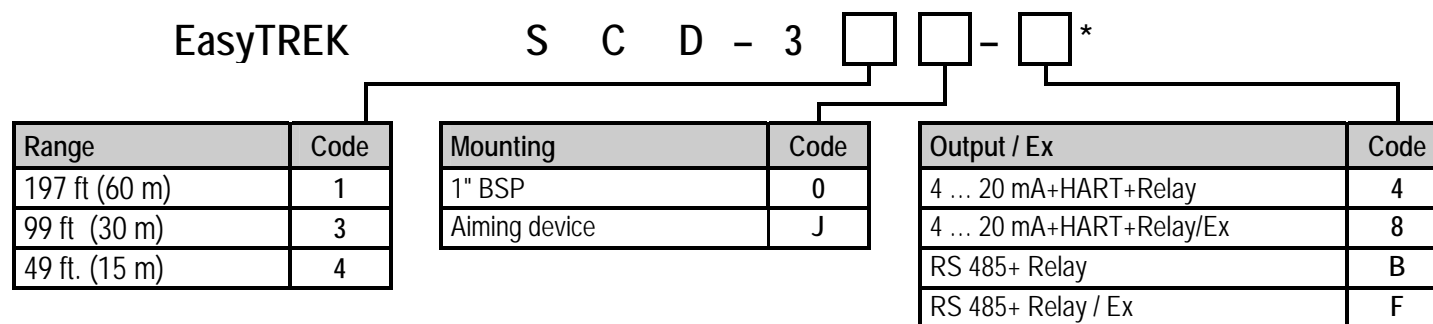

* The order code of an Ex version should end in "Ex"

2.5. DIMENSIONS

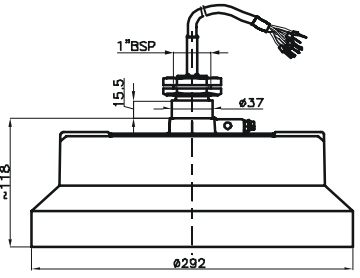
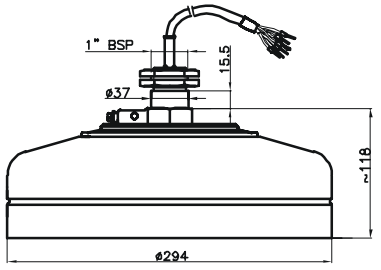
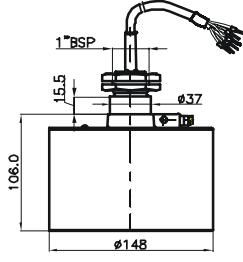
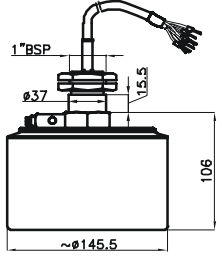
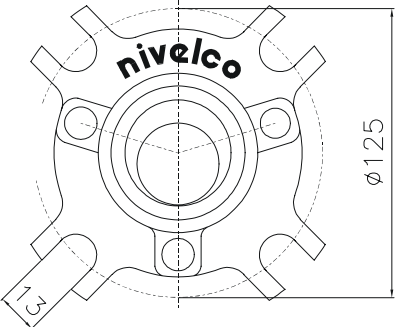
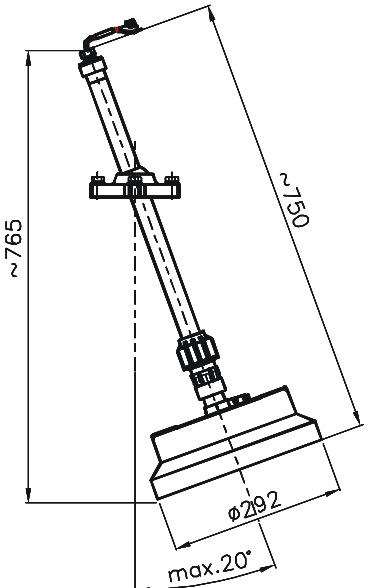
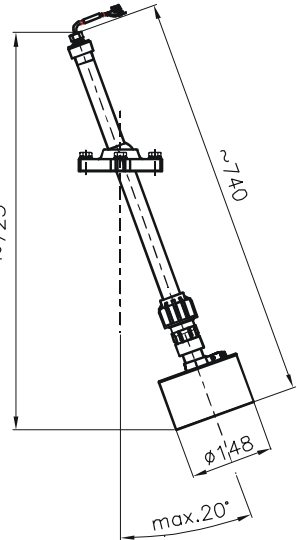
SCD-310- __	SCD-310- __ Ex	SCD-330- __ SCD-340- __	SCD-330- __ Ex SCD-340- __ Ex	
 <p>Technical drawing showing the front view of the SCD-310- sensor head. It features a 1" BSP connection, a height of approximately 118 mm, and a diameter of approximately 292 mm. A cable is attached to the top.</p>	 <p>Technical drawing showing the front view of the SCD-310- Ex sensor head. It features a 1" BSP connection, a height of approximately 118 mm, and a diameter of approximately 294 mm. A cable is attached to the top.</p>	 <p>Technical drawing showing the front view of the SCD-330- / SCD-340- sensor head. It features a 1" BSP connection, a height of 106.0 mm, and a diameter of approximately 148 mm. A cable is attached to the top.</p>	 <p>Technical drawing showing the front view of the SCD-330- Ex / SCD-340- Ex sensor head. It features a 1" BSP connection, a height of 106 mm, and a diameter of approximately 145.5 mm. A cable is attached to the top.</p>	
	SCD-31J- __ SCD-31J- __ Ex		SCD-33J- __ SCD-33J- __ Ex SCD-34J- __ SCD-34J- __ Ex	
 <p>Technical drawing showing the top view of the Ball-joint Housing. The drawing is labeled "nivalco" and shows a circular housing with a diameter of $\phi 125$. A 1" BSP connection is visible on the left side.</p> <p>Ball-joint Housing (view from above)</p>	 <p>Technical drawing showing the side view of the SCD-31J- sensor assembly. The total height is approximately 765 mm, and the length of the sensor arm is approximately 150 mm. The base has a diameter of $\phi 292$ and a maximum tilt angle of $\text{max. } 20^\circ$.</p>		 <p>Technical drawing showing the side view of the SCD-33J- / SCD-34J- sensor assembly. The total height is approximately 725 mm, and the length of the sensor arm is approximately 140 mm. The base has a diameter of $\phi 148$ and a maximum tilt angle of $\text{max. } 20^\circ$.</p>	

3. INSTALLATION

POSITIONING

Selecting optimal location for the transmitter various considerations should be made.

If the measured material is granule (material size > 5 mm) and the tank roof is dome shaped or conical, do not install the transmitter in the centre of the tank/silo. In general the transmitter can be installed on the radius $r = (0,3 \dots 0,5) R$.

Avoid that the 5° conical beam angle of the transmitter contact the tank/silo wall. In case the transmitter is mounted close to the wall, it should be tilted (See section "Aiming"). Protect the transmitter electronics from overheating due to direct sunshine. The same way no disturbing objects such as ladder, grid, thermometer, etc should intrude into the beam cone. Heavy air movement can make measurement more difficult or even unable. Device should be protected against direct sunshine no to let its temperature increase into excessive range.

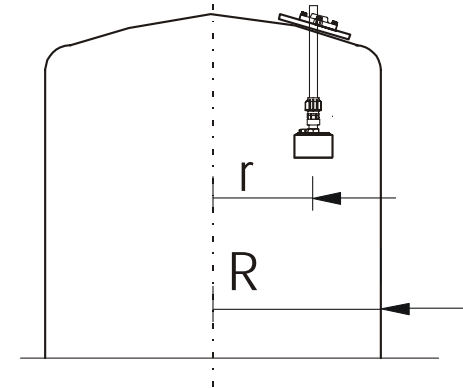

GRAVITY FILLING

Select a location that is as far away from the filling point(s) as possible.

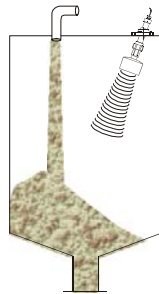

PNEUMATIC FILLING

Select a location where the speed of the in-flowing material is the smallest.

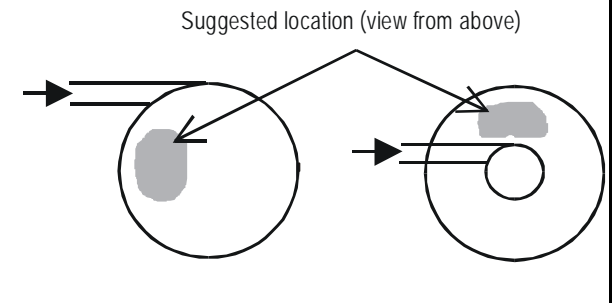

MOUNTING (see illustration of mounting options on the next page)

The EasyTREK consists of a sensor that is attached to the aiming arm (a pipe with a ball-joint housing incorporating a ball joint) that is attached to the housing of the electronics. It is recommended to mount the transmitter on the roof of the tank/silo using a flange (see drawing above). The Ball-joint housing has a screw-hole diameter of 125 mm for fixing it. For easy installation we recommend using our special flange with a split insertion, available in four sizes of DN125/150/200/300 (to be ordered separately). Removing the split insertion, the flange is to be put around the aiming arm and the ball-joint housing is to be fixed to the split flange. It is essential to use the washers and the bolts (4 pcs each) delivered with the split flange. The ball-joint will be pressed to the housing by a spring allowing adjustment/aiming. The 4 pcs of M12 bolts have to be tightened only after completing the adjustments/aiming.

When the entire tilting range of the aiming arm is required, the thickness of the roof can not exceed the values specified below.

The EasyTREK can also be mounted on existing (manhole) covers, access lids or for instance on a steel structure lowered into a larger (ex.: 0.5 x 0.5 m) opening on the roof. This solution is to be used with roofs thicker than 350 ... 380 mm.

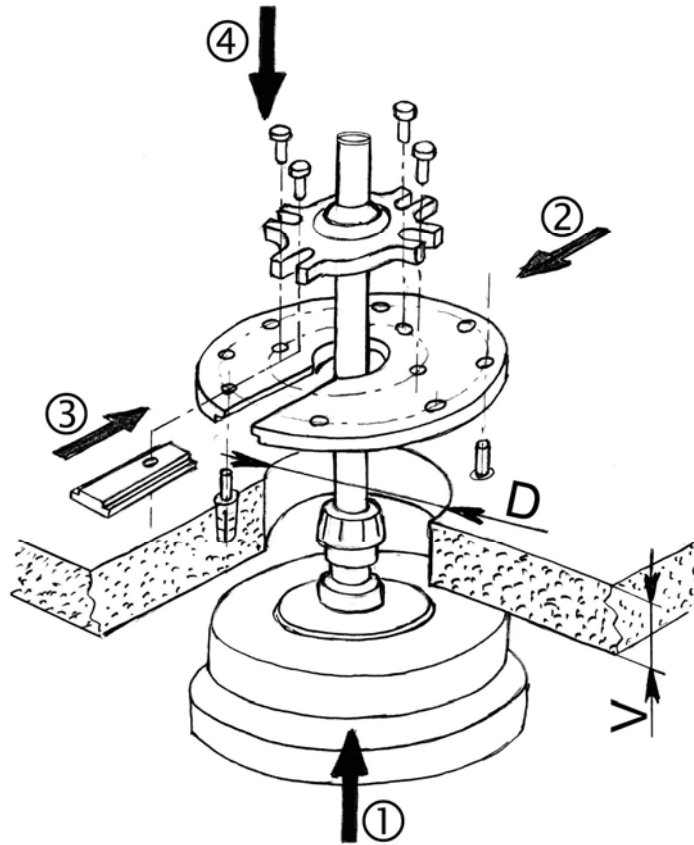

Illustration of mounting

Diameter of the Opening D	Maximum Thickness of the Roof V
160 mm	110 mm
190 mm	150 mm
230 mm	200 mm
300 mm	280 mm
340 mm	300 mm

4. WIRING

4.1. WIRING CONDITIONS

- The transmitter is SELV supplied. In the case of DC supply the connection is independent of polarity.
- Only SELV circuits can be switched on to the relay output.
- The house must be grounded to have noise protection; it should be grounded to the equipotential bonding net.
- 3-wire DC powered devices can be created by connecting one of the power supply wires to the white wire of the current output (GND). In this case the current output becomes galvanically non-isolated.
- The units and the cables should be arranged so that the fastening outside the device relieves the end of the cable of any traction.

4.2. CONNECTION CABLE EXTENSION

- It is advised to use a terminal box when cable extension is necessary. The shielding should be connected to the shielding of the extension cable and it should be grounded at the processing unit.

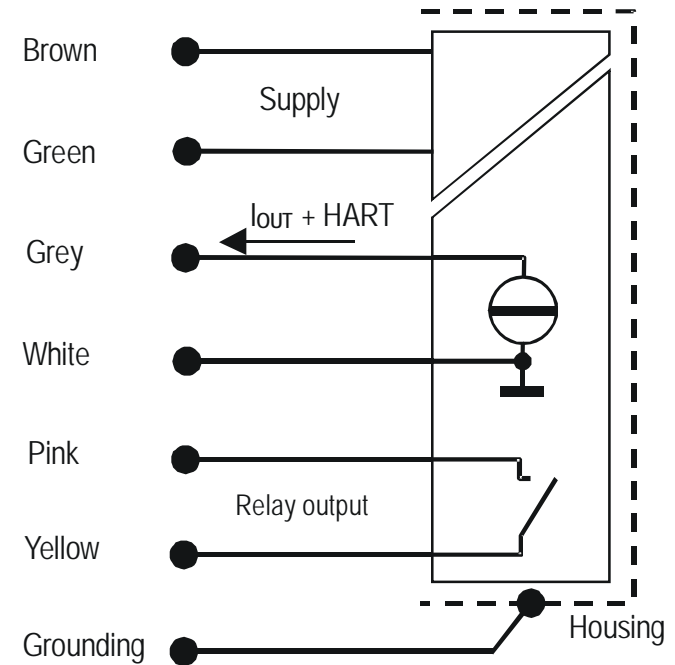

Colour codes of the outputs

Multiple SCD-300 transmitters connected to a MultiCONT process control unit

Power is supplied from a common external source, the relays are not used.

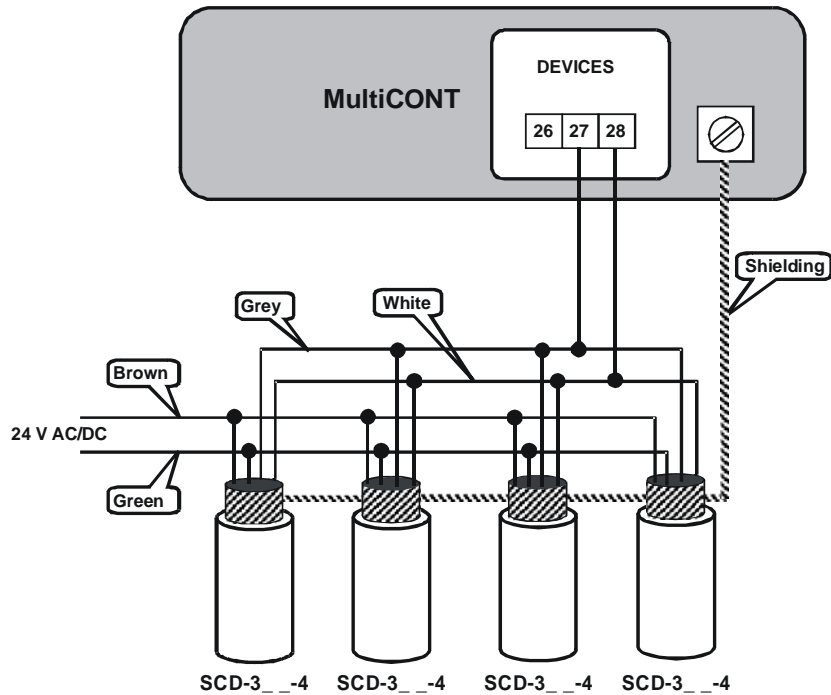

Trial and laboratory programming of the SCD-300 transmitters

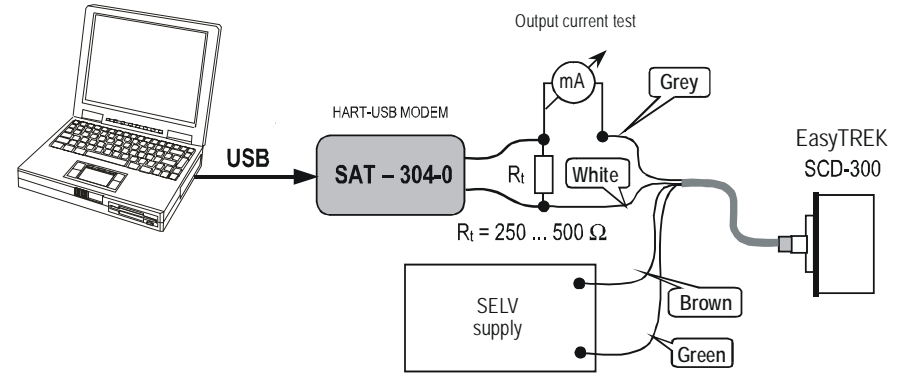

HART communication and power supply of one SCD-300 transmitter from the MultiCONT process control unit.

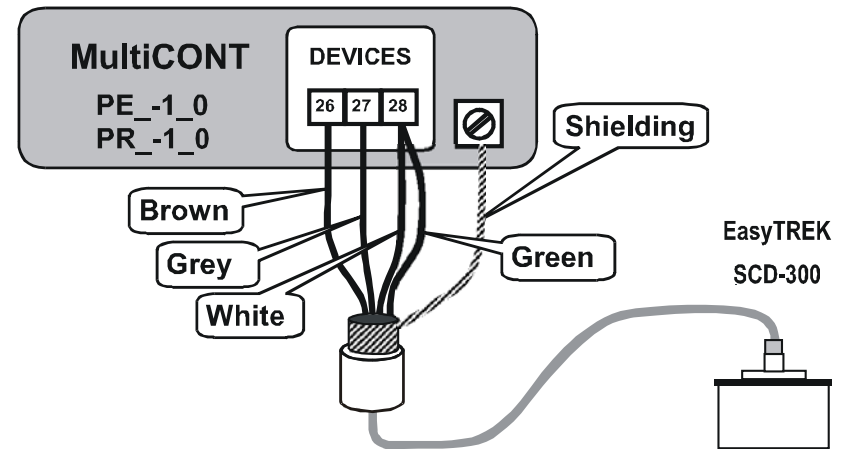

5. PUTTING INTO OPERATION, ADJUSTING, PROGRAMMING

5.1. PUTTING INTO OPERATION

After switching on the correctly wired unit the transducer begins to click audibly. In about 20 ... 50 s the ECHO LED goes on and a signal between 4 ... 20 mA appears on the current output. When first powering the unit, it measures with the standard manufacturer's settings (see some of the most important parameters below).

Default parameters

All the transducers get the same factory default parameters that can also be reset later if needed. Some of the most important parameters of the EasyTREK SCD-300 series can be found below.

- ⇒ Measurement mode: level (LEV),
- ⇒ 4 mA is assigned to the X_M maximum measuring distance (minimum level)
- ⇒ 20 mA is assigned to the X_m minimum measuring distance (maximum level)
- ⇒ Current output holds last value in case of error
- ⇒ Damping: 300 s

All the other measurement values are set to fit the values suitable for standard tasks. The functions used in special cases are switched off.

AIMING THE SENSORS

When the material to be measured is being filled or emptied, because of the formation of an angle of repose, the vertically installed transmitter will experience a weak signal. This can be eliminated in most cases by tilting the unit, so the aiming device is a very important part of these transmitters. The proper aiming can be set and checked while the transmitter is being used, desirably when the silo / tank is almost empty. Usually it is best that the transmitter points to the middle of the bottom of the silo/tank.

In cases when the silo is narrow, and the height / diameter value equals to or is more than 5, tilting is usually not necessary. Aiming should also be checked when the silo / tank is full, because the echo can be adversely weak even when coming from a nearby surface. This usually happens when the angle of repose is big. In this case an optimal solution must be found in which the echo coming from any distance is acceptable. The SERVICE PARAMETERS that can be reached during programming provide help for set-up. That means that the aiming adjustment and the programming should be done at the same time.

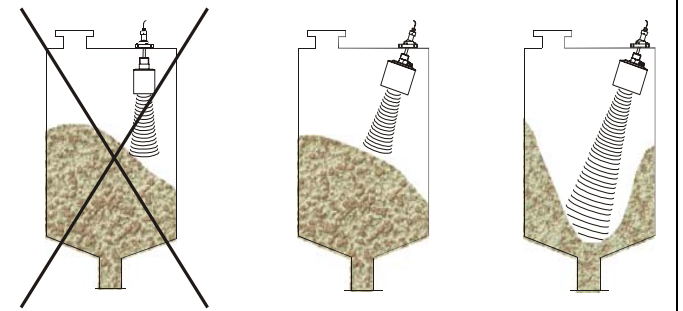

5.1.1. STATUS INDICATION SIGNALS IN MEASURING MODE

HART respond signals

The properly installed device with factory default settings gives the following responses to the COM3 universal HART command:

primary value	Level	
secondary value	Level	
tertiary value	Distance	
quaternary value	Temperature	(See P01 programming).

LED status signals on the unit

Green LED	COM	Lights up during HART programming.
Red LED	ECHO	Lights up when the device gets proper echoes.

5.2. SAFETY REGULATIONS OF THE EX APPROVED UNITS

Ex certified devices are approved for Zone 20 and Zone 21 areas.
Transmitters must not be installed in the dust path of the pneumatic filling!
Neither the device, nor any part of it should be used as a flame-proof barrier of a Zone 20 area.
The cable outside the unit should be fixed so that it is tension-free.
The terminal box should be selected in accordance with the electrical class of the area.

5.3. PROGRAMMING

HART interface of the EasyTREK enables full access and programming of the complete parameter set.

Parameters can be accessed by two ways:

- with a HART modem and EView or Eview light configuration software run on a PC
- by the HiTECH/NIVELCO made MultiCONT multichannel controller

This instruction describes parameters and features behind them but does not deal with technical details for their selection and editing of their values. Compact Disk attached to the transmitter contains detailed information on the Eview configuration software (to install on PC) and its description. Programming by the MultiCONT can be taken from its Installation and Programming Manual.

Continuous measuring is going on during programming in accordance with the last programmed parameter set. This way the analog output signal (4-20mA) continuously represents the actual value. The digital (HART) communication depends on the communication software. The new, modified parameter set will be valid after returning to measurement mode. The device changes back to measurement mode automatically in 1 minute after programming through HART communication has been finished or discontinued.

5.4. PARAMETERS – DESCRIPTION AND PROGRAMMING

5.4.1. MEASUREMENT CONFIGURATION

P00: - c b a Application/Engineering Units

ATTENTION!
Programming of this parameter will result in loading the factory default with the corresponding engineering units.

a	Operating (measurement) mode	
1	Free flowing solids level measurement	

b	Engineering units (according to "c") (according to „c“)	
	Metric	US
0	m	ft
1	cm	inch

c	Calculation system
0	Metric
1	US

FACTORY DEFAULT: 001

DEVICE CAN BE OPERATED WITH TWO DIFFERENT ENGINEERING UNIT SYSTEMS, BUT FOR THE SAKE OF EASY OVERVIEW ONLY THE METRIC SYSTEM WILL BE USED!

P01: - - b a Measurement Mode

Values transmitted by HART protocol, current output and the switching points of the relays will be interpreted into the engineering units of the (measured or calculated) process value corresponding to the programmed measurement mode. On the other hand, the higher the "a" of the programmed parameter value the more (measured or calculated) process values can be transmitted through HART (e.g. if P01=0 only the Distance, if P01=4 Distance, Level and Volume; Exception: P01=2 or 4.)

a	MEASUREMENT MODE	TRANSMITTED PROCESS VARIABLES	PRIMARY VARIABLES TRANSMITTED THROUGH HART	OTHER VARIABLES TRANSMITTED THROUGH HART
0	Distance	Distance	DIST	Secondary: LEV Tertiary: DIST Quaternary: Temp
1	Level	Level	LEV	
2	Level in percent		LEV%	
3	Volume	Volume	VOL	
4	Volume in percent		VOL%	

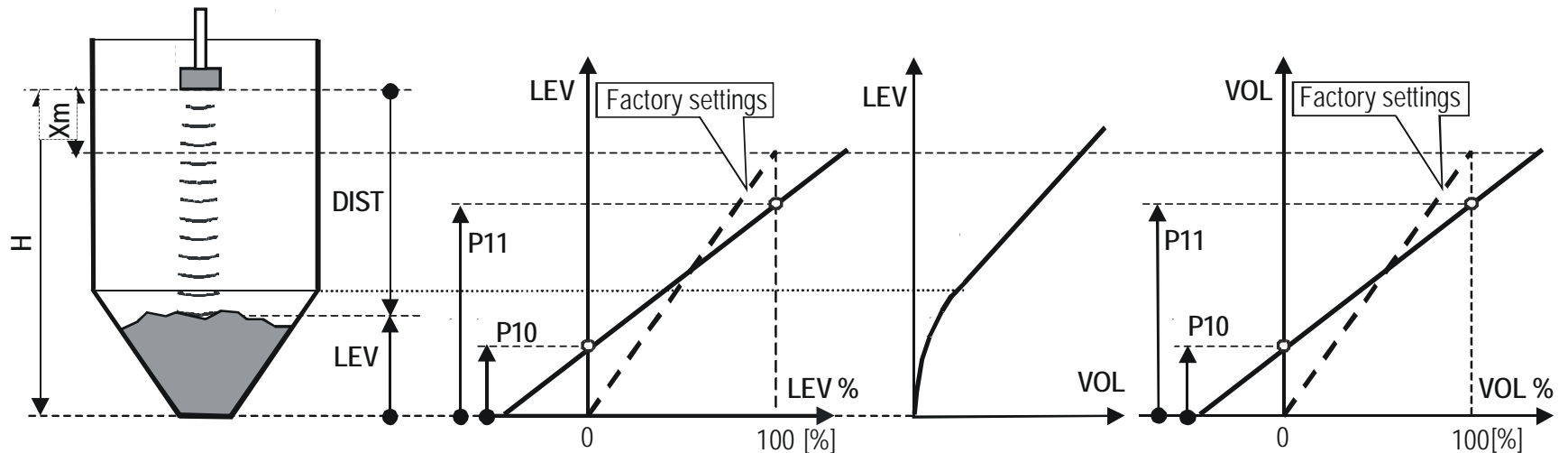

P02: - c b a Calculation units

a	Temperature
0	°C
1	°F

This table is interpreted according to P00(c), P01(a) and P02(c) and is irrelevant in case of percentage measurement (P01(a)= 2 or 4)

b	Volume		Weight (set also P32)	
	Metric	US	Metric	US
0	m ³	ft ³	tone	lb (pound)
1	litre	gallon	tonne	tonne

c	The value of character c has no significance at devices for solids
---	--

FACTORY DEFAULT: 000

P03: - - - a Values displayed – Rounding (Not used at EasyTREK)

P04: - - - - Maximum measuring distance (H and X_M)

Maximum measuring distance is the greatest distance (**H**) between the sensor surface and the farthest surface to be measured in the application. Factory default of this parameter is the **maximum distance (X_M) that can be measured** by the unit. (See table below) During programming **P04** should be set for the **maximum distance (H) to be measured**, whereas $H \leq X_M$.

EasyTREK Level transmitters for liquids	Maximum measuring distance (X _M) [m]
S□D – 34□ – □	15
S□D – 33□ – □	30
S□D – 31□ – □	60

Keep in mind that **LEVEL** (as the result of the measurement) = **P04** (programmed) – **DISTANCE** (measured by the device)

Since the accuracy of level (and all further calculated) value depends on the accuracy of the max measuring distance of the application which is the distance between the sensor face and the tank / silo bottom.

To obtain the best accuracy for liquid level measurement, measure with EasyTREK this distance in the empty tank.

FACTORY DEFAULT: distance of X_M as per table above

P05: - - - - Minimum measuring distance (Close-end blocking)

Basic feature of the ultrasound level meters is their not being able to measure next to the sensor surface. Within this range the measurement can not be interpreted, thus it should be avoided that material level get into this range. By entering a value, higher than the factory default, the minimum measuring range will be extended and fixed to that value. Manual close-end-blocking would be used for example to block out the echo originating from the bottom rim of a stand-off pipe or from any object protruding into the ultrasonic cone near to the transmitter.

Automatic Close-end-blocking (Automatic Dead Band control)

By using the factory default value, the unit will automatically be adjusted to the smallest possible dead band (X_m). In ideal cases this can be smaller and in disadvantageous mountings greater than the dead band.

Manual close-end-blocking $P05 = X_B > X_m$

Entering greater value in P05 than X_m will represent the extension of the close end blocking.

EASYTREK Level transmitters for liquids	Minimum measuring distance (X_m) [m]
S□D - 34□ - □	0,5
S□D - 33□ - □	0,6
S□D - 31□ - □	1,0

FACTORY DEFAULT: automatic close end blocking (X_m as per the table)

P06: - - - - Far-end blocking

Far-end blocking is the range below the level set in parameter **P06**. Far-end blocking can be used to avoid disturbing effects of stirrers or heaters at the bottom of the tanks.

When the unit detects echoes in this range it gives special signals.

When level sinks below far-end blocking:

- Message of "Sub 0" appears in EView (in level and volume measurement mode)
- Current output holds value corresponding to far-end blocking distance

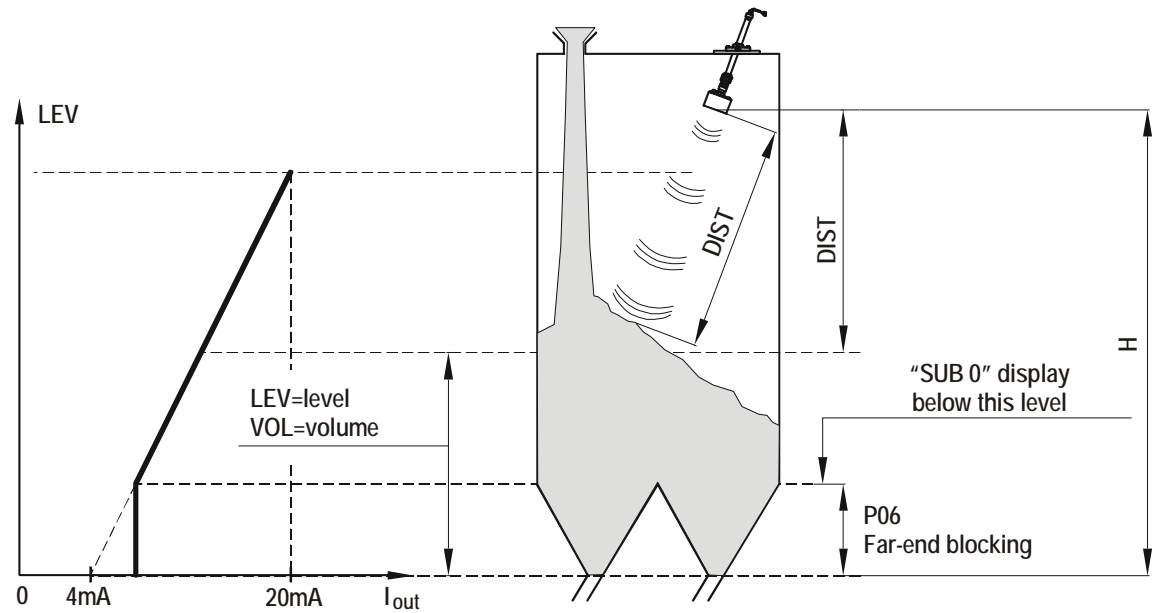

When level rises above far-end blocking:

The calculation of level and volume will be based on the programmed tank dimensions, therefore the measured or calculated process values will not be influenced in any way, by the value of far-end blocking.

FACTORY DEFAULT: 0

5.4.2. CURRENT VALUE

P08: - - - Fixed output current

With this step the output current can be set as a fix value, selected between 3,8 mA and 20,5 mA. This function is not operational as per the factory default: 0. **Attention: fixing output current will make settings in P10, P11, P12 and P19 irrelevant.**

FACTORY DEFAULT: 0

P10: - - - Value (of distance, level or volume) assigned to 4 mA current output

P11: - - - Value (of distance, level or volume) assigned to 20 mA current output

Values are interpreted according to P01(a). Please note that in case of programming for (LEV or VOL) % measurement the min and max value has to be entered in the relevant engineering units of LEV (m, ft) or VOL (m³, ft³).

Assignments can be made so that the proportion between the change of the (measured or calculated) process value and the change of the current output be either direct or inverse. E.g. lev 1m assigned to 4mA and lev 10m assigned to 20mA represents direct proportion and lev 1m assigned to 20mA and lev 10 m assigned to 4mA represents inverse proportion.

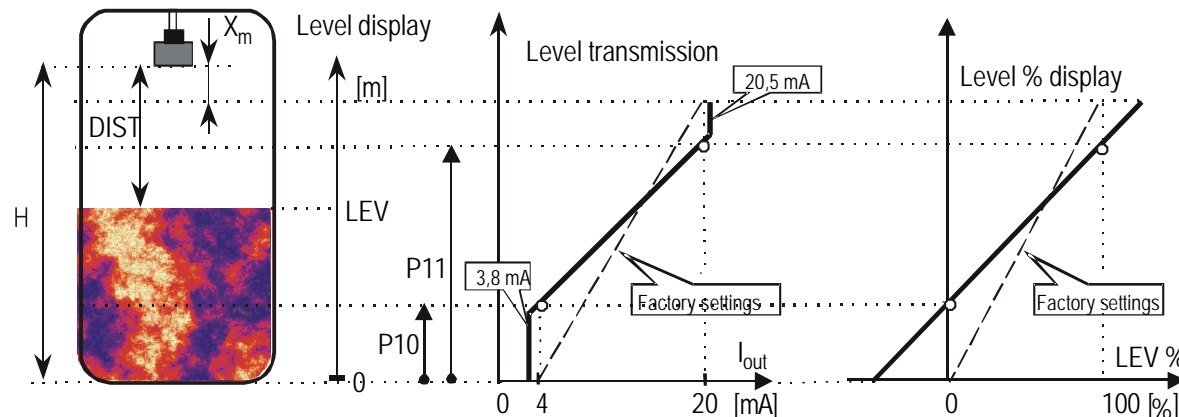

FACTORY DEFAULT: P10: 0, P11: X_M - X_m .(See P04 and P05)

P12: - - - a Error indication by the current output

In case of error the EasyTREK will provide one of the current outputs below for the time the failure prevails.

a	Error indication (according to NAMUR)
0	HOLD last value
1	3,6 mA
2	22 mA

FACTORY DEFAULT: 0

5.4.3. RELAY OUTPUT

P13: - - - - Relay functions

a	Relay functions		Also to set:
0	DIFFERENTIAL LEVEL CONTROL (Hysteresis control)	If the value selected for controlling the relay increases over P14 : relay energises decreases below P15 : relay de- energises	P14, P15 Keep at least 2 cm difference between P14 and P15
1	ERROR INDICATION	"no ECHO" indicated by energised relay	—
2		"no ECHO" indicated by de-energised relay	—

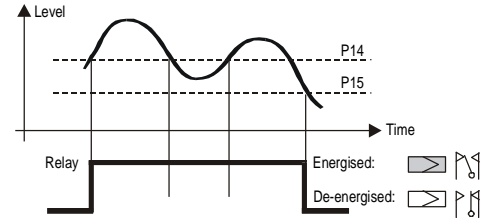

FACTORY DEFAULT: 2

P14: ... Relay parameter – Setpoint value

FACTORY DEFAULT: 0

P15: - - - - Relay parameter – Setpoint value

Relay set points are to be programmed for two-point control. Values should be set in the quantity selected for transmitting in parameter **P01**. Keep at least 20 mm difference between P14 and P15

FACTORY DEFAULT: 0

P19: - - - - HART short address

Short address is to enter here. The 00 short address is suitable for loop with one device only, when both analogue signal and HART is able to carry information. For other settings see instruction in the manual for the configuration software EView supplied with the unit.

FACTORY DEFAULT: **P19** = 00

5.4.4. MEASUREMENT OPTIMALIZATION

P20: - - - a Damping

This parameter can be used for reduction of unwanted fluctuation of the displayed value and the output.

a	Damping time [s]	Granules particle size >2-3 mm	DUST particle size < 1-2 mm
0	None	For test only	
1	3	Not recommended	Not recommended
2	6	Not recommended	Not recommended
3	10	Not recommended	Not recommended
4	30	Applicable	Not recommended
5	60	Recommended	Applicable
6	100	Recommended	Recommended
7	300	Recommended	Recommended
8	600	Recommended	Recommended
9	1000	Applicable	Applicable

FACTORY DEFAULT: 7 (300 s)

P23: - - - a Angle of repose (repose formation)

This parameter is important for the optimisation of the of the QUEST⁺ software echo evaluation.

a	Estimated angle of repose
0	No angle of repose $\alpha \cong 0$
1	$\alpha < 15^\circ$
2	$\alpha > 15^\circ$

The optimal setting of this parameter can be done with the help of checking the echo strength in the read out parameter **P72** indicating the echo amplitude in dB.

The ideal setting of **P23** is at which the parameter value in **P72** becomes the best (nearest "0").

FACTORY DEFAULT: 0

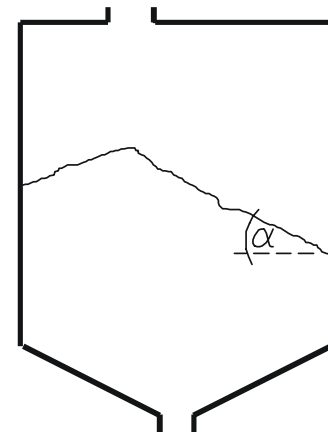

P24: - - - a Target tracking speed

With this parameter the evaluation can be sped up at the expense of the accuracy.

a	Tracking speed	Remark
0	Standard	For most applications
1	Fast	For fast changing level
2	Special	For very special cases only, as this reduces the maximum measuring range to 50% of the nominal value! The measuring window (P25 and P33) is inactive and the EasyTREK will respond practically instantly to any target.

FACTORY DEFAULT: 0

P25: - - - a Selection of Echo within the measuring window

A so-called measuring window is formed around the echo signal. The position of this measuring window determines the flight time for calculation of the distance of the target. (the picture below can be seen on the test oscilloscope)

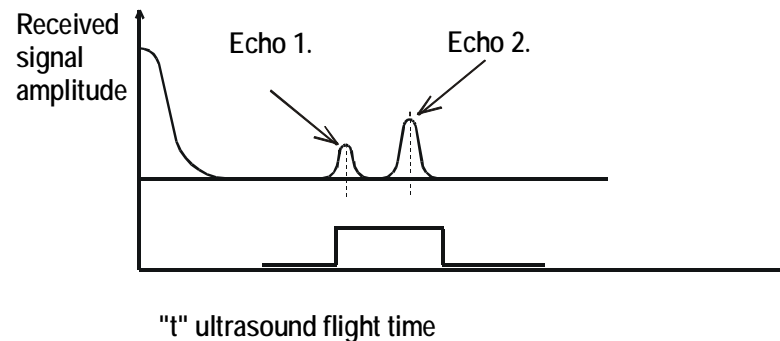

Some applications involve multiple (target + disturbing) echoes even within the measuring window. Basic echo selection will be done by the Quest + software automatically. This parameter only influences the echo selection within the measuring window.

a	Echo in the window to be selected	Remarks
0	With the highest amplitude	For most applications (both liquids and solids)
1	First one	For applications with multiple echoes within the Measuring Window
2	Largest one	Recommended for applications with floating material in the air

FACTORY DEFAULT: 0

P26: - - - Level elevation rate (filling speed) [m/h]

FACTORY DEFAULT: 500

P27: - - - - Level wane rate (emptying speed) [m/h]

Use these parameters to provide additional protection against echo loss in applications involving dust during the filling process (powders, dusting granules). Reliability of the measurement can be enhanced by the correct setting of this parameter.

These parameters must not be smaller than the fastest possible filling/emptying rate of the actual technology.

FACTORY DEFAULT: 500

P28 - - - a Echo-loss handling

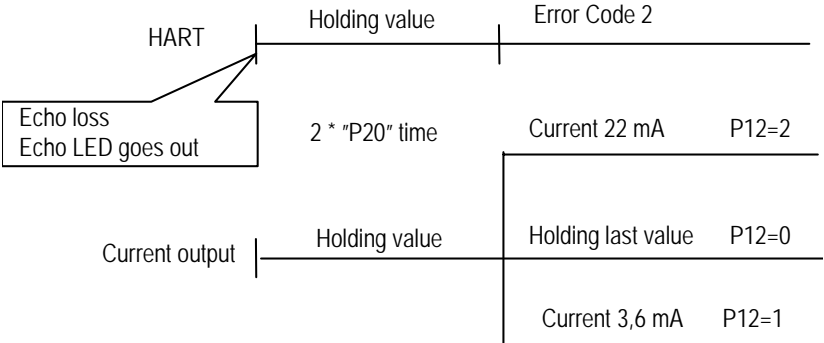
a	Echo-loss error indication	Remark
0	Delayed	<p>During short periods of echo-loss, both EView and the analogue output will hold last value. The current output holds last value for twice as long as set in P20 before going to the "Error Indication Mode" set in P12.</p> 
1	None	During an echo-loss the displayed value on the EView and the analogue output value will hold last value.
2	Advance to full	When echo-loss occurs during filling, the displayed value on the EView and the analogue output value shifts towards the "full" tank/silo state with the level elevation rate (filling speed) set in P26
3	Immediate	In case of an echo-loss, 'no Echo' will appear in EView and the outputs will change according to the "Error Indication Mode" set in P12.
4	No echo-loss indication in case of empty tank/silo	Echo-loss may occur in completely empty tanks with a spherical bottom due to deflection of the ultrasonic beam, or in case of silos with an open outlet. If the echo is lost when the tank/silo is completely empty, the indication will correspond to empty tank, in all other cases echo-loss indication will function according to the "Delayed".

FACTORY DEFAULT: 0

P29 Blocking out of object

One object in the tank/silo disturbing measurement can be blocked out.
Enter distance of the object from the transducer. Use the Echo Map (P70) to read out the precise distance of disturbing objects.
FACTORY DEFAULT: 0

P31: Sound velocity at 20°C (m/sec or ft/sec depending on P00(c))

Use this parameter if the sound velocity in the gases above the measured surface differs largely from that of in air.
Recommended for applications where the gas is more or less homogeneous. If it is not, the accuracy of the measurement can be improved using the 32-point linearization (P48, P49).

For sound velocities in various gases see section "Sound Velocities".

FACTORY DEFAULT: Metric (P00: "EU"): 343.8 m/s, US (P00: "US"): 1128 ft/s

P32: Specific gravity

If you enter value (other than "0") of specific gravity in this parameter, the weight will be displayed in EView instead of VOL.
FACTORY DEFAULT: 0 [kg/dm³] or [lb/ft³] depending on P00(c)

P33: (m) Manual echo selection by moving the Measuring Window

A so-called measuring window is formed around the echo signal (See scheme on the next page.)
The distance of the target will be calculated from the flight time in accordance with the position of the measuring window.

Use this parameter if the EasyTREK unambiguously selects a wrong echo; for example the echo reflected from the surface is much weaker than the interfering one(s) (see figure beside and on next page).

Enter the *distance* of the correct echo and the software will move the measuring window and calibrate itself to the echo found there.

To determine the distance of the correct echo, either use the Echo Map (to load-in a value from the Echo Map, see parameter P70), or measure the distance with an appropriate device, and enter this value in P33.

If this parameter has been used (P33 is not 0), its value will be continuously updated with the valid echo position.
This means, that in case of a power loss, the EasyTREK will restart the signal processing with the measuring window at the last updated position. To switch-off this function, set P33= 0.

FACTORY DEFAULT: 0

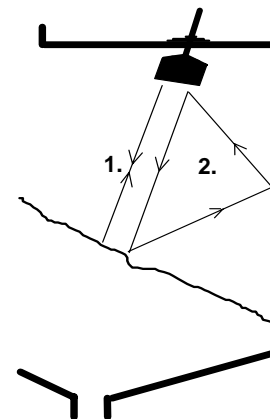

MANUAL ECHO SELECTION

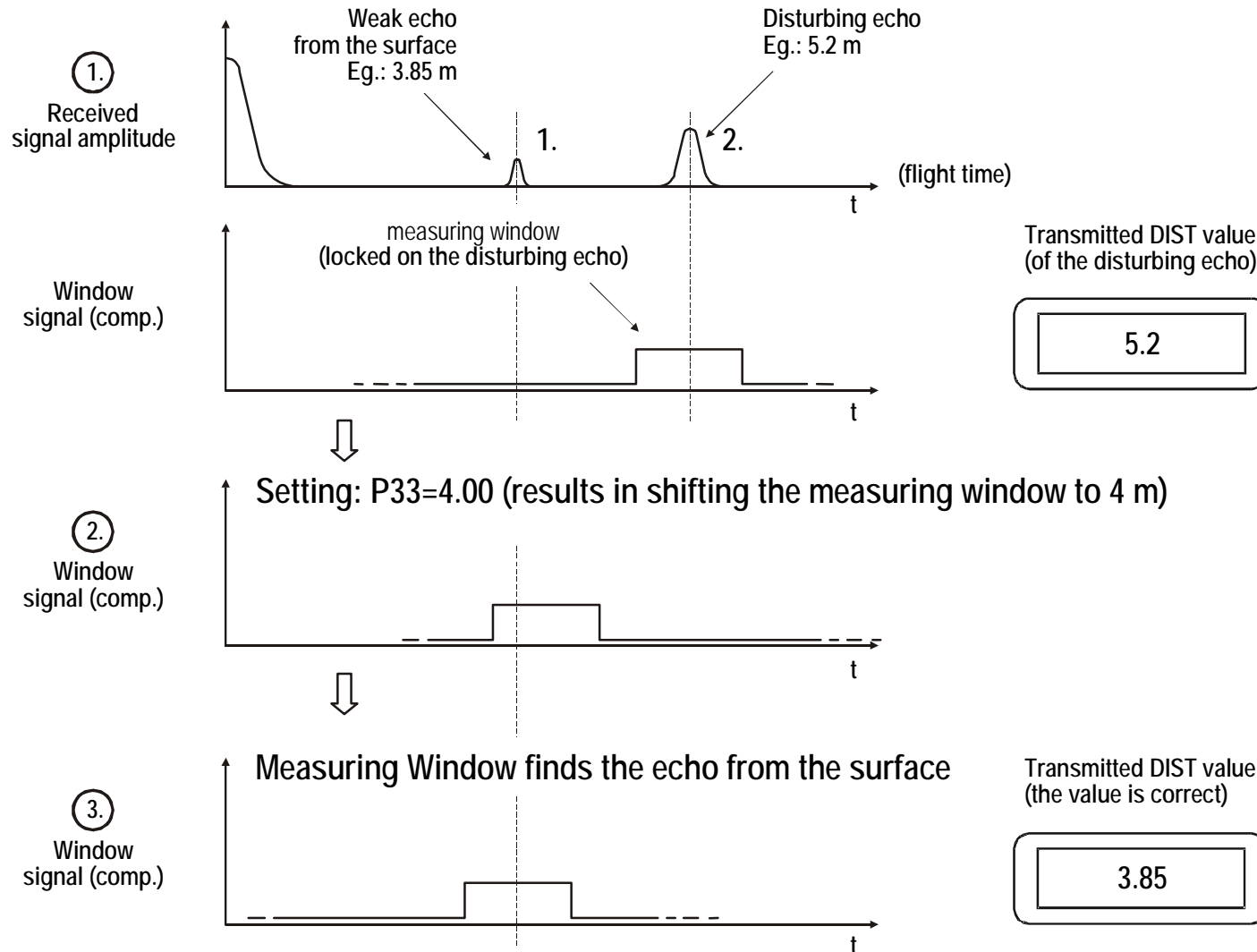

5.4.5. VOLUME MEASUREMENT

P40: - - ba Tank / silo shape

ba	Tank/silo shape	Other parameters to be set
B0	Standing cylindrical tank shape: value of "b" as below bottom	P40(b), P41
01	Standing cylindrical tank/silo with conical bottom	P41, P43, P44
02	Standing rectangular tank/silo (with chute)	P41, P42, P43, P44, P45
B3	Lying cylindrical tank shape: value of "b" as below bottom	P40(b), P41, P42
04	Spherical tank	P41

FACTORY DEFAULT: 00

P41-45: - - - Tank / silo dimensions

Standing cylindrical tank/silo with hemispherical bottom

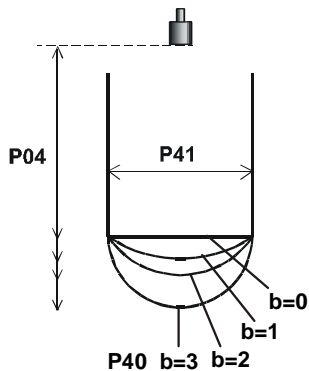

Standing cylindrical tank/silo with conical bottom

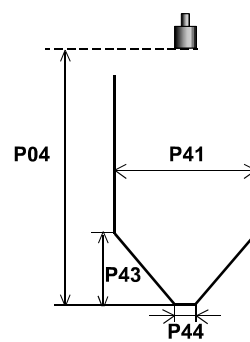

Standing rectangular tank/silo with or without chute

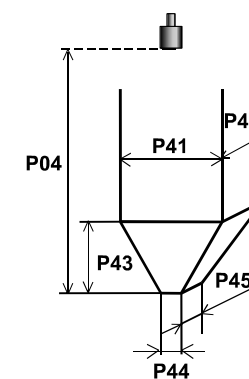

Lying cylindrical tank

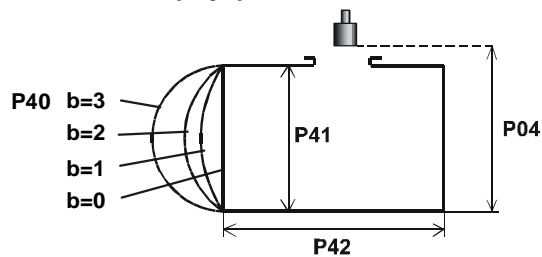

Spherical tank

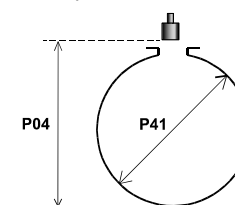

For flat bottom
P43, P44 and
P45 = 0

FACTORY DEFAULT: P41 ... P45 = 0

5.4.6. LINEARIZATION

P47: --- a Linearization

Linearization is the method of assigning requested (calibrated or calculated) level, volume or flow to values measured by the transmitter.

It can be used for instance if the sound velocity is not known (LEVEL \Rightarrow LEVEL) or in the case of tank with other shape than under 5.4. 5. (LEVEL \Rightarrow VOLUME).

a	Linearization
0	OFF (FACTORY DEFAULT)
1	ON

Conditions of correct programming of the data pairs

The table must always start with: L(1)= 0 and r(1)= value (assigned to 0 level)

The table must be ended either with the 32nd data pair i.e. j=32 or if the linearisation table contains less than 32 data-pairs j<32, it must be ended with a level value "0" e.g. L(j<32)= 0.

The EasyTREK will ignore data after recognising level value "0" with serial number other than "1".

If the above conditions are not met, error codes will be sent (see chapter: Error Codes).

i	L (Left column) Level values measured	r (Right column) Value assigned to transmit
1	0	r(1)
2	L(2)	r(2)
	L(i)	r(i)
nn	L(nn)	r(nn)
nn+1	0	
32		

FACTORY DEFAULT: 0

P48: Number of linearization data pairs

Number of linearization data pairs entered in the table.

5.4.7. INFORMATIONAL PARAMETERS

P60: - - - - Overall operating hours of the unit (h)

P61: - - - - Time elapsed since last switch-on (h)

P62: - - - - Operating hours of the relay (h)

P63: - - - - Number of switching cycles of the relay (h)

P64: - - - - Actual temperature of the transducer (°C/°F)

Broken loop of the thermometer will be indicated by Pt Error message that is initiated by a signal sent via HART. In this case the transmitter will perform temperature correction corresponding to 20°C.

P65: - - - - Maximum temperature of the transducer (°C/°F)

P66: - - - - Minimum temperature of the transducer (°C/°F)

P70: - - - - Number of Echoes / Echo Map

Amplitude and position of the echoes can also be read out.

- P71: - - - - Distance of the of Measuring Window
- P72 - - - - Amplitude of the selected echo [dB] <0
- P73: Position of the selected echo (time) : (ms)[ms]
- P74: Signal to Noise Ratio

Ratio	Measurement conditions
Over 70	Excellent
Between 70 and 50	Good
Under 50	Unreliable

P75: - - - - Blocking Distance

This parameter gives information about the actual close-end blocking distance (provided automatic blocking was selected in **P05**)

5.4.8. TEST PARAMETERS

- P96: - - - - Checksum
- P97: - - - - Software code (Read only parameter)
- P98: - - - - Hardware code (Read only parameter)
- P99: dcba Access lock by secret code

The purpose of this feature is to provide protection against accidental programming of parameters or by a person. not entitled. The secret code can be any value other than **0000**. Setting a secret code will automatically be activated when the EasyTREK is returned to the Measurement Mode. In order to program locked device the secret code should be entered first in **P99**. Thus for entering a new code or erasing the old one the knowledge of the previous code is necessary.

5.4.9. ERROR CODES

Error Code	Error description	Causes and actions to be done
1	Memory error	Contact local agent
No Echo or Err2	Echo loss or echo too weak to evaluate	Bad reflection from the surface, reflection not directed towards the sensor, due to dusting excessive sound absorption. Check device selection and/or adjustment
Err3	Hardware error	Contact local agent
Err4	Calculation overflow	Check settings
Err5	Code referring to sensor error or improper installation/mounting, level in the dead band	Verify sensor for correct operation and check for correct mounting according to Users Manual
Err6	The measurement is at the reliability threshold	Change aiming or try to find a better location
Err7	No signal received within the measuring range specified in P04 and P05.	Review programming, also look for installation mistake
Err12	Linearization table error: L(1) and L(2) are both zero (no valid data-pairs)	See the Section "Linearization"
Err13	Linearization table error: there are two same L(i) data in the table	See the Section "Linearization"
Err14	Linearization table error: the r(i) values are not monotone increasing	See the Section "Linearization"
Err15	Linearization table error: measured Level is higher than the last Volume or Flow data-pair	See the Section "Linearization"
Err16	The checksum of the program in the EEPROM is wrong	Contact HITECH at 888 NIVELCO

6. MAINTENANCE, REPAIR

The device does not require routine maintenance. In case dust adheres to the face of the sensor despite the self-cleaning of the sensor face through resonance, (ex.: static build-up) it can be cleaned by pressurised air.

Equipment sent back for repair should be cleaned or sterilised by the User. The User must declare that the above has been carried out.

Repairs during or beyond the guarantee period are carried out by HiTECH/NIVELCO.

7. STORAGE CONDITIONS

Environmental temperature range: - 22°F (-30) ... 140°F (+60°C)

Relative humidity: max. 98 %

8. Parameter TABLE

Par.	Page	Description	Value				Par.	Page	Description	Value			
			d	c	b	a				d	c	b	a
P00	16	Application/Engineering Units					P28	25	Echo loss indication				
P01	17	Measurement Mode					P29	26	Blocking out of disturbing object				
P02	18	Calculation units					P30		-				
P03		-					P31	26	Sound velocity in different gases				
P04	18	Maximum Measuring Distance					P32	26	Specific gravity				
P05	19	Minimum Measuring Distance					P33		-				
P06	20	Far End Blocking					P34		-				
P07		-					P35		-				
P08		-					P36		-				
P09		-					P37		-				
P10	21	Transmitted value assigned to „4 mA“					P38		-				
P11	21	Transmitted value assigned to „20 mA“					P39		-				
P12	21	“Error” indication by the current output					P40	28	Selection of tank shape/ open channel				
P13		-					P41	28	Dimensions of tank / Open Channel				
P14		-					P42	28	Dimensions of tank / Open Channel				
P15		-					P43	28	Dimensions of tank / Open Channel				
P16		-					P44	28	Dimensions of tank / Open Channel				
P17		-					P45	28	Dimensions of tank / Open Channel				
P18		-					P46		Level pertaining to flow Q= 0				
P19		-					P47	29	Linearization				
P20	23	Damping					P48	29	Linearization table				
P21		-					P49		-				
P23		-					P50		-				
P24	24	Target tracking speed					P51		-				
P25	24	Selection of Echo in the measuring window					P52		-				
P26	24	Level elevation rate					P53		-				
P27	25	Level descent rate					P54		-				
							P55		-				

Par.	Page	Description	Value			
			d	c	b	a
P56	-					
P57	-					
P58	-					
P59	-					
P60	30	Overall operating hours of the unit				
P61	30	Time elapsed after last switch-on				
P62	-					
P63	-					
P64	30	Actual temperature of the transducer				
P65	30	Maximum temperature of the transducer				
P66	30	Minimum temperature of the transducer				
P67	-					
P68	-					
P69	-					
P70	30	Echo Map				
P71	31	Position of the measuring window				
P72	31	Amplitude of the selected echo				
P73	31	Position of the selected echo				
P74	31	Signal / noise ratio				
P75	33	Blocking distance value				
P76	34	Water head of the flow				
P77	34	TOT1 volume flow totalised				

Par.	Page	Description	Value			
			d	c	b	a
P78	34	TOT2 volume flow totalised				
P79	-					
P80	-					
P81	-					
P82	-					
P83	-					
P84	-					
P85	-					
P86	-					
P87	-					
P88	-					
P89	-					
P90	-					
P91	-					
P92	-					
P93	-					
P94	-					
P95	-					
P96	34	Software code 1				
P97	34	Software code 2				
P98	34	Hardware code				
P99	34	Access lock by secret code				

scd3404a0600p_01.doc
May 2006

HiTECH/NIVELCO reserves the right to change technical specifications without notice.