

HiTECH
Technologies, Inc.

User Manual

MiniLASER

Version 1.3



CE

Dear Customer,

We strongly recommend that you carefully read this Manual before powering on the standard HiTECH MiniLASER or the HiTECH MiniLASER HiSPEED laser distance measuring systems for the first time.

This is an absolute requirement to ensure that you will be able to utilize all the MiniLASER's capabilities and features.

This technology is subject to continuously ongoing development.

Editorial deadline: May 2005

Manual version: V 1.3.2

Firmware version: from 3.07

Note:

Proper care has been used in compiling this document. No liability will be accepted in the event of damage resulting from failure to comply with the information contained herein.

Any question, please contact:

HiTECH Technologies, Inc.
301 Oxford Valley Road, Bldg 505
Yardley PA 19067-7111 USA
Website: www.hitechtech.com
Email: info@hitechtech.com

Tel: 215. 321. 6012

Fax: 215. 321. 6067

Content

1. General	5
2. Safety Instructions	7
2.1. Safety Instructions	7
2.2. Intended & Conforming Use	7
2.3. Nonconforming Use	7
2.4. Laser Classification	8
2.5. Electric Supply	9
2.6. Important Operating Advice	9
3. Technical Data	10
4. Mechanical Mounting Conditions	12
5. Assignments of Connector and Interface Cable	14
5.1. Connector Terminal	14
5.2. Interface Cable	15
5.3. Shield and Grounding	16
5.4. Termination of RS 232	17
6. Limiting Values for Voltages	18
7. Start up	19
8. Commands and Parameter	20
8.1. General	20
8.2. DT.....distancetracking	22
8.3. DW.....distancetracking with cooperative target (10Hz)	23
8.4. DX.....distancetracking with cooperative target (50Hz)	23
8.5. DF.....distance measurement with external trigger	23
8.6. DM.....distance measurement	23
8.7. TP.....internal temperature [°C]	24
8.8. SA.....display/set average value [1..20]	24
8.9. SD.....display/set display format [d/h]	24
8.10. ST.....display/set measure time [0..25]	24
8.11. SF.....display/set scale factor	25
8.12. SE.....display/set error mode [0/1/2]	26
8.13. AC.....display/set ALARM center	26
8.14. AH.....display/set ALARM hysteresis	26

8.15.	RB.....display/set distance of lout=4mA	27
8.16.	RE.....display/set distance of lout=20mA	27
8.17.	TD.....display/set trigger delay	27
8.18.	BR.....display/set baud rate [2400..38400]	27
8.19.	AS....display/set autostart command	28
8.20.	OF.....display/set distance offset	28
8.21.	SO.....set current distance to offset	28
8.22.	LO.....laser on	28
8.23.	LF.....laser off	28
8.24.	PA.....display settings	28
8.25.	PR.....reset settings	29
9.	Interface connection	29
9.1.	Serial Interface RS232.....	29
9.2.	Serial Interface RS422.....	29
9.3.	Digital Switching Output (Alarm).....	30
9.4.	Analog Output.....	31
9.5.	Trigger Input	32
10.	List of Commands	34
11.	Error Codes	35
12.	PC Interface Cable (Option).....	36
13.	Service and Warranty	37

1. General

The HiTECH MiniLASER is a laser range finder to measure distances from 0.1 m (4.0") to more than 100 m (328') with pinpoint accuracy.

A given target can be clearly identified with the help of a red laser sighting point. In terms of operating reach, the HiTECH MiniLASER performs depending on the reflectance, morphology and qualities of the target to be measured.

The range finder works based on comparative phase measurement. It emits a modulated high-frequency light which is diffusely reflected back from the target with a certain shift in phase to be compared with a reference signal. From the amount of phase shift, a required distance can then be determined with millimeter accuracy.

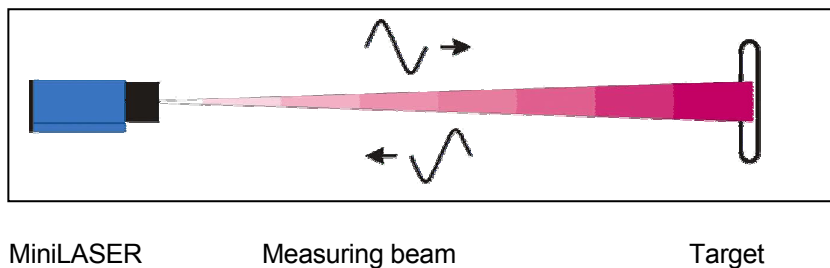

Figure 1 Measurement principle

A distance measuring cycle can be triggered in three different ways:

- By sending a command from a PC or another equivalent control unit
- By making appropriate prior parameter settings for the auto start command and applying supply voltage
- By external triggering (in remote-trigger mode).

For a more detailed description of these three trigger options, you should consult section chapter 8 of this User Manual.

Special performance features are:

- Provides high accuracy and great reach under extreme outdoor temperatures.
- Works in a wide range of operating voltages from 10 VDC to 30 VDC from an on-board vehicle supply point, an industrial direct voltage supply net or a DC power pack.
- Features consistently low power consumption of <1.5 W without alarm.
- Up to 100 feet (30 m) range for measurement, with a potential for more than 328 feet (100 m) range if additional reflectors¹ are mounted onto the target (depending on reflectance and environmental conditions).
- Visible laser beam point for easy sighting.
- RS232 interface port for input of measuring functions and commands from, and output of measured values to, a PC or a laptop.
- Switching output and analog output are separately programmed.
- Switching output with adjustable limit and hysteresis.
- Measured values can be displayed in meters, decimetres, centimetres, feet or inches.
- Option for remote triggering of a measurement from an external trigger device.

¹ e.g. 3M, self adhesive foil white non glossy

2. Safety Instructions

2.1. Safety Instructions

These safety and operating instructions should be carefully read and followed during practical work with the MiniLASER.



There is danger of laser radiation or electrical shock. For necessary repair work, the HiTECH MiniLASER may not be opened by anyone other than HiTECH certified MiniLASER technical service personnel. All warranties, guaranties as well as repair attempts by any non-certified personnel into the inner product space will void any warranty claims and prevent any possibility of future factory repairs.

Compliance with all specified operating conditions is necessary. Failure to observe advisory notes or information contained in this Manual or nonconforming product usage may cause physical injury to the user or material damage to the MiniLASER. Cable connectors must not be plugged or unplugged, as long as voltage is supplied. Remember to turn voltage supply off before you begin working on cable connections.

2.2. Intended & Conforming Use

- Measurement of distances
- Special measuring functions
- Compliance with prescribed temperatures for operation and storage
- Operation at correct voltage level
- Application of specified signal levels to the appropriate data lines.

2.3. Nonconforming Use

- Do not operate the HiTECH MiniLASER in any other way than described under "Intended & Conforming Use" above and only in a proper working condition.
- Safety devices must not be defeated or otherwise rendered ineffective.
- Information and warning signs must not be removed.

- Repair work on the HiTECH MiniLASER can only be carried out by certified authorized personnel.
- Do not use the HiTECH MiniLASER without certified protection in an explosive environment. Contact HiTECH for approved EX Enclosures.
- Measurement with the HiTECH MiniLASER pointed at the sun or other strong light sources may produce incorrect readings.
- Measurement of targets with poor surface reflectance in a strongly reflecting environment may also result in faulty measurement values.
- Measurement of strongly reflecting surfaces can deliver faulty results.
- Measurement performed through transparent optical media, for example, glass, optical filters, Plexiglas, etc. may equally produce incorrect results.
- Rapidly changing measuring conditions are likely to falsify the result of measurement.

2.4. Laser Classification

The HiTECH MiniLASER is a class 2 laser product as stipulated in IEC825-1/DIN EN 60825-1:2001-11 and a class II product under FDA21 CFR.

Caution:

There is Class 2 Laser radiation. Do not stare into beam!



Figure 2 Laser class 2

The Laser power is limited to 1 mW. In the event of accidental, short-time laser exposure (up to 0.25 s), the human eye is sufficiently protected by its own eyelid winking reflex. This natural reflex may be impaired by medication, alcohol and drugs.

Although the product can be operated without taking special safety precautions, one should refrain from directly looking into the laser beam. Do not direct the laser beam onto persons.

2.5. Electric Supply

Use only 10 VDC to 30 VDC direct voltage for HiTECH MiniLASER power source. Use only the specially designated connector terminal for voltage supply.

Specified signal levels must not be exceeded, in order to guarantee correct data communication.

2.6. Important Operating Advice

To make full use of the system's inherent performance capabilities and achieve a long service life, you should always follow these operating rules:

- Do not turn the module on if there is fogging or soiling on its optical parts!
- Do not touch any of the module's optical parts with bare hands!
- Proceed with care when removing dust or contamination from optical surfaces!
- Prevent shock impacts during and use of the HiTECH MiniLASER.
- Prevent overheating of the HiTECH MiniLASER
- Prevent major temperature variances during HiTECH MiniLASER operation.
- In accordance with NEMA 4 (IP65) internal protection standards, the HiTECH MiniLASER is designed to be splash proof and dustproof.
- Read these safety and operating instructions with due care and follow them in practical use.

3. Technical Data

Measurement range ² :	4.0" (0.1 m) up to 100 feet (30 m) with natural surfaces, depending on target reflectance or reflectors ³ more than 328 feet (100 m) achievable
Measuring accuracy ⁴ :	± 2 mm (0.08") under defined measuring conditions ⁵ ± 3 mm (0.12") +15 °C (59°F) up to +30 °C (86°F), ± 5 mm (0.2") -10 °C (50°F) up to +50 °C (122°F)
Resolution ⁶ :	0.1 mm, (0.004") user scalable
Repeatability:	± 0.5 mm (0.02")
Measuring time:	0.16 up to 6 seconds setup or auto mode DT or 0.1 s (10 Hz) mode DW at white surface or HiTECH MiniLASER HiSPEED 20 ms (50 Hz) mode DX at white surface
Target motion speed:	≤ 5 m/s (16.5 ft/sec.) in DX-Mode (HiTECH MiniLASER HiSPEED)
Acceleration:	≤ 2.5 m/s ² (8.2 ft/sec.) in DX-Mode (HiTECH MiniLASER HiSPEED)
Operating temperature:	- 10 °C (14°F) up to + 50 °C (122°F)
Storage temperature:	- 20 °C (68°F) up to + 70 °C (158°F)
Supply voltage:	10 VDC up to 30 VDC
Power consumption:	depending on operating mode < 0.4 W for standby, < 1,5 W for distance tracking

² dependent on target reflectance, stray light influences and atmospheric conditions

³ e.g. 3M, self adhesive foil white non glossy

⁴ statistic spread 95 %

⁵ for measurement at a planar white target surface in continues movement or still standing, approx. 20 °C

⁶ dependent on target reflectance, stray light influences and atmospheric conditions

Data interface ⁷ :	RS 232/RS 422, baudrate 9600 (2400..38400), ASCII, format 8N1 (fix)
Digital switching output:	"high-side switch", programmable switching threshold and hysteresis, rated for max. load of 0.5 A, HIGH = UB - 2 V, LOW < 2 V
Analog output:	current output 4 mA up to 20 mA programmable distance range limits, load resistance ≤ 500 Ω, accuracy: ± 0.15%, temperature drift: < 50 PPM/°C
Trigger input:	external trigger, trigger pulse 3 up to 24 V, length ≥ 1 ms, start of measurement 5 ms + trigger delay, programmable trigger slope and trigger delay, trigger delay can be set 0 ms ... 9999 ms
EMV:	EN 61000-6-2 und EN 55011
Shock resistance:	10 g / 6 ms persistence shock DIN ISO 9022-3-31-01-1
Laser Class:	Laser Class 2, under IEC825-1 / EN60825, Class I (FDA21 CFR)
Wave length:	650 nm (red visible)
Laser divergence ⁸ :	0,6 mrad
Connector:	12-pol. M18, Binder series 423
Dimensions (L x W x H):	212 x 96 x 50 (mm) 8.35" x 3.78" x 1.97"
Mounting:	100 x 85 (mm), 4 x M6 holes 3.94" x 3.35"
Weight:	ca. 850 g (29.9 oz)
Protection class:	IP 65 (NEMA 4) (spatter water and dust protection) Optional NEMA 4X or NEMA 7

⁷ convertible, conversion to be carried out by certified personnel

⁸ at 10 m distance the beam diameter is 6 mm, at a distance of 50 m it is 3 cm and at a distance of 100 m it is 6 cm

4. Mechanical Mounting Conditions

The casing consists of a rugged, corrosion-resistant extruded aluminum profile with front-side and rear-side covers also in corrosion-resistant design. Four mounting holes are provided in the base plate for mechanical attachment of the MiniLASER .

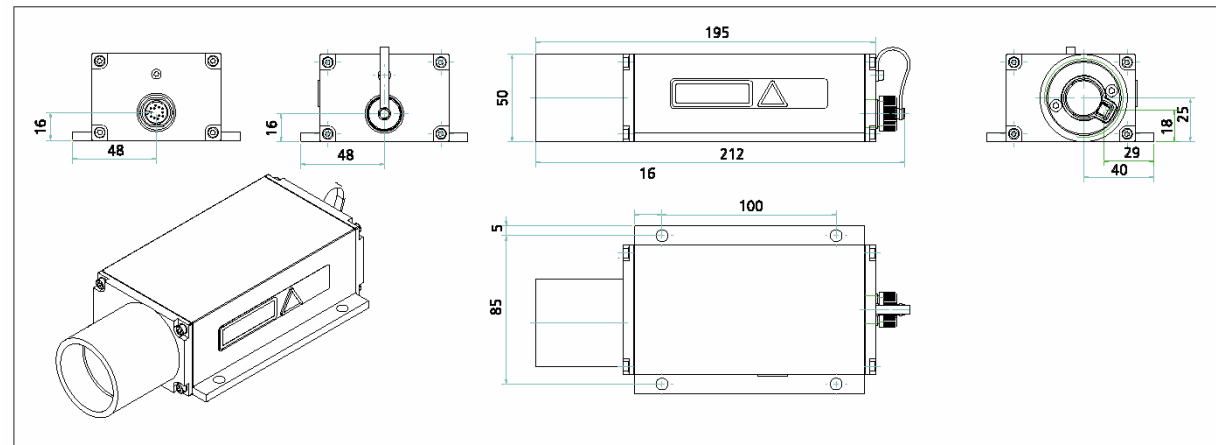

Figure 3 Dimensional drawing

To protect the range finder's optical surfaces from dust, physical contact, mechanical impacts, etc., the casing has a protection tube attached to it. This tube can be extended or removed as necessary to meet the customer's operating needs. Please note that measurement cannot be guaranteed to function correctly if the equalizer tube is removed by unqualified action!

The interface connector is located on the back cover. Interface cables with different lengths are available (standard 2 m (6 ft), optionally 5 (16.5ft or 10 m (33.0 ft)).

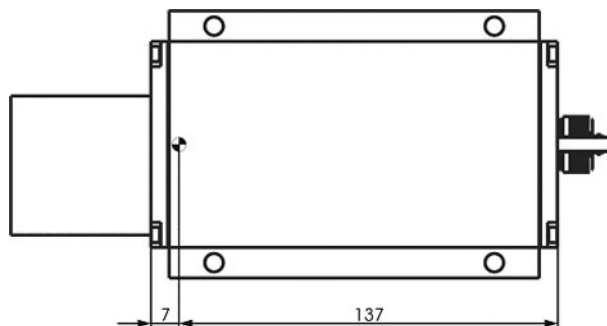

Figure 4 Offset against zero-edge

The MiniLASER's zero-point is located 7 mm (0.275") behind the outer surface of the front cover or 137 mm (5.393") before the back cover outside face respectively. This zero-point has been introduced for constructional design reasons. It can be compensated with the help of parameter "OF" (see section 8.20 OF.....display/set distance offset).

5. Assignments of Connector and Interface Cable

5.1. Connector Terminal

Located on the back cover is a connector terminal. A 12-pole round-type (flange-mount) series 723 connector from Binder has been selected for this purpose. It is sealed against the casing to comply with (NEMA 4) IP 65 requirements. This connector type guarantees optimized screening and a high IP degree.

The required counterpart is a cable jack (series 423 from Binder) with grading ring.

Interface cable with different lengths are available (standard 6.0 feet (2 m), optionally 16.5 feet (5) or 33.0 feet (10 m). Under RS 232 C or RS 422 norm it's possible to extend the length with a high quality screened cable.

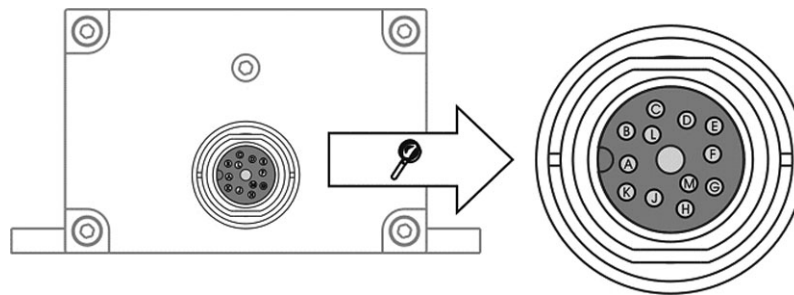

Figure 5 View of MiniLASER A pole assignments

5.2. Interface Cable



Caution:
 The cable end are exposed! The user is responsible to take precautions that will prevent any kind of shorts!
 The cable shield has to be connecting to earth with low resistance.



Figure 6 Interface cable with connector

Interface cable wiring assignments are as follows:

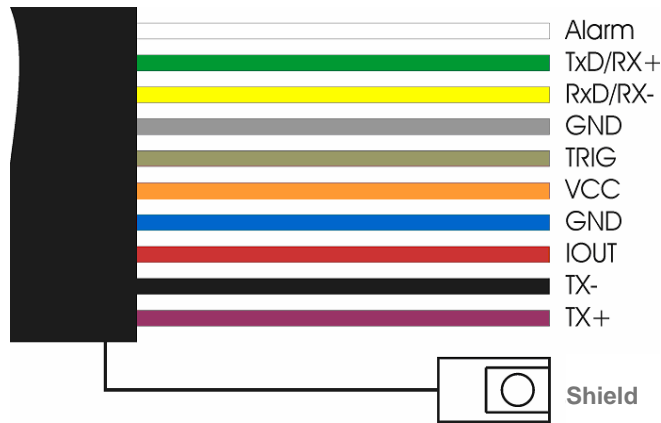

Figure 7 Interface cable colour codes

sw
br
rt
or
ge
gn
bl
vi
gr
ws
Schirm

sw
br
rt
or
ge
gn
bl
vi
gr
ws
Schirm

Pin	Color	Assignment	Function RS 232	Function RS 422
A	Green	TxD / RX+	RS 232 send data	RS 422 receive data +
B	Yellow	RxD / RX-	RS 232 receive data	RS 422 receive data -
C	Brown	TRIG	External trigger input	External trigger input
D	Red	IOUT	Analog output	Analog output
E	Black	TX-	RS 422 send data -	RS 422 send data -
F	Violet	TX+	RS 422 send data +	RS 422 send data +
G	Orange	VCC	Supply voltage	Supply voltage
H	White	ALARM	Digital switching output	Digital switching output
J	Grey	GND	Ground potential	Ground potential
L	Blue	GND	Ground potential	Ground potential

GND wires are connected to an internal collective ground point. They provide the reference potential for all voltage values quoted below.



Caution: If input signals are applied to an output port, this may damage the **MiniLASER**. **Do not connect the current output IOUT (red) to the power supply (10 .. 30 V). This will destroy the interface board!**

For data communication via RS232, you are recommended to use cable 4 (grey, GND) for signal ground and cable 7 (blue, GND) for supply ground!

The limiting values of voltages, load rates and logic levels are in accordance with RS232 and RS422 standard requirements. All outputs are protected against steady short-circuit currents.

5.3. Shield and Grounding

The cable shield must be grounded with low resistance. For cable extension use only high quality shielded cable.

Carrier base and control box should be have equal potential. Potential differences are reason for electrical current and can cause EMC

problems (no correct measurement function or switch off/on of the gauge necessary).

Is no potential equalization possible, mount the MiniLASER isolated (3) from the carrier base (use Nylon screwing and washers).

Use screened cable, e.g. "10XAWG224CULSW", remember to extend also the cable screen (1) ! Connect screen to reference potential of U_v on cable end (2).

For integration with vehicles use this mounting.

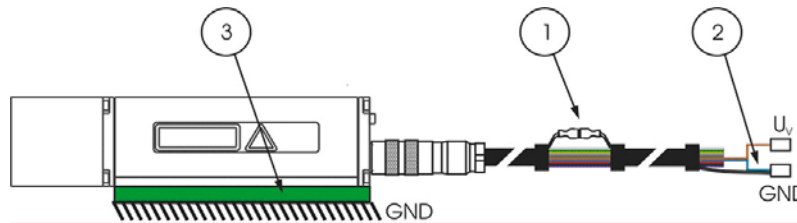
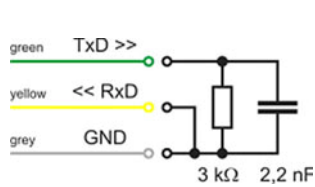

Figure 8 Isolated Montage

5.4. Termination of RS 232

(if not in use or with open terminal points)



Make sure you leave no data line end open. It will be highly sensitive to interferences (EMC).

A terminator circuit should be installed when the RS 232 is unconnected. This circuit must be provided by the customer (see diagram on the left).

Figure 9 Recommended termination wiring for work with open RS232

Please keep the RS 232 norm. The maximal cable length of the RS 232 is 50 feet (15 m). Use alternatively a RS 422 connection (use shielded twisted pair cable, maximum 980 feet (300 m), termination resistor 100 Ω).

6. Limiting Values for Voltages

Input voltages:

Terminal point	Voltage	Comment
VCC	30 V	Pole-reversal-protected
TxD	± 13.2 V	short-circuit-proof
RxD	± 25 V	short-circuit-proof
TX+	± 14 V	short-circuit-proof
TX-	± 14 V	short-circuit-proof
RX+	± 14 V	short-circuit-proof
RX-	± 14 V	short-circuit-proof
TRIG	± 25 V	short-circuit-proof

Output voltages:

Terminal point	Voltage	Comment
TxD	± 5.4 V	± 5 V at 3 k Ω load
TX+, TX-	≥ 2 V	differentially at 2 x 50 Ω load
Alarm	$\geq VCC - 2$ V	Level depending on VCC

All outputs are sustained-short-circuit-proof.



Caution: Do not connect the current output IOUT (red) to the power supply (10 .. 30 V). This will destroy the interface board!

7. Start up

Make sure that all cable ends are protected against short circuit effects before you turn on power supply!
Connect cable terminals as required for the particular operating mode.
To prevent short circuits, you should seal unused cable ends!

For starting up, a PC with RS232 or RS422 data interface and a terminal program are required. We recommend the Windows program LDMT00L Version 1.4 or higher.

As part of preparative actions, the MiniLASER must be properly installed in the designated working site, oriented onto the target and kept in a stable position. The target to be measured should preferentially have a homogeneous, white surface.



Caution: Do not use any retro reflectors!

Alignment of the MiniLASER is facilitated by a laser beam⁹ that is visible and can easily be turned on at the PC.
Operating voltage supply must be connected to the corresponding ends of the interface cable. A pole-reversal protection is integrated to prevent the destruction of electronic components.

⁹ depending on ambient light and target conditions

8. Commands and Parameter

8.1. General

The easiest way to trigger and parameterize the MiniLASER is by using a PC with RS232 communication port and a terminal program (LDMTOOL or HyperTerminal). The communications protocol is available in ASCII format.

Before an operating session begins, desired parameter settings can be made in a smart selection procedure until the measuring module is optimally adapted to the particular measuring site conditions and the measuring job.

By selecting ID[Enter] command, you may call up the menu with available setup commands.

```
LDM4x, s/n xxxxxx, V 3.07

DT[Enter].....distancetracking
DW[Enter].....distancetracking with cooperative target (10Hz)
DF[Enter].....distance measurement with external trigger
DM[Enter].....distance measurement
TP[Enter].....internal temperature [C]
SA[Enter] / SAxx[Enter]...display/set average value [1..20]
SD[Enter] / SDxx[Enter]...display/set display format [d/h]
ST[Enter] / STxx[Enter]...display/set measure time [0..25]
SF[Enter] / SFx.x[Enter]...display/set scale factor
SE[Enter] / SEx[Enter]....display/set error mode [0/1/2]
                        0..Iout=const., ALARM=const.
                        1..Iout: 4mA @RE>RB, 20mA @RE<RB, ALARM:
                           OFF@AH>0, ON@AH<0
                        2..Iout: 20mA @RE>RB, 4mA @RE<RB, ALARM:
                           ON@AH>0, OFF@AH<0
AC[Enter] / ACx.x[Enter]...display/set ALARM center
AH[Enter] / AHx.x[Enter]...display/set ALARM hysteresis
RB[Enter] / RBx.x[Enter]...display/set distance of Iout=4mA
RE[Enter] / REx.x[Enter]...display/set distance of Iout=20mA
TD[Enter] / TDxx x[Enter]..display/set trigger delay [0..9999ms]
                        trigger level [0/1]
BR[Enter] / BRxxxx[Enter]..display/set baud rate [2400..38400]
AS[Enter] / ASdd[Enter]....display/set autostart command
                        [DT/DW/DF/DM/TP/LO/ID]
OF[Enter] / OFx.x[Enter]...display/set distance offset
SO[Enter].....set current distance to offset
                        (offset = - distance)
LO[Enter].....laser on
LF[Enter].....laser off
PA[Enter].....display settings
PR[Enter].....reset settings
```

Figure 10 Help text

All valid settings will be preserved on turning the MiniLASER off! They can only be replaced with new value entries or changed back to their standard values by running an initialization routine.

Command entries are not case-sensitive. This means that small and capital lettering can be used for commands.

Any command must be terminated by a hexadecimal 0Dh (carriage return) character.

Where decimal digits are to be entered, they must be separated by period (2Eh).

For command parameter entries, one must distinguish between parameter settings and parameter queries.

Querying is achieved with a command in simple format, e.g. (for alarm center parameters):

AC[Enter]

For parameter setting, a new value must be added after the command with no delimitation sign in between, for example:

AC20.8[Enter]

In the given example, the alarm center will be set to 20.8.

The following is a short overview of the commands:

Command	Description
DT	Starts distance tracking
DW	Starts distance tracking on white target at 10 Hz
DX	Starts distance tracking on white target at 50 Hz (only MiniLASER HiSPEED)
DF	Starts remote-triggered single distance measurement (single shot)
DM	Starts single distance measurement (single shot)
TP	Queries inner temperature
SA	Queries / sets floating average value (1...20)
SD	Queries / sets output format (dec/hex)
ST	Queries / sets time to measure (0...25)
SF	Queries / sets scale factor

SE	Queries / sets error mode (0, 1, 2)
AC	Queries / sets alarm center
AH	Queries / sets alarm hysteresis
RB	Queries / sets beginning of range (4 mA)
RE	Queries / sets end of range (20 mA)
TD	Queries / sets trigger delay
BR	Queries / sets baud rate
AS	Queries / sets autostart
OF	Queries / sets offset
SO	Sets current distance as offset
LO	Turns laser on
LF	Turns laser off
PA	Displays all parameter values
PR	Resets all parameters to standard values

8.2. DT.....distance tracking

Input parameter SA, SD, SE, SF, ST, OF

Output RS232/RS422, digital switching output, analog output

DT mode can be chosen for distance measurement of different kinds of surfaces (varying reflectance). In this type of distance tracking mode, the HiTECH MiniLASER uses internal algorithms to continuously evaluate the quality of the laser radiation signal that is coming back. This may cause longer measuring times in the case of poor reflectance or sudden jumps in distance.

The minimum time to measure is 160 ms, the maximum time is 6 s. If the measuring signal fails to reach a specified quality within six seconds, an error message is output.

The time to measure may also be limited by setting the ST parameter to a desired value.

ESC stops the measurement.

8.3. DW.....distance tracking with cooperative target (10Hz)

Input parameter SA, SD, SE, SF, OF

Output RS232/RS422, digital switching output, analog output

DW mode performs at a steady measuring rate of 10 Hz.

The selected object must have a white target board for measured values to be stable!

ESC stops the measurement.

8.4. DX.....distance tracking with cooperative target (50Hz)

Input parameter SA, SD, SE, SF, OF

Output RS232/RS422, digital switching output, analog output

DX mode performs at a steady measuring rate of 50 Hz. The selected object must have a white target board for measured values to be stable! ESC stops the measurement.

8.5. DF.....distance measurement with external trigger

Input parameter SA, SD, SE, SF, ST, OF

Output RS232/RS422, digital switching output, analog output

DF mode allows a measurement that is triggered by an external trigger pulse.

Initially, after selecting this mode, the operator does not receive any response. As soon as the trigger pulse has been detected, the MiniLASER A will send data and switches to digital and/or analog output.

Settings for trigger delay (delay) and trigger slope can be defined via parameter TD. (see 8.17 TD.....display/set trigger delay [0..9999ms] trigger level [0/1])

8.6. DM.....distance measurement

Input parameter SA, SD, SE, SF, ST, OF

Output RS232/RS422, digital switching output, analog output

DM mode triggers a single measurement (single shot).

8.7. TP.....internal temperature [°C]

TP queries the value of the inner LDM 41/42 A temperature.

Note: In tracking mode, the inner temperature may exceed the surrounding temperature level by as much as 10 K.

8.8. SA.....display/set average value [1..20]

SA allows you to calculate a floating average value from 1 to 20 measured values.

Calculation is based on this formula.

$$\text{Average value } x = \frac{X_1 + X_2 + X_3 + \dots + X_n (20)}{n}$$

Standard setting is 1.

8.9. SD.....display/set display format [d/h]

SD switches between decimal (d) and hexadecimal (h) output format of measured value data. SD affects all commands that output a distance value.

A hexadecimal output value is calculated from a given measured distance value (in mm), multiplied by the scale factor SF.

Hex-Format: <SPACE>xxxxxx<CR><LF>, x=0...F.

Negative distance values are output in two's complement notation.

Examples:

Distance = 4,996 m, SF1

dec: 004,996<CR><LF>

hex: _001384<CR><LF> (= 4996 mm × SF1)

Distance = 4,996 m, SF10

dec: 049,960<CR><LF>

hex: _00C328<CR><LF> (= 49960 = 4996 mm × SF10)

8.10. ST.....display/set measure time [0..25]

Measuring time is directly conditional on the selected measuring mode.

As a general rule, one may say: the poorer the reflectance of the surface of a particular target, the more time the MiniLASER will require to determine the distance with specified accuracy. For example, if error

message E15 is output because of poor reflectance and insufficient time to measure, this latter setting must be increased. The available value range for measuring time is 0 to 25. Basically, the greater the time setting is the more time will be available for measurement and the lower the resulting measuring rate. An exception there from is zero-value. In this case, the MiniLASER automatically picks the smallest possible time value for measurement! The MiniLASER comes factory-set with ST = 0. ST is effective in the DT, DF and DM mode of operation. The measuring time setting option can also be used to modify the measuring rate, for example, in order to restrict the data volume or for synchronization purposes. The following sample time setting can only be regarded as providing an approximate value:

Measuring time \approx ST-240 ms (except ST=0)

Example:

The target distance is 82 feet (25 m), but the target's reflectance is not ideal. With a measuring time setting of ST 2, E15 will be output following measurement. The user must increase the time to measure in this case!

8.11. SF.....display/set scale factor

SF multiplies a calculated distance value with a user-selectable factor for changes in resolution or outputs in a different unit of measure. The scale factor may also be negative. Standard setting is 1.

The scale factor influence the output of measurement results, Offset (OF), Alarm Centre (AC), Alarm Hysteresis (AH), Range Begin (RB) and Range End (RE)!

Scale factor	Resolution	Output	Output Unit
SF1	1 mm	12,345	M
SF10	0,1 mm	123,45	Dm
SF1.0936	0,01 yard	13.500	Yard
SF3.28084	0,01 feet	40.501	Feet
SF0.3937	1 inch	4.860	100 inch
SF-1	1 mm	-12.345	M



Note: Following a change in the scale factor, the settings for digital and/or analog output and offset must be matched accordingly!

8.12. SE.....display/set error mode [0/1/2]

SE (error mode) allows you to configure the behaviour of the digital switching output (alarm) and/or the analog output following an error message (E15, E16, E17). Depending on the particular MiniLASER application environment, error messages have to be handled in different ways.

Available setting options are 0, 1 and 2 with the following effects in the case of an error:

SE	Digital switching output (Alarm)	Analog output (4 ... 20 mA)
0	Hold voltage level of latest valid measurement	Outputs current of latest valid measurement
1	Positive alarm hysteresis = LOW- Negative alarm hysteresis = HIGH	RE >RB: Current =4 mA RE <RB: Current =20 mA
2	Positive alarm hysteresis = HIGH- Negative alarm hysteresis = LOW	RE >RB: Current =20 mA RE <RB: Current =4 mA

8.13. AC.....display/set ALARM center

AC corresponds to the distance, on identification of which the switching output switches. AC must be defined taking into consideration the currently valid scale factor (SF) value.

As soon as the predefined distance threshold is negatively or positively exceeded, the alarm output will switch from HIGH to LOW or vice versa with a certain delay as set under alarm hysteresis (AH).
(see 8.28 Digital Switching Output)

8.14. AH.....display/set ALARM hysteresis

AH sets the switching hysteresis of the switching output.

AH must be selected so it is properly matched to the currently valid scale factor (SF). As soon as the predefined distance threshold is negatively or positively exceeded, the alarm output will switch from

HIGH to LOW or vice versa with a certain delay as set under alarm hysteresis (AH) (see 8.28 Digital Switching Output).

8.15. RB.....display/set distance of lout = 4mA

RB (Range Begin) defines the point of a distance range at which the analog output will begin to deliver varying distance readings.

At a distance of RB, the output current will be 4 mA.

RB must be selected so it is properly matched to the currently valid scale factor (SF) setting.

RB can be smaller or greater than RE! (see 8.29 Analog output!)

8.16. RE.....display/set distance of lout = 20mA

RE (Range End) defines the point of a distance range at which the analog output will cease to deliver varying distance readings.

At a distance of RE, a current of 20 mA will be output.

RE must be selected so it is properly matched to the currently valid scale factor (SF) value. RE can be greater or smaller than RB!

8.17. TD.....display/set trigger delay [0..9999ms] trigger level [0/1]

TD is only intended for the configuration of the remote trigger input (see 8.5 DF mode).

TD consists of two sub parameters, of the actual delay value, i.e. the delay time, and the trigger level.

Trigger delay corresponds to the time from arrival of the trigger signal to the starting point of a measurement. It may be set to any value between 0 and 9999 ms. With the help of the trigger level one may define if measurement is to begin on a rising or a falling pulse slope.

Trigger delay and trigger level must be separated by space (20h) in the entry line. Standard setting: 0 0.

Example:

```
TD1000_60[Enter]
```

In the given example, the delay has been set to 1000 ms and the trigger slope to "rising" (LOW-to-HIGH transition).

8.18. BR.....display/set baud rate [2400..38400]

Available baud rate settings are: 2400, 4800, 9600, 19200, 38400.

Faulty entries will be rounded to the nearest baud rate.
A fixed data format of eight data bits, with no parity and one stop bit is used. Standard setting is 9600 baud.

8.19. AS....display/set auto start command

AS (auto start) defines which function will be carried out when power becomes available to the MiniLASER .
Possible entries are those delivering a measured value on the output side, an ID command or the command for turning the laser on (LO).
For example, if ASDT has been parameterized, the MiniLASER will begin with distance tracking on turning on power.

8.20. OF.....display/set distance offset

With the help of OF (offset) the user may define a zero-point for his/her application. For details on the position of the module's zero-point, refer to section 4.
OF must be selected so it is properly matched to the currently valid scale factor setting (SF).
OF may also take on negative values. Standard setting: 0

8.21. SO.....set current distance to offset (offset = - distance)

SO performs a distance measurement and saves the measured reading as an offset value with inverted mathematical sign (OF).

8.22. LO.....laser on

LO turns the laser on. This function can be used for orientation or functional testing of the MiniLASER.

8.23. LF.....laser off

LF turns the laser off.

8.24. PA.....display settings

PA lists all parameters in a table.

8.25. PR.....reset settings

PR resets all parameters (except for baud rate). After a new configuration of the MiniLASER

Interface connection

8.26. Serial Interface RS232

Initially, RS232 communication interfaces purely functioned as PC communication ports. They have become the established standard tool for serial data transmission over short cable lengths. With greater transmission lengths, the interface is highly susceptible to interferences, notably, in the vicinity of strong electromagnetic noise emitters. Therefore, it should only be used for MiniLASER configuration.

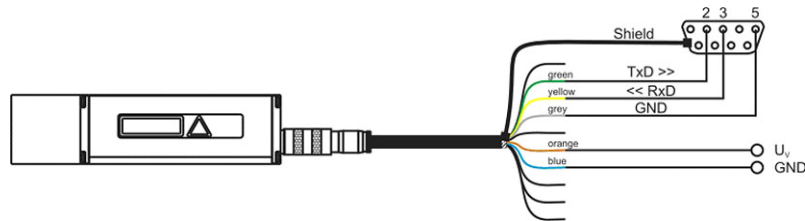

Figure 11 Diagram of RS232 wiring at 9-position D-Sub cable jack

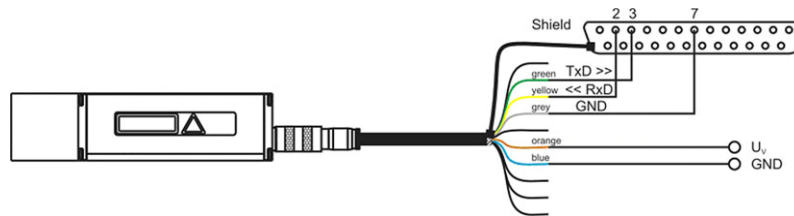

Figure 12 Diagram of RS232 wiring at 25-pole D-Sub cable jack

8.27. Serial Interface RS422

For configuration purposes and permanent data transmissions over a greater length, the RS422 can be used. This type of interface is insusceptible to interference and noise influences and qualifies for industrial use. Where twisted cable pairs are involved, transmissions lengths up to 300 m can be handled.

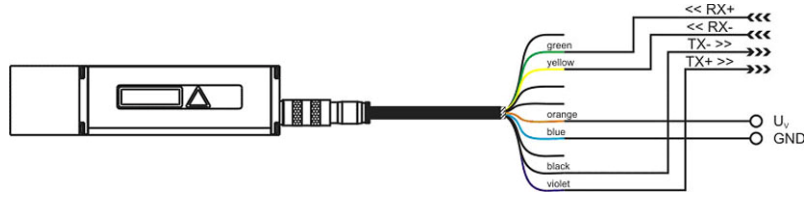

Figure 13 RS422 wiring diagram

Since a standard PC typically includes no RS422 communication port, you require an RS422 interface card or an RS422-to-RS232 converter for communication.

8.28. Digital Switching Output (Alarm)

With the help of a user-selectable distance threshold, the switching output can be set to monitor objects or conditions for positive or negative overstep.

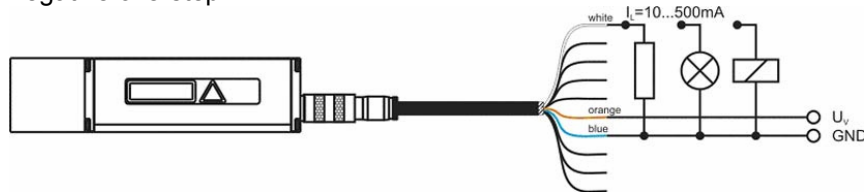

Figure 14 Wiring diagram of digital switching output

The output can supply up to 500 mA.

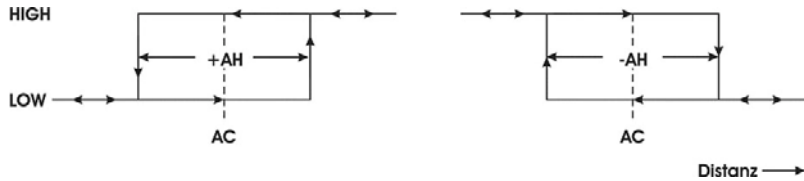

Figure 15 Digital switching output with positive and negative hysteresis

Configuration settings to this end can be made in “Alarm Center“ (AC see 8.13) and “Alarm Hysteresis“ (AH see 8.14).

Of decisive significance for the switching output’s logic state is the mathematical sign of the hysteresis condition. It can be used as a quasi-inverter of the switching output. In the case of positive hysteresis, the

output changes from LOW to HIGH condition with increasing distance if $AC + AH/2$ was positively exceeded, and from HIGH to LOW with decreasing distances if $AC - AH/2$ was negatively exceeded. In the case of negative hysteresis, the output changes from HIGH to LOW with increasing distance if $AC + |AH/2|$ was positively exceeded, and from LOW to HIGH with decreasing distance if $AC - |AH/2|$ was negatively exceeded.

Example:

AC	AH	0,8 m	0,9 m	1,0 m	1,1 m	1,2 m	1,1 m	1,0 m	0,9 m	0,8 m
1 m	(+) 0,2 m	L	L	L	H	H	H	H	H	L
1 m	- 0,2 m	H	H	H	L	L	L	L	L	H

L = Low, H = High

How the switching output is to behave on occurrence of an error message (E15, E16, E17, E18) can be defined by making suitable settings under "SE".

8.29. Analog Output

The analog output is designed to allow normalized analog distance data transmission over greater length via a two-wire cable.

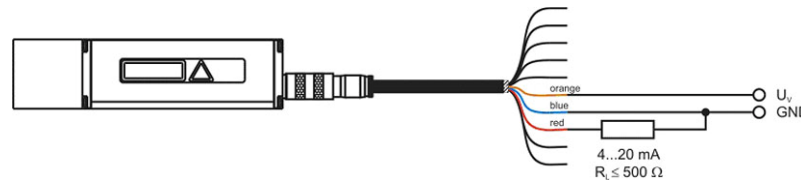

Figure 16 Wiring diagram of analog output

The analog output is designed to allow normalized analog distance data transmission over greater length via a two-wire cable.

The current is proportional to the measured target distance. This applies within a distance interval that is marked by the two limiting parameters "Range Begin" (RB) and "Range End" (RE), where RE may be greater or smaller than RB (see 8.15 and 8.16).

The output current value is calculated according to this equation:

$$RE > RB: I_{OUT} [mA] = 4 \text{ mA} + 16 \cdot \left(\frac{\text{Distanz} - RB}{RE - RB} \right) \cdot \text{mA}$$

$$RE < RB: I_{OUT} [mA] = 20 \text{ mA} - 16 \cdot \left(\frac{\text{Distanz} - RE}{RB - RE} \right) \cdot \text{mA}$$

If RB is negatively exceeded (in RE > RB direction) or positively exceeded (in RE < RB direction) by the actual distance value, the analog output current will be 4 mA.

If RE is positively exceeded (in RE > RB direction) or negatively exceeded (in RE < RB direction) by the actual distance value, the analog output current will be 20 mA.

Example:

RB	RE	0 m	2 m	4 m	6 m	8 m	10 m	11 m
2 m	10 m	4 mA	4 mA	8 mA	12 mA	16 mA	20 mA	20 mA

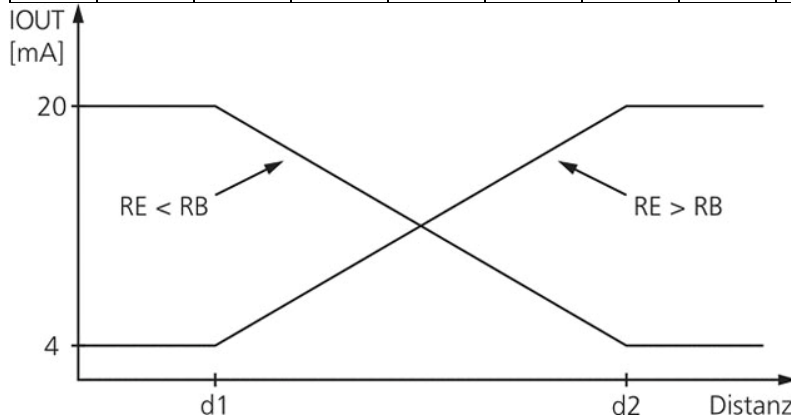

Figure 17 Output current diagram for RE > RB and RE < RB

To match analog output behavior in the event of an error message (E15, E16, E17, E18), appropriate settings can be made under "SE" (i 4.2.11).

8.30. Trigger Input

The trigger input is intended for triggering a distance measurement with an external signal that is applied as a voltage pulse between 3 V and 24 V.



Figure 18 Wiring diagram of trigger input

The user to specifies a desired delay time and a pulse flank to be selected for synchronization (see 8.17). Having done this, he/she must switch the MiniLASER to trigger mode (DF see 8.5).

9. List of Commands

Command	Description
DT	Starts distance tracking
DW	Starts distance tracking on white target at 10 Hz
DX	Starts distance tracking on white target at 50 Hz (only MiniLASER HiSpeed)
DF	Starts remote-triggered single distance measurement (single shot)
DM	Starts single distance measurement (single shot)
TP	Queries inner temperature
SA	Queries / sets floating average value (1...20)
SD	Queries / sets output format (dec/hex)
ST	Queries / sets time to measure (0...25)
SF	Queries / sets scale factor
SE	Queries / sets error mode (0, 1, 2)
AC	Queries / sets alarm center
AH	Queries / sets alarm hysteresis
RB	Queries / sets beginning of range (4 mA)
RE	Queries / sets end of range (20 mA)
TD	Queries / sets trigger delay
BR	Queries / sets baud rate
AS	Queries / sets autostart
OF	Queries / sets offset
SO	Sets current distance as offset
LO	Turns laser on
LF	Turns laser off
PA	Displays all parameter values
PR	Resets all parameters to standard values

10. Error Codes

Code	Description	Action
E15	Reflexes are too weak, or distance from MiniLASER (front edge) to target is less than 0.1 m	Use white target ¹⁰ board or increase distance to target
E16	Reflexes are too strong	Use white target board or filter
E17	Too much steady light (e.g. sun) or reflexes are too strong	Use aperture or filter or white target board
E18	DX mode (only MiniLASER HiSpeed): reflexes too weak, or distance from MiniLASER (front edge) to target is less than 0.1 m	Use white target board or increase distance to target
E23	Inner temperature below – 10°C	Heating necessary
E24	Inner temperature above + 60°C	Cooling necessary
E31	EEPROM checksum	Necessary to repair
E51	Failed to set avalanche voltage	Necessary to repair
E52	Excessively high laser current/laser defect	Necessary to repair
E53	Division by 0	Necessary to repair
E54	PLL range	Necessary to repair
E55	Unknown error	Necessary to repair
E61	Faulty command	Correct input
E62	Illegal parameter, invalid command	Correct input
E63	SIO parity error	Check data transmission
E64	SIO framing error	Check data transmission

¹⁰ e.g. 3M, self adhesive foil white non glossy

11. PC Interface Cable (Option)

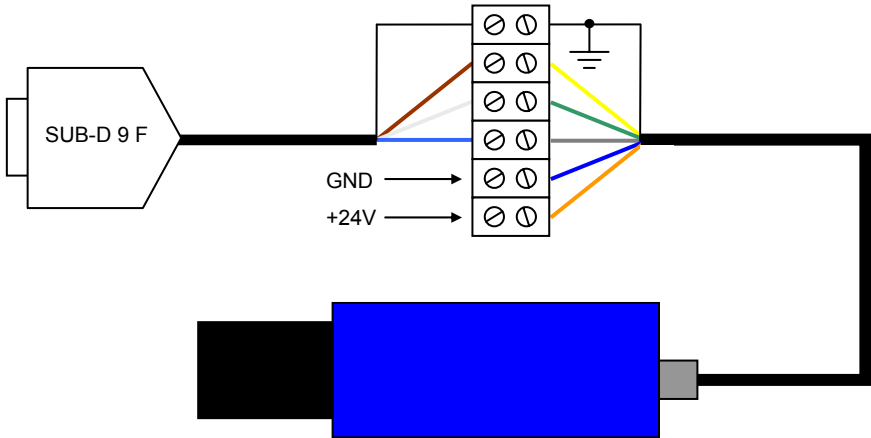

Figure 19 RS 232 cable with power supply for **MiniLASER**

No.	SUB-D 9 F	Colour code	Designation SUB-D 9 F (PC COM)
	Shield	-	Cable shield
	3	Brown	TxD
	2	White	RxD
	5	Blue	GND

Pin MiniLASER	Colour code	Designation MiniLASER / RS 232
Shield	-	Cable shield
A	White	ALARM
B	Green	TxD / RX+
J	Yellow	RxD / RX-
C	Grey	GND
D	Brown	TRIG
E	orange or pink	VCC
F	Blue	GND
G	Red	IOOUT
H	Black	TX-
L	Violet	TX+



Please use only high quality shielded cable.
RS 232 Cable: TxD and RxD are necessary to cross.

12. Service and Warranty

We grant a **two-year** warranty period for this product. In the event of necessary repair work before or after these scheduled dates, you should contact HiTECH Technologies, Inc. service department for a proper RMA number and then carefully pack your MiniLASER and return it to us. Please state all operating conditions (error description, applications, connectivity details, environmental conditions).