

# HITECH

Technologies, Inc.

**EchoTREK™**  
THE NEXT GENERATION

**SMART**

## TWO-WIRE LEVEL TRANSMITTER

Model SE/SG-300

*SonicLaser™ Sensing Technology*

IDEAL for:

- ◆ Breweries
- ◆ Chemicals
- ◆ Food Processing
- ◆ Pharmaceuticals
- ◆ Power Plants
- ◆ Pulp & Paper
- ◆ Water & Wastewater



### ADVANTAGES

- **Narrow Beam Angle** ( $\pm 2.5^\circ$  from center axis)
- **Built-in temperature compensation**
- **Simple intuitive programming**
- **Fixed target suppression**
- **32-point linearization**
- **4 to 20 mA output**
- **Operating modes:**

Basic: Simple start up and 4/20 mA programming without Display Module option.

Sophisticated: Using the Display Module (SAP-200) which includes a 6 digit custom LCD display, the operator can choose between a menu driven QUICKSET or full parameter programming.

The SE/SG-300 series of **EchoTREK™** is **HITECH's** new line of TWO-WIRE Loop-Powered SMART ultrasonic level transmitters using unique **SonicLaser™** technology. The Two-Wire **EchoTREK™** combined with the optional **Solar Power Package** is the ideal solution for applications in remote locations.

**EchoTREK™** compact transmitters include the latest version of the field proven **QUEST II™** advanced, process adaptive signal processing software to identify and validate the surface signal.

**HITECH's SonicLaser™**, utilizing unique patented technology, is the best ultrasonic level measurement system on the market today. Presently there are more than 20,000 narrow beam **SonicLaser™** sensors, operating successfully worldwide, in various harsh industrial processing environments.



**HITECH** Technologies, Inc.

301 Oxford Valley Road, Yardley, PA 19067-7706

Technical support: 800. 755. 4507

Tel: 215. 321. 6012 Fax: 215. 321. 6067 - [www.hitechtech.com](http://www.hitechtech.com)

# HITECH

Technologies, Inc.

**EchoTREK™**  
THE NEXT GENERATION

**SMART**

## TWO-WIRE LEVEL TRANSMITTER

Model SE/SG-300

### SPECIFICATIONS

<b>Model</b>	<b>Range</b>	<b>Power supply / Consumption</b>
xxx- 39	8" to 13 feet (0.2 to 4 meters)	11.4 ...36 VDC / 48 mW ...720 mW
xxx- 38	10" to 20 feet (0.25 to 6 meters)	Electrically isolated and surge/transient protected
xxx- 37	14" to 26 feet (0.35 to 8 meters)	Optional Solar Power Package
<b>Accuracy *</b>	± (0.2% of the measured distance plus 0.05% of the range)	<b>Materials</b>
		Transducer: Polypropylene (PP) or Kynar (PVDF)
		Housing: Plastic (PBT fibreglass reinforced) or Aluminium (Powder paint coated)
<b>Resolution (Dependent upon measured distance)</b>		<b>Temperature</b>
< 80 inches: 0.04 inches		Process: -22 °F ...+194 °F
80...198 inches: 0.08 inches		Ambient: -22 °F ...+140 °F
16.4...26 feet: 0.2 inches		w/SAP-200: -13 °F ...+140 °F
<b>Analog:</b>		<b>Pressure (Absolute)</b>
4 ...20 mA, Rmax 600 Ohm		0.5** ... 3 bar (0.05 ... 0.3 MPa)
<b>Loop power test connectors:</b>		<b>Seals</b>
Ammeter plug-in, 200 mV, 0.5%		PP transducer: EPDM
		PVDF transducer: FPM (Viton)
<b>Display:</b>		<b>Rating</b>
6 digits, icons & bargraph, (SAP-200 module)		Sensor: NEMA 4X & 6
		Housing:NEMA 6

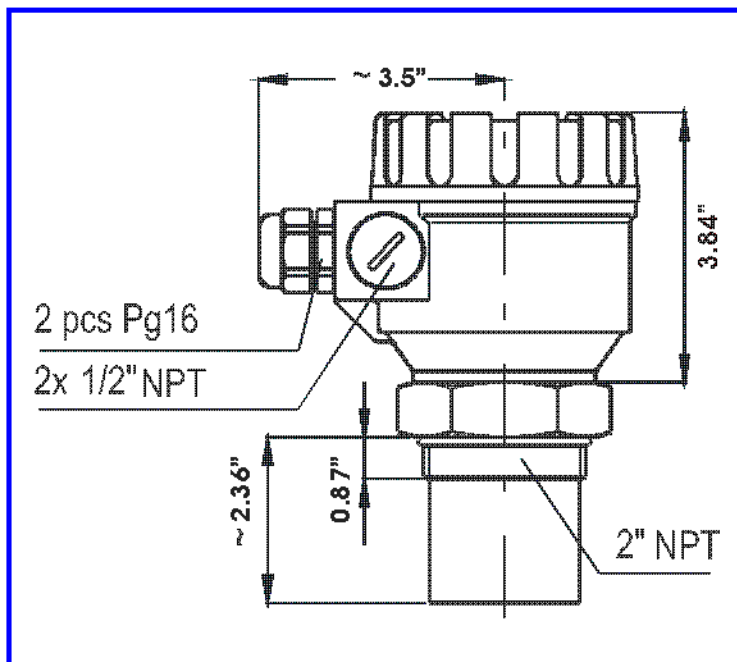

### PERFORMANCE GUARANTEE

Since 1986, every instrument sold by **HITECH** has been guaranteed to perform in the application it originally was engineered and recommended for. Our company policy remains the same, every product sold comes with a written performance guarantee.

Should the equipment be unable to perform satisfactorily in your application and we are not able to correct the problem, we will accept the instrument in return and issue full credit.

This performance guarantee is valid for 60 days. Thereafter, our standard limited two years factory warranty goes into effect.

Copyright HITECH Technologies, Inc. 2000



**HITECH** Technologies, Inc.

301 Oxford Valley Road, Yardley, PA 19067-7706

Technical support: 800. 755. 4507

Tel: 215. 321. 6012 Fax: 215. 321. 6067 - www.hitechtech.com