

Operating Instructions

VEGAFLEX 65

4 ... 20 mA/HART - Four-wire

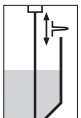

Contents

1 About this document

1.1	Function	4
1.2	Target group	4
1.3	Symbolism used	4

2 For your safety

2.1	Authorised personnel	6
2.2	Appropriate use	6
2.3	Warning about misuse	6
2.4	General safety instructions	6
2.5	CE conformity	6
2.6	Safety information for Ex areas	7
2.7	Environmental instructions	7

3 Product description

3.1	Configuration	8
3.2	Principle of operation	9
3.3	Adjustment	9
3.4	Storage and transport	9

4 Mounting

4.1	General instructions	11
4.2	Mounting procedure	13

5 Connecting to power supply

5.1	Preparing the connection	15
5.2	Connection procedure	16
5.3	Wiring plans, double chamber housing	18

6 Set-up with the indicating and adjustment module PLICSCOM

6.1	Short description	20
6.2	Installing the indicating and adjustment module PLICSCOM	20
6.3	Adjustment system	22
6.4	Set-up procedure	23
6.5	Menu schematic	26

7 Set-up with PACTware™

- 7.1 Connecting the PC 29
- 7.2 Parameter adjustment with PACTware™ . . . 31

8 Maintenance and fault rectification

- 8.1 Maintenance 32
- 8.2 Fault rectification 32
- 8.3 Repairing the instrument 33

9 Dismounting

- 9.1 Dismounting procedure 34
- 9.2 Disposal 34

10 Supplement

- 10.1 Technical data 35
- 10.2 Dimensions 41

1 About this document

1.1 Function

This operating instructions manual has all the information you need for quick set-up and safe operation of VEGAFLEX 65. Please read this manual before you start set-up.

1.2 Target group

This operating instructions manual is directed to trained personnel. The contents of this manual should be made available to these personnel and put into practice by them.

1.3 Symbolism used



Information, tip, note

This symbol indicates helpful additional information.



Caution, warning, danger

This symbol informs you of a dangerous situation that could occur. Ignoring this cautionary note can impair the person and/or the instrument.



Ex applications

This symbol indicates special instructions for Ex applications.



List

The dot set in front indicates a list with no implied sequence.



Action

This arrow indicates a single action.

1 **Sequence**

Numbers set in front indicate successive steps in a procedure.

2 For your safety

2.1 Authorised personnel

All operations described in this operating instructions manual must be carried out only by trained and authorised specialist personnel. For safety and warranty reasons, any internal work on the instruments must be carried out only by VEGA personnel.

2.2 Appropriate use

VEGAFLEX 65 is a sensor for continuous level measurement.

2.3 Warning about misuse

Inappropriate or incorrect use of the instrument can give rise to application-specific hazards, e.g. vessel overfill or damage to system components through incorrect mounting or adjustment.

2.4 General safety instructions

VEGAFLEX 65 is a high-tech instrument requiring the strict observance of standard regulations and guidelines. The user must take note of the safety instructions in this operating instructions manual, the country-specific installation standards (e.g. the VDE regulations in Germany) as well as all prevailing safety regulations and accident prevention rules.

2.5 CE conformity

VEGAFLEX 65 is in CE conformity with EMC (89/336/EWG), R & TTE guideline (1999/5/EC), fulfils the Namur recommendation NE 21 and is in CE conformity with NSR (73/23/EWG).

Conformity has been judged acc. to the following standards:

- EMC:
 - Emission EN 61326: 1997 (class B)
 - Susceptibility EN 61326: 1997/A1: 1998
- R & TTE guideline: I-ETS 300-440 Expert opinion No. 0043052-02/SEE, Notified Body No. 0499
- NSR: EN 61010-1: 2001

2.6 Safety information for Ex areas

Please note the Ex-specific safety information for installation and operation in Ex areas. These safety instructions are part of the operating instructions manual and come with the Ex-approved instruments.

2.7 Environmental instructions

Protection of the environment is one of our most important duties. That is why we have introduced an environment management system with the goal of continuously improving company environmental protection. The environment management system is certified acc. to DIN EN ISO 14001.

Please help us fulfil this obligation by observing the environmental instructions in this manual:

- Chapter "Storage and transport"
- Chapter "Disposal"

3 Product description

3.1 Configuration

Scope of delivery

The scope of delivery encompasses:

- VEGAFLEX 65 level sensor
 - documentation
 - this operating instructions manual
 - Ex-specific safety instructions (with Ex versions)
- and, if necessary, further certificates.

Components

VEGAFLEX 65 consists of the following components:

- process fitting with probe
- housing with electronics
- housing cover, optionally available with indicating/adjustment module PLICSCOM

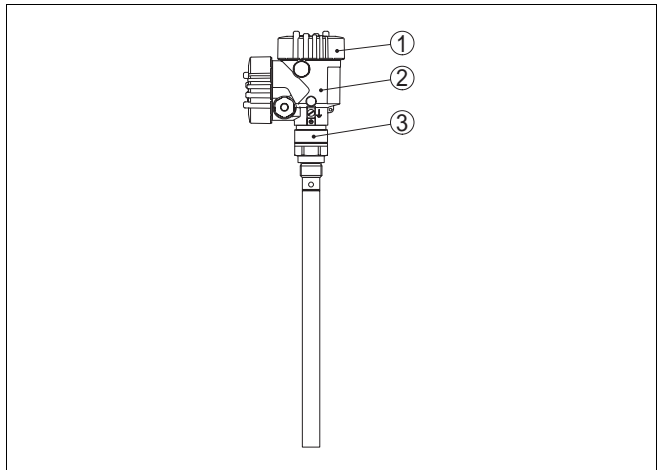

Fig. 1: VEGAFLEX 65 with plastic housing

- 1 Housing cover with integrated PLICSCOM (optional)
- 2 Housing with electronics
- 3 Process fitting

3.2 Principle of operation

Area of application

VEGAFLEX 65 is a level sensor with pipe electrode for continuous level measurement.

It is designed for industrial use in all areas of process technology and can be used in liquids.

Physical principle

High frequency microwave pulses are guided along a steel cable or rod. When reaching the product surface, the microwave pulses are reflected. The pulse running time is processed by the instrument and outputted as distance.

Power supply

Four-wire electronics with separate power supply.

The power supply range can differ depending on the instrument version. The exact range is stated in the Technical data in the Supplement.

The measured value transmission is carried out via the 4 ... 20 mA/HART output separated from the power supply.

3.3 Adjustment

VEGAFLEX 65 can be adjusted with three different adjustment media:

- with the indicating and adjustment module PLICSCOM
- with an adjustment software acc. to FDT/DTM standard, e.g. PACTware™ and PC
- with a HART handheld

The entered parameters are generally saved in VEGAFLEX 65, optionally also in PLICSCOM or in PACTware™.

3.4 Storage and transport

Packaging

Your instrument was protected by packaging during transport. Its capacity to handle normal loads during transport is assured by a test acc. to DIN 55439.

The packaging consists of environment-friendly, recyclable cardboard. Dispose of the packing material via specialised recycling companies.

Material:

Storage and transport temperature

- Packaging of cardboard
- Padding of cardboard or PE foam
- Storage and transport temperature, see Supplement, Technical data, Ambient conditions
- Relative humidity 20 ... 85 %

4 Mounting

4.1 General instructions

Installation position

Select an installation position you can easily reach for mounting and connecting as well as later retrofitting of an indicating and adjustment module PLICSCOM. The housing can be rotated by 330° without the use of any tools. You can also install the indicating and adjustment module PLICSCOM in four different positions (each displaced by 90°).

Moisture

Use the recommended cable (see chapter "Connecting to power supply") and tighten the cable entry.

You can also protect your VEGAFLEX 65 against moisture penetration by leading the connection cable downward in front of the cable entry. Rain and condensation water can thus drain off. This applies mainly to mounting outdoors, in areas where moisture is expected (e.g. by cleaning processes) or on cooled or heated vessels.

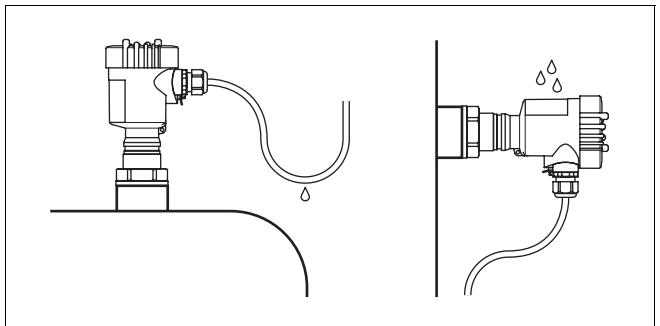

Fig. 2: Measures against moisture penetration

Measuring range

The reference plane for the sensor measuring range is the seal surface of the thread.

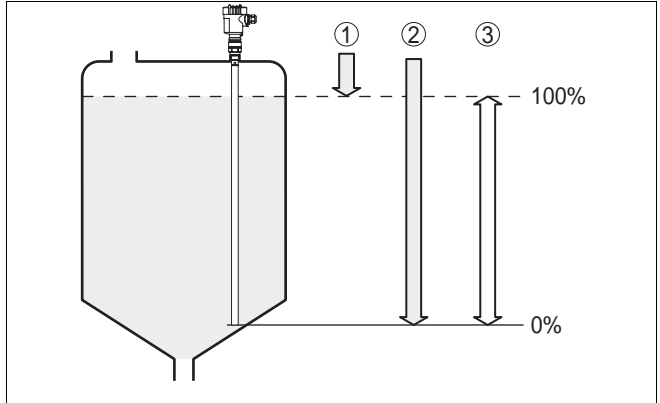

Fig. 3: Measuring range (operating range) and max. measuring distance

- 1 full
- 2 empty (max. measuring distance)
- 3 Measuring range

Keep in mind that a min. distance is maintained below the reference plane and, if possible, on the electrode end in which a measurement is not possible. These min. distances are stated in the Technical data in the Supplement.

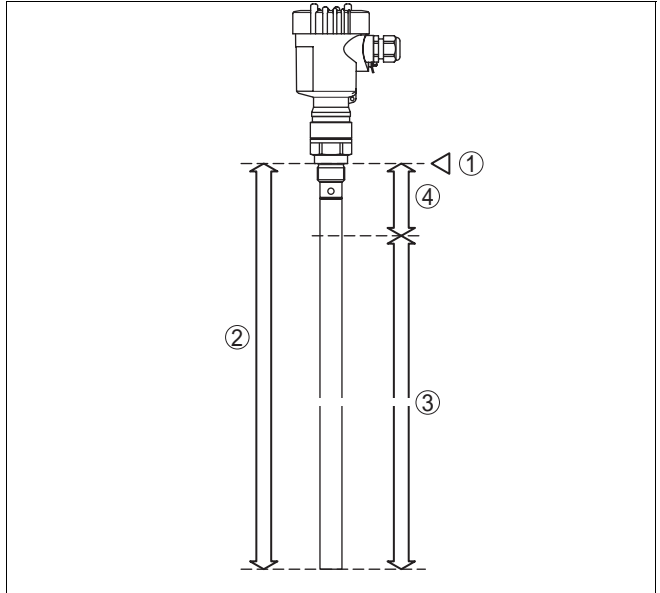

Fig. 4: Dead zones

- 1 Reference plane
- 2 Probe length
- 3 Measuring range
- 4 Upper dead zone

Pressure/Vacuum

In case of gauge or low pressure in the vessel, you have to seal the mounting boss on the thread. Check before use, if the seal material is resistant against the measured product.

4.2 Mounting procedure

Installation position

Mount VEGAFLEX 65 in such a way that the probe does not touch any vessel installations or the vessel wall during operation.

In vessels with a conical bottom it can be advantageous to

mount the sensor in the center of the vessel, as measurement is then possible down to the lowest point of the vessel bottom.

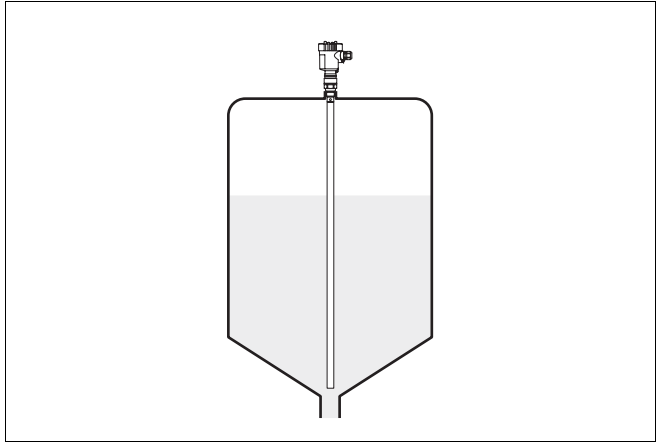

Fig. 5: Vessel with conical bottom

Inflowing material

Make sure that the probe is not subjected to strong lateral forces. Mount VEGAFLEX 65 at a location where no disturbing influences caused by, e.g. stirrers, filling openings, etc. can occur.

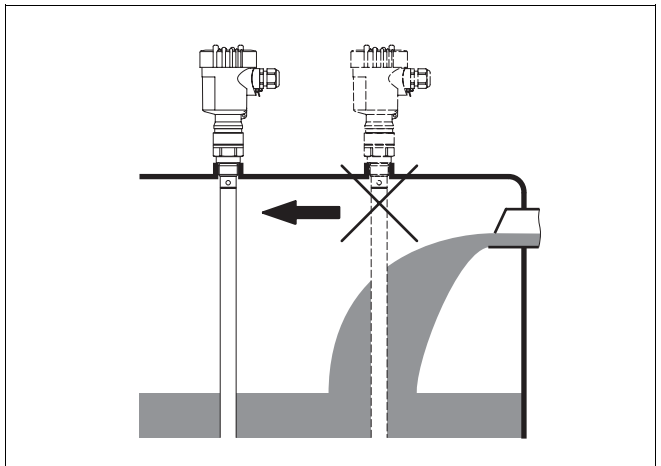

Fig. 6: Lateral load

5 Connecting to power supply

5.1 Preparing the connection

Note safety instructions

Always observe the following safety instructions:

- Connect only in the complete absence of line voltage
- If overvoltages are expected, overvoltage arresters should be installed.



Tip:

We recommend VEGA overvoltage arresters ÜS-F-LB-I and ÜSB 62-36G.X.

Take note of safety instructions for Ex applications



In hazardous areas you should take note of the appropriate regulations, conformity and type approval certificates of the sensors and power supply units.

Select power supply

Power supply and current output are carried on separate two-wire connection cables. The power supply range can differ depending on the instrument version. The exact range is stated in the Technical data in the Supplement.

With the standard version, the current output can be operated ground-based, with the Exd version it must be operated floating.

This instrument is designed in protection class I. To maintain this protection class, it is absolutely necessary that the ground conductor is connected to the inner ground conductor terminal. Take note of the general installation regulations.

Connect VEGAFLEX 65 generally to vessel ground (potential equalisation) or in case of plastic vessels to the next ground potential. A ground terminal is provided laterally on the instrument housing.

Select connection cable

An approved installation cable with PE conductor is necessary for power supply.

The 4 ... 20 mA current output is connected with standard two-wire cable. A cable outer diameter of 5 ... 9 mm ensures the seal effect of the cable entry. If electromagnetic interference is expected, we recommend the use of screened cable.

Screening and grounding

Connect cable screen on both ends to ground potential. In the sensor, the screen must be connected directly to the inner ground terminal. The ground terminal outside on the housing must be connected to potential equalisation.

If potential equalisation currents are expected, the connection must be provided on the processing side via a ceramic capacitor (e.g. 1 nF, 1500 V). The low frequency potential equalisation currents are thus suppressed, the protective effect of the high frequency interference signals, however, remains.

Select connection cable for Ex applications



Take note of the corresponding installation regulations for Ex applications.

5.2 Connection procedure

Proceed as follows:

- 1 Unscrew the housing cover
- 2 Loosen compression nut of the cable entry
- 3 Remove approx. 10 cm of the cable mantle (current output), strip approx. 1 cm insulation from the ends of the individual wires
- 4 Insert cable into the sensor through the cable entry
- 5 Lift the opening levers of the terminals with a screwdriver
- 6 Insert the wire ends into the open terminals according to the wiring plan
- 7 Press down the opening levers of the terminals, you will hear the terminal spring closing
- 8 Check the hold of the wires in the terminals by lightly pulling on them

- 9 Connect the screen to the internal ground terminal and the external ground terminal to potential equalisation
 - 10 Tighten the compression nut of the cable entry, the seal ring must completely encircle the cable
 - 11 Connect the connection cable for power supply in the same way acc. to the wiring plan, in addition connect the protective conductor to the internal ground terminal
 - 12 Screw the housing cover back on
- The electrical connection is finished.



Fig. 7: Connection steps 5 and 6

5.3 Wiring plans, double chamber housing



The following illustrations apply to the non-Ex as well as to the Exd version.

Housing overview

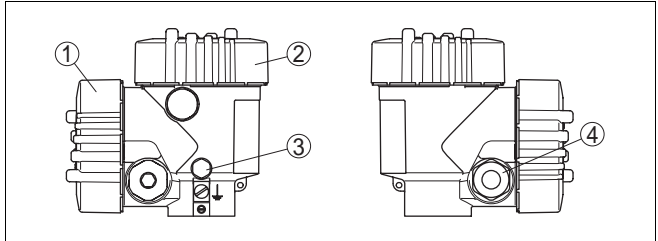

Fig. 8: Double chamber housing

- 1 Connection compartment
- 2 Electronics compartment
- 3 Filter element for pressure compensation
- 4 Cable entry or plug

Electronics compartment

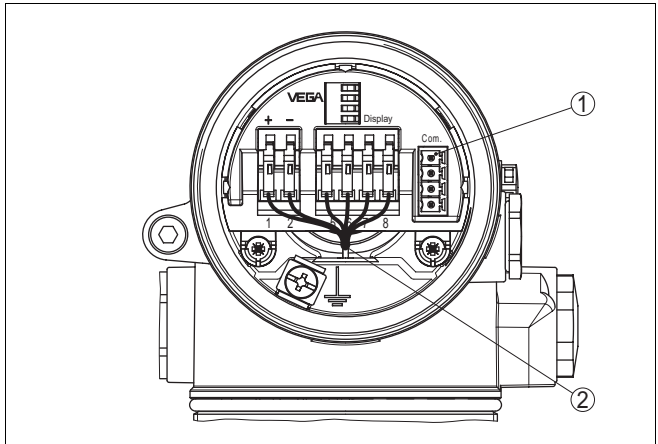

Fig. 9: Electronics compartment, double chamber housing

- 1 Plug connector for VEGACONNECT (I²C interface)
- 2 Internal connection cable to the connection compartment

Connection compartment

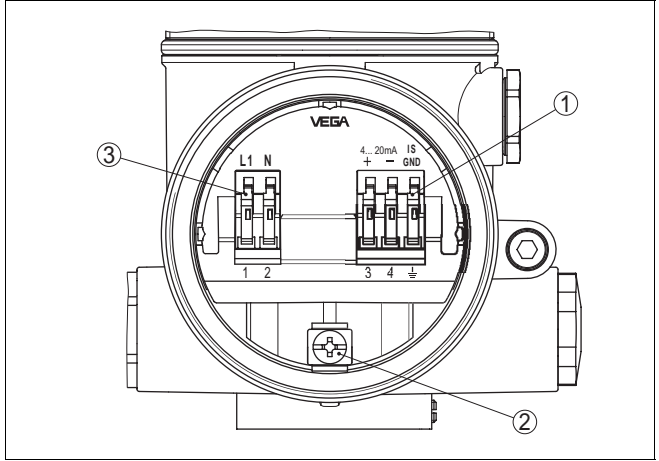

Fig. 10: Connection compartment, double chamber housing

- 1 Spring-loaded terminals for the signal output
- 2 Ground terminal for connection of the protective conductor and the screen
- 3 Spring-loaded terminals for power supply

Wiring plan

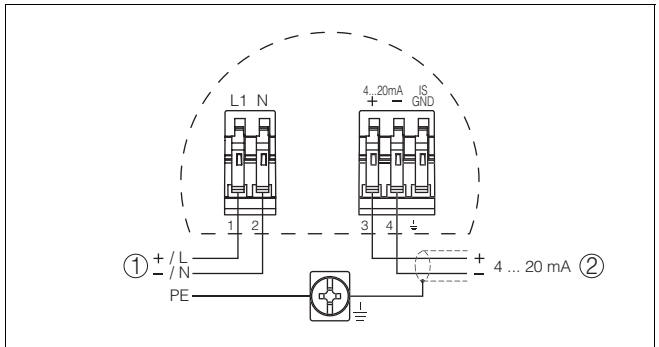

Fig. 11: Wiring plan, double chamber housing

- 1 Power supply
- 2 Signal output

6 Set-up with the indicating and adjustment module PLICSCOM

6.1 Short description

Function/Configuration

The indicating and adjustment module PLICSCOM is used for measured value display, adjustment and diagnosis. It can be mounted in the following housing versions and instruments:

- all sensors of the plics® instrument family, in the single as well as in the double chamber housing (optionally in electronics or connection compartment)
- external indicating instrument VEGADIS 61

6.2 Installing the indicating and adjustment module PLICSCOM

Insert/remove PLICSCOM

PLICSCOM can be inserted or removed at any time. An interruption of the power supply is not necessary.

To install, proceed as follows:

- 1 Unscrew housing cover
- 2 Place PLICSCOM in the desired position on the electronics (you can choose any one of four different positions - each displaced by 90°)
- 3 Press PLICSCOM lightly onto the electronics and turn it to the right until it snaps in
- 4 Screw housing cover with inspection window tightly back on

Removal is carried out in reverse order.

PLICSCOM is powered by the sensor, an additional connection is not necessary.



Fig. 12: Installation of PLICSCOM



Note:

If you intend to retrofit VEGAFLEX 65 with PLICSCOM for continuous measured value indication, a higher cover with an inspection glass is required.

6.3 Adjustment system

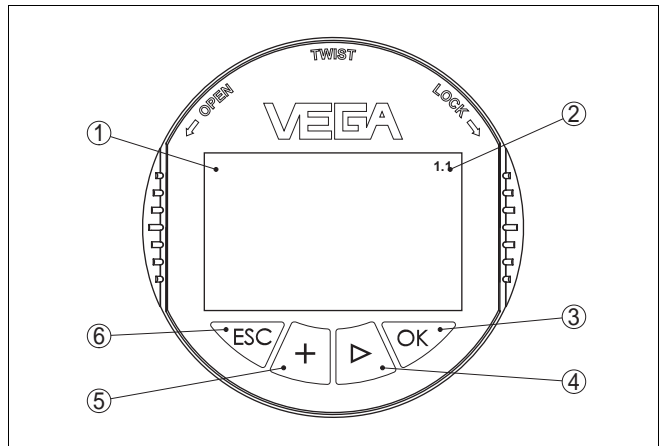

Fig. 13: Indicating and adjustment elements

- 1 **LC display for indication of:**
 - measured value
 - menu item
 - parameter
- 2 **Indication of the menu item number**
- 3 **OK key:**
 - move to the menu overview
 - confirm selected menu
 - edit parameter
 - save value
- 4 **-> key to select:**
 - menu change
 - list entry
 - editing position
- 5 **+ key:**
 - modify value of a parameter
- 6 **ESC key:**
 - interrupt input
 - jump to the next higher menu

Adjustment system

The sensor is adjusted via the four keys of the indicating and adjustment module PLICSCOM. The LC display indicates the individual menu items. The functions of the individual keys are shown in the above illustration. Approx. 10 minutes after the last pressing of a key, an automatic reset to measured value display is triggered. Any values not confirmed with **[OK]** will not be saved.

6.4 Set-up procedure

Switching on phase

After VEGAFLEX 65 is connected to power supply, the instrument carries out a self-test for approx. one minute. The following steps are carried out:

- internal check of the electronics
- indication of the instrument type, the firmware version as well as the sensor tag (sensor name)
- the output signal jumps briefly to the set fault current

Then the actual measured value is displayed and the corresponding current is transmitted to the cable. ¹⁾

Address setting HART-Multidrop

In HART-Multidrop mode (several sensors on one input) the address must be set before continuing with the parameter adjustment. You will find a detailed description in the operating instructions manual of PLICSCOM.

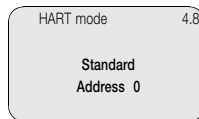

Parameter adjustment

Since VEGAFLEX 65 is a distance measuring instrument, it measures the distance from the sensor to the product surface. In order to have the actual level displayed, an allocation of the measured distance to the percentage height must be carried out. To make this adjustment, the full and empty distances in the vessel are entered. If these values are not known, it is also possible to carry out the adjustment with other distances, e.g. 10 % and 90 %. Starting point for these distance values is always the seal surface of the thread or flange. The actual level is then calculated on the basis of these entered values. At the same time, the operating range of the sensor is limited from maximum range to the requested range.

¹⁾ The values correspond to the actual level as well as to the settings already carried out, e.g. default setting.

The real product level during this adjustment is not important, because the min./max. adjustment is always carried out without changing the product level. These settings can be made ahead of time without the instrument having to be installed.

In the main menu item "Basic adjustment", the individual submenu items should be selected one after the other provided with the correct parameter values. This will ensure optimum adjustment of the measurement.

Start your parameter adjustment with the following menu items of the basic adjustment:

Carrying out min. adjustment

Proceed as follows:

- 1 Move from the measured value display to the main menu by pushing **[OK]**.

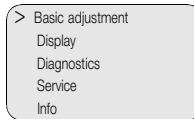

- 2 Select the menu item *Basic adjustment* with **[->]** and confirm with **[OK]**. Now the menu item "Min. adjustment" is displayed.

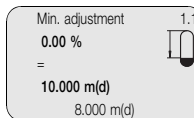

- 3 Prepare the percentage value for editing with **[OK]** and set the cursor to the requested position with **[->]**. Set the requested % value with **[+]** and save with **[OK]**. The cursor jumps now to the distance value.
- 4 Enter the appropriate distance value in m (corresponding to the percentage value) for the empty vessel (e.g. distance from the sensor to the vessel bottom).
- 5 Save the settings with **[OK]** and move to the max. adjustment with **[->]**.

Carrying out max. adjustment

Proceed as follows:

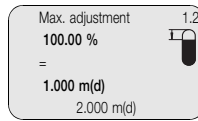

- 1 Prepare the percentage value for editing with **[OK]** and set the cursor to the requested position with **[->]**. Set the requested % value with **[+]** and save with **[OK]**. The cursor jumps now to the distance value.
- 2 Enter the appropriate distance value in m (corresponding to the percentage value) for the full vessel. Make sure that the max. level must be beneath the dead zone.
- 3 Save the settings with **[OK]**.

Damping

To suppress fluctuation in the measured value display, e.g. by agitated product surfaces, an integration time can be set. This time can be between 0 and 999 seconds. Please note that the reaction time of the entire measurement will be longer and the sensor will react to quick changes of the measured value with a corresponding delay. In general, a time of a few seconds is sufficient to smooth the measured value display.

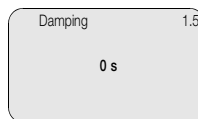

Enter the requested parameters via the appropriate keys, save your settings and jump to the next menu item with **[->]**.

Linearization curve

A linearisation is necessary for all vessels in which the vessel volume does not increase linearly with the level, e.g. in a cylindrical or spherical tank and the indication or output of the volume is requested. Corresponding linearisation curves are preprogrammed for these vessels. They represent the correlation between the level percentage and vessel volume. By activating the appropriate

curve, the volume percentage of the vessel is displayed correctly. If the volume should not be displayed in percent, but e.g. in l or kg, it is possible to set a scaling in the menu item "Display".

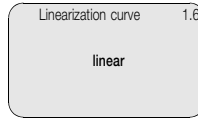

Enter the requested parameters via the appropriate keys, save your settings and jump to the next menu item with the **[→]** key.

Sensor-TAG

In this menu item you can enter an unambiguous designation for the sensor, e.g. the measurement loop name or the tank or product designation. In digital systems and in the documentation of larger plants, a unique designation should be entered for exact identification of individual measuring sites.

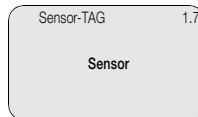

After completing this menu item the basic adjustment is finished and you can now return to the main menu with the **[ESC]** key.

Optional settings

Additional adjustment and diagnosis options such as e.g. scaling, simulation or echo or trend curve presentation are shown in the following menu schematic. You will find a detailed description of these menu items in the operating instructions manual of the indicating and adjustment module PLICSCOM.

6.5 Menu schematic

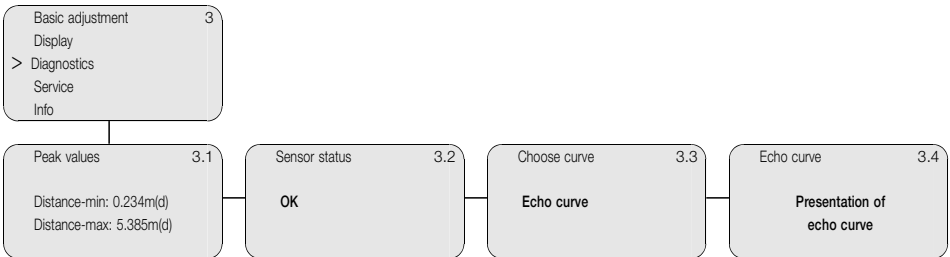
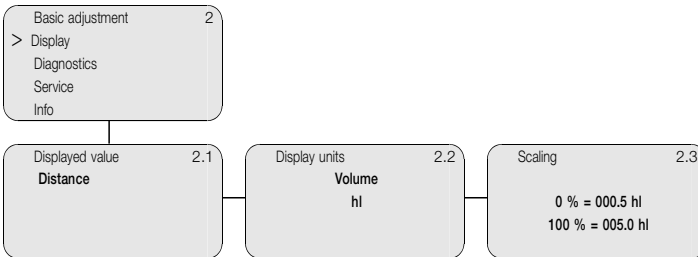
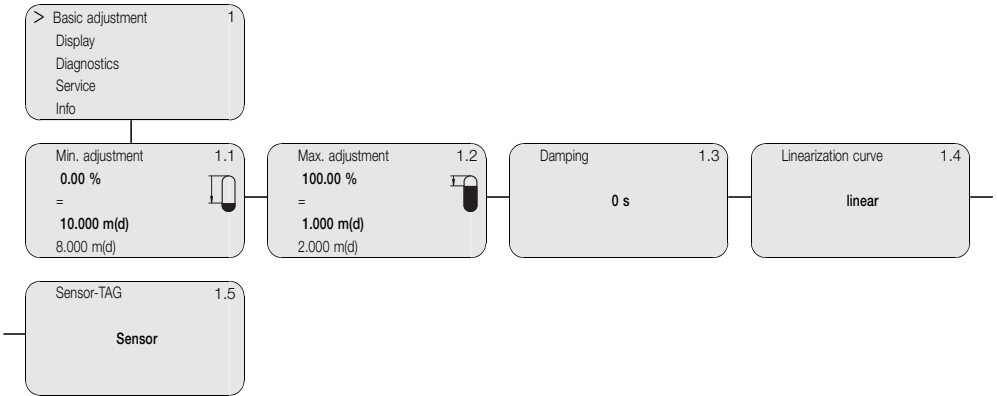

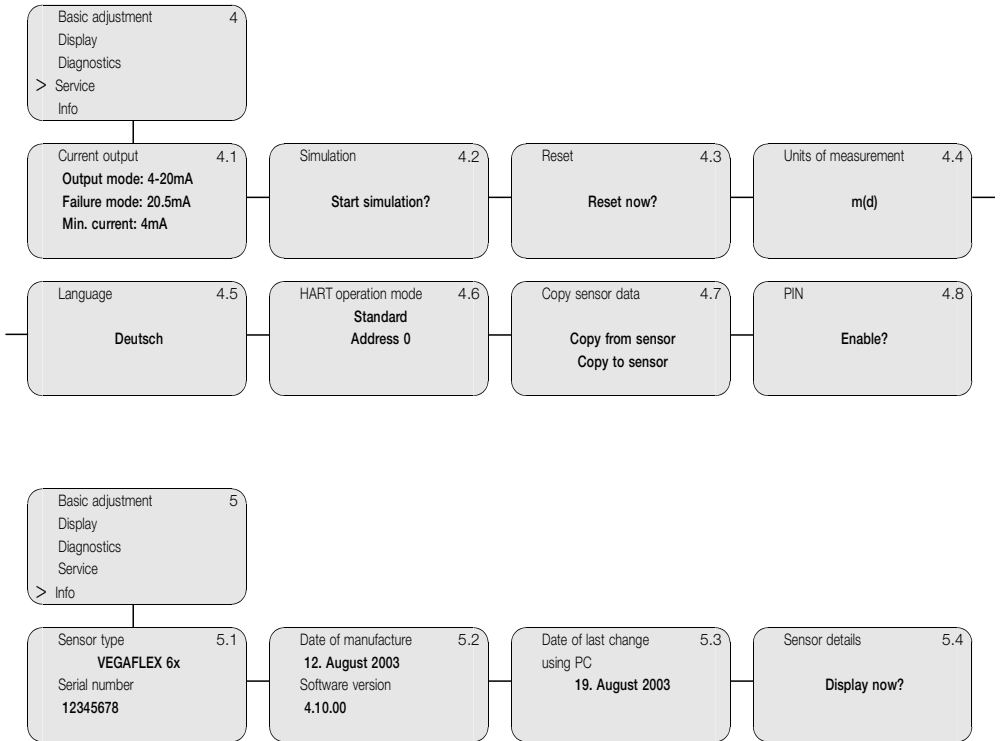

7 Set-up with PACTware™

7.1 Connecting the PC

Connecting the PC directly to the sensor

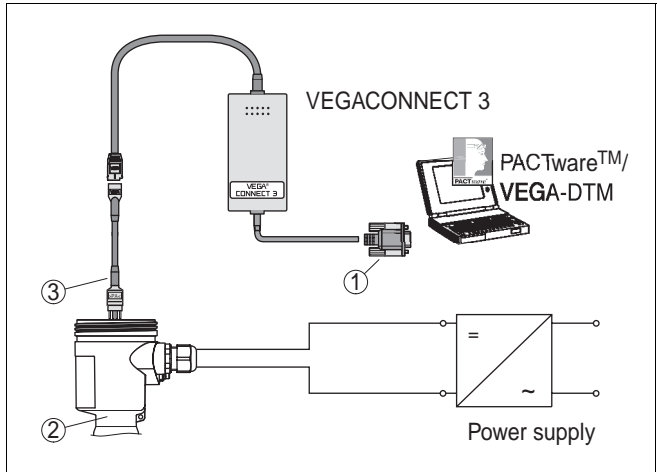

Fig. 14: PC connected directly to the sensor

- 1 RS232 connection
- 2 VEGAFLEX 65
- 3 I²C adapter cable for VEGACONNECT 3

Necessary components:

- VEGAFLEX 65
- PC with PACTware™ and suitable VEGA-DTM
- VEGACONNECT 3 with I²C adapter cable (article no. 2.27323)
- power supply unit

Connecting the PC to the signal cable

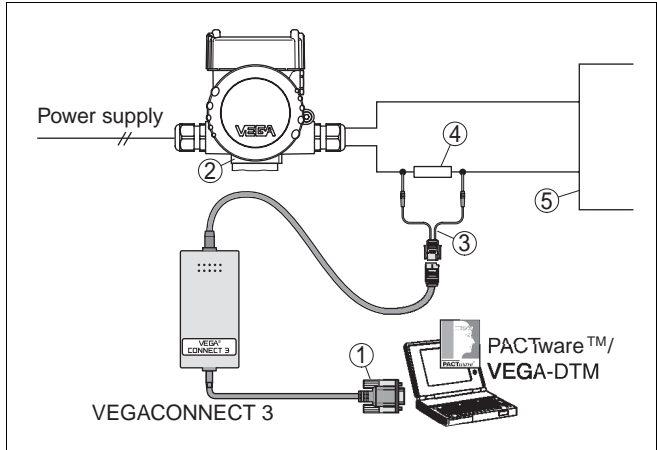

Fig. 15: PC connected to the signal cable

- 1 RS232 connection
- 2 VEGAFLEX 65
- 3 HART adapter cable for VEGACONNECT 3
- 4 HART resistance 250 Ohm
- 5 4 ... 20 mA processing

Necessary components:

- VEGAFLEX 65
- PC with PACTware™ and suitable VEGA-DTM
- VEGACONNECT 3 with HART adapter cable
- HART resistance 250 Ohm
- power supply
- 4 ... 20 mA processing



Note:

With processings with integrated HART resistance (internal resistance approx. 250 Ohm), an additional external resistance is not necessary. In such cases, VEGACONNECT 3 can be connected in parallel to the 4 ... 20 mA cable.

7.2 Parameter adjustment with PACTware™

Further set-up steps are described in the operating instructions manual *DTM Collection/PACTware* attached to each CD and which can be downloaded from our homepage. A detailed description is available in the online help of PACTware™ and the VEGA-DTMs.

**Note:**

Keep in mind that for set-up of VEGAFLEX 65 DTM-Collection 11/2002 or a newer version should be applied.

All actually available VEGA DTMs are provided in the DTM-Collection on CD and are available from the respective VEGA agency against a token fee. This CD includes also the up-to-date PACTware™ version. The basic version of this DTM-Collection incl. PACTware™ is also available as a free of charge download from the Internet.

8 Maintenance and fault rectification

8.1 Maintenance

When used in an appropriate manner in normal operation, VEGAFLEX 65 is completely maintenance-free.

8.2 Fault rectification

Checking the 4 ... 20 mA signal

Connect a hand-multimeter with the suitable measuring range acc. to the wiring plan.

? 4 ... 20 mA signal not stable

- level fluctuations
- set integration time via PLICSCOM or PACTware™

? 4 ... 20 mA signal missing

- incorrect connection to power supply
- check connection acc. to chapter "Connection procedure" and correct if necessary acc. to chapter "Wiring plans"
- no power supply
- check cables on line break, repair if necessary
- power supply too low or load resistance too high
- check and adapt, if necessary

? Current signal greater than 22 mA or 0 mA

- electronics module defective
- exchange instrument or return it for repair



Fault messages via PLICSCOM

In Ex applications, the regulations for the wiring of intrinsically safe circuits must be observed.

? E013

- no measured value available
- sensor in boot phase
- sensor does not find an echo, e.g. through incorrect installation or parameter adjustment

? E017

- adjustment span too small
- carry out a fresh adjustment, increase the distance between min. and max. adjustment

? E036

- no operable sensor software
- carry out software update or return instrument for repair

? E042/E043

- hardware error, electronics defective
- exchange instrument or return it for repair

8.3 Repairing the instrument

If it is necessary to repair VEGAFLEX 65, please send the instrument to the following address:

VEGA Grieshaber KG; Repair department; Am Hohenstein 113; 77761 Schiltach/Germany

9 Dismounting

9.1 Dismounting procedure

Take note of chapters "Mounting" and "Connecting to power supply" and carry out the listed steps in reverse order.

9.2 Disposal

VEGAFLEX 65 consists of materials which can be recycled by specialised recycling companies. We have purposely designed the electronic modules to be easily separable. Mark the instrument as scrap and dispose of it according to government regulations (electronic scrap ordinance, etc. ...).

Materials: see Technical data

If you cannot dispose of the instrument properly, please contact us about disposal methods or return.

10 Supplement

10.1 Technical data

General data

Materials, wetted parts

- process fitting 1.4435 (316L) and PCTFE; Hastelloy C22 2.4602 and PCTFE
- seal Viton, Kalrez 6375 and EPDM
- tube \varnothing 21.3 mm 1.4435 (316L)/Hastelloy C22 2.4602

Materials, non-wetted parts

- housing plastic PBT (Polyester), Alu-die casting powder-coated, stainless steel 1.4435
- seal ring between housing and housing cover NBR (stainless steel housing), silicone (Alu/plastic housing)
- inspection window in housing cover for PLICSCOM Polycarbonate
- ground terminal stainless steel 1.4571/1.4435

Weights

- plastic housing 760 g
- Aluminium housing 1170 g
- Aluminium double chamber housing 1470 g
- stainless steel housing 1530 g
- tube (\varnothing 21.3 mm) approx. 1000 g/m

Lengths (L)

- tube (\varnothing 21.3 mm) 0.5 ... 4 m
 - lateral load - tube \varnothing 21.3 mm 60 Nm
-

Output variable

Output signal	4 ... 20 mA/HART
Resolution	1.6 μ A
Fault signal	current output unchanged, 20.5 mA, 22 mA, < 3.6 mA (adjustable)
Current limitation	22 mA
Load	
– 4-wire sensor	max. 500 Ohm ²⁾
– 2-wire sensor	see load diagram in Power supply
Integration time (63% of the input variable)	0 ... 999 s, adjustable
Rise time	150 ms (ti : 0 s, 0 ... 100 %)
Fulfilled Namur recommendation	NE 43

Input variable

Parameter	level of liquids
Min. dielectric figure	Er >1.4
Dead zone with tube- \emptyset 21.3 mm	
– top	150 mm

²⁾ with inductive load, ohmic share at least 25 Ohm/mH

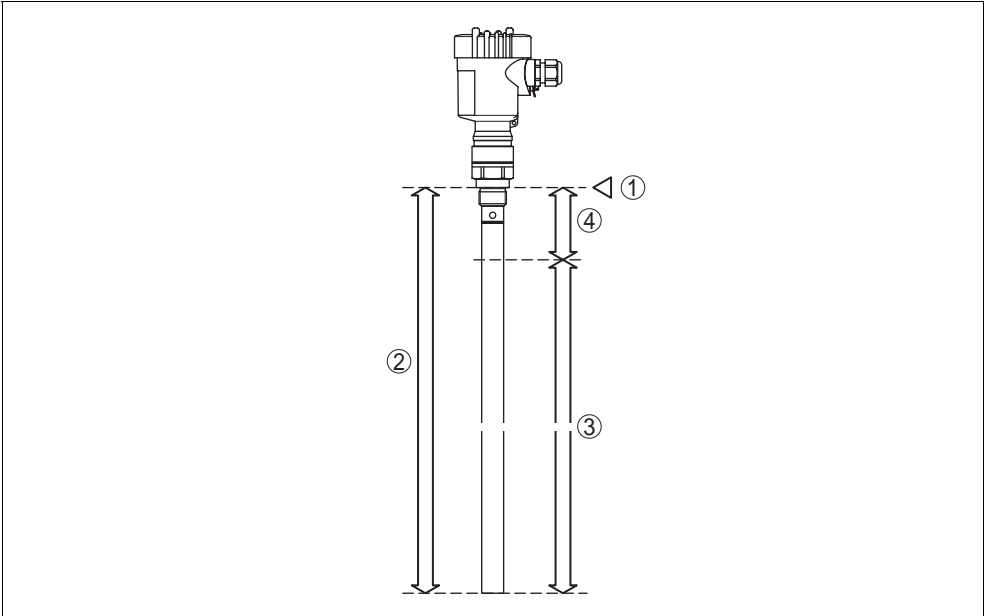

Fig. 16: Measuring ranges of VEGAFLEX 65

- 1 Reference plane
- 2 Probe length
- 3 Measuring range
- 4 Upper dead zone

Accuracy (similar to DIN V 19259-1 and IEC 60770-1)

Reference conditions acc. to IEC60770-1

- temperature 18 ... 30°C
- relative humidity 45 ... 75 %
- pressure 860 ... 1060 mbar (86 ... 106 kPa)

Determination of characteristics limit point adjustment acc. to DIN 16086

Characteristics linear

Characteristics curve deviation and measurement characteristics

Reference installation conditions

- flange DN 100
- min. distance to installations 1 m

Reference reflector metal plate \varnothing 1m

Temperature drift 0.015 %/10 K relating to the max. measuring range

Accuracy see diagram

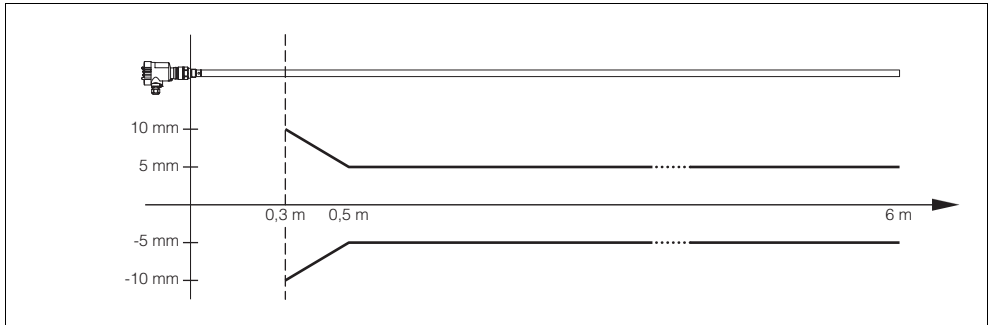

Fig. 17: Accuracy VEGAFLEX 65

Ambient conditions

Ambient, storage and transport temperature

- without PLICSCOM -40 ... +80°C
- with PLICSCOM -40 ... +70°C

Process conditions

Process pressure -1 ... 40 bar (-100 ... 4000 kPa) at PN 40

Process temperature (thread or flange temperature)

- Viton -30 ... 150°C
- EPDM -40 ... 150°C
- Kalrez 6375 -20 ... 150°C

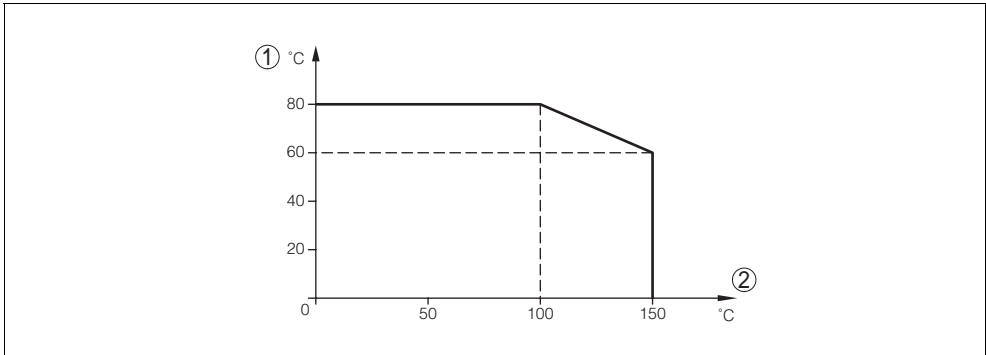

Fig. 18: Ambient temperature - Product temperature

- 1 Ambient temperature
2 Product temperature

Electromechanical data

Cable entry/plug (depending on the version)

- single chamber housing
 - 1 x cable entry M20x1.5 (cable- \varnothing 5 ... 9 mm), 1 x blind stopper M20x1.5
 - or:
 - 1 x closing cap $\frac{1}{2}$ NPT, 1 x blind stopper $\frac{1}{2}$ NPT
 - or:
 - 1 x plug M12x1, 1 x blind stopper M20x1.5
- double chamber housing
 - 1 x cable entry M20x1.5 (cable- \varnothing 5 ... 9 mm), 1 x blind stopper M20x1.5
 - or:
 - 1 x closing cap $\frac{1}{2}$ NPT, 1 x blind stopper $\frac{1}{2}$ NPT
 - or:
 - 1 x plug M12x1, 1 x blind stopper M20x1.5

Spring-loaded terminals

for wire cross sections up to 2.5 mm²

Indicating and adjustment module PLICSCOM

Power supply and data transmission	through sensor via gold-plated sliding contacts (I ² C bus)
Display	LC display in full dot matrix
Adjustment elements	4 keys
Protection	IP 20 (mounted into sensor without cover: IP 40)
Materials	
– housing	ABS
– inspection window	Polyester foil

Power supply

Power supply	
– non-Ex and Ex d instrument	20 ... 72 V DC, 20 ... 253 V AC, 50/60 Hz
Power consumption	max. 4 VA, 2.1 W

Electrical protective measures

Protection	IP 66/IP 67
Overvoltage category	III
Protection class	I

Approvals ³⁾

ATEX II 1G, 1/2G, 2G EEx ia IIC T6,
ATEX II 1/2G, 2G EEx d ia IIC T6, ATEX II
1/2D IP66 T, WHG, ship approvals

³⁾ Deviating data with Ex applications: see separate safety instructions

10.2 Dimensions

VEGAFLEX 65 - threaded version

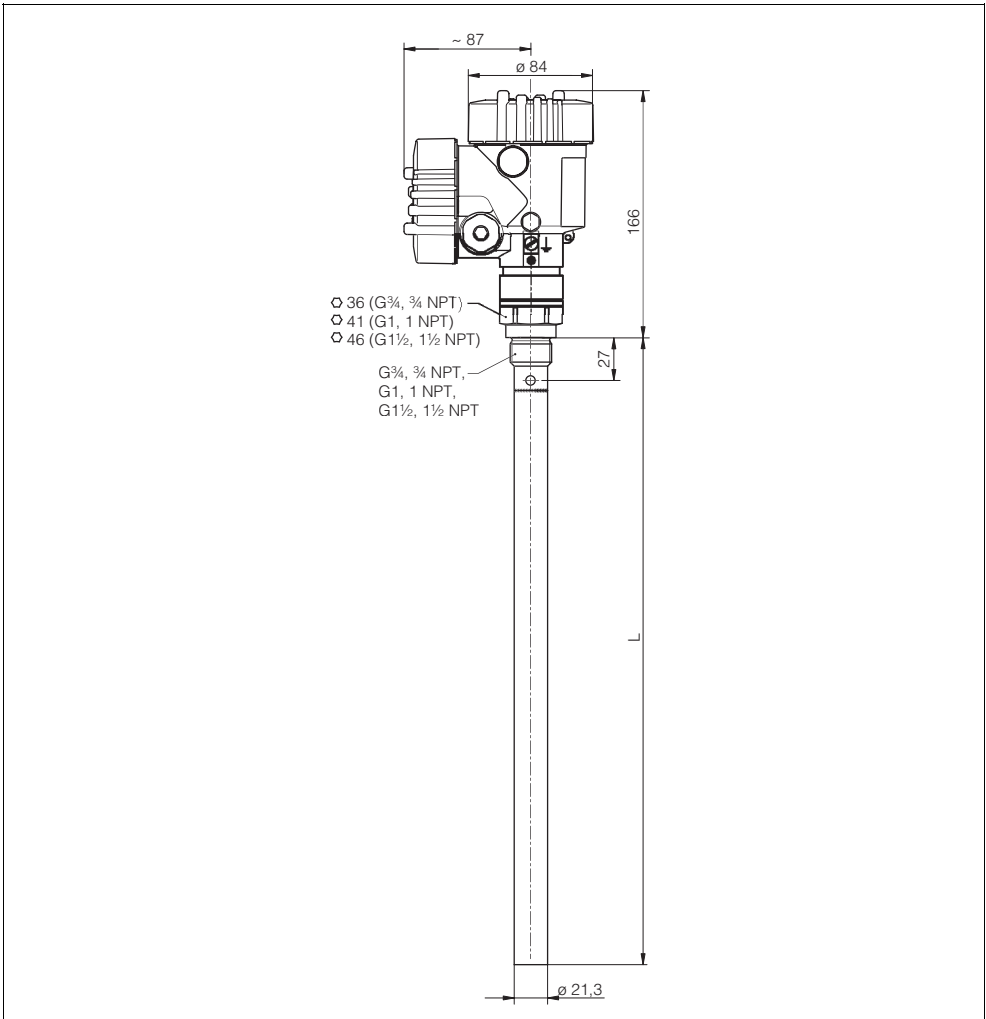

Fig. 19: VEGAFLEX 65

L = sensor length, see Technical data

VEGAFLEX 65 - flange version

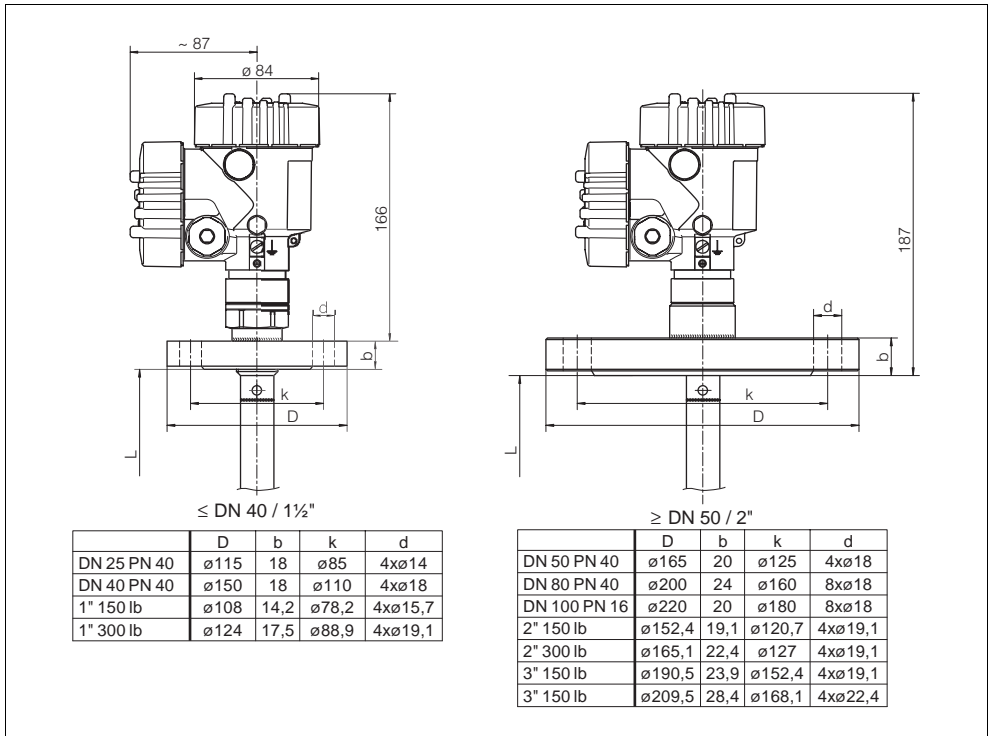

Fig. 20: VEGAFLEX 65- flange version
L = sensor length, see Technical data

